

Taal: Engels



Handleiding

CAV

CA Eco 55i

Frequentiegeregelde cycloon 5,5 kW

MSH equipment

Appelmarkt 7

1681 PE Zwaagdijk-Oost

Tel: 0228-561100

Fax: 0228-561112

Mail: info@msh-equipment.nl

Website: www.msh-equipment.nl



Original User's Manual

Installation - Use - Maintenance

Original instructions translation. For any possible doubt, please refer to instructions of the Original Manual in Italian

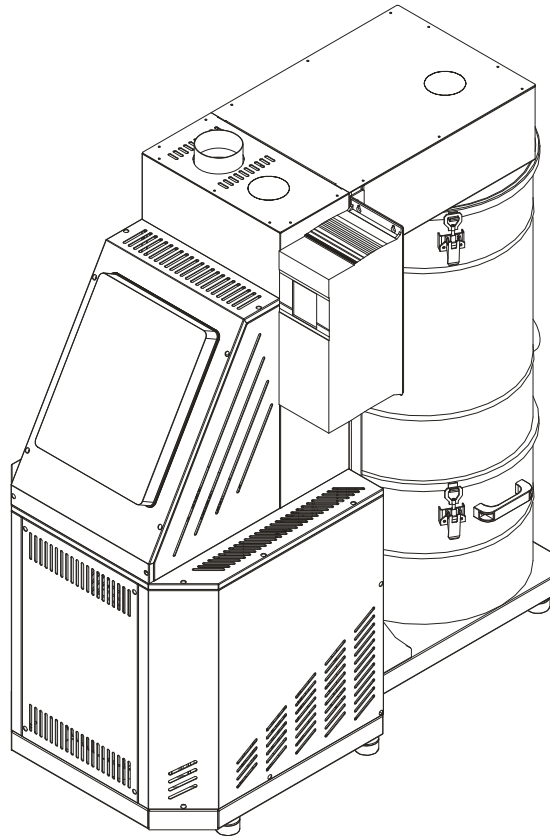

TURBINE EXHAUSTER

Eco 55i



Eco 55i Manual	03-2012
Document	Revision





CONTENTS

1 GENERAL INFORMATION	3	5 OPERATION	14
1.1 MANUFACTURER	3	5.1 PERSONNEL	14
1.2 POINTS OF SALE AND SERVICE CENTRES	3	5.2 CONTROL PANEL	14
1.3 CERTIFICATION	3	5.3 COMMISSIONING AND USE	14
1.4 WARRANTY	3	5.4 OPERATING MODES	15
1.5 CUSTOMER'S OBLIGATIONS	3	5.5 JOB END	15
1.6 MANUAL LAYOUT	4	5.6 DECOMMISSIONING	15
1.6.1 PURPOSE AND CONTENTS	4		
1.6.2 MANUAL ADDRESSEES	4	6 MAINTENANCE	15
1.6.3 MANUAL STORAGE	4	6.1 MACHINE CUT-OFF	15
1.6.4 SYMBOLS	4	6.2 SPECIAL PRECAUTIONS	15
		6.3 PARTS SUBJECT TO MAINTENANCE	16-17
2 MACHINE DESCRIPTION (MACHINE)	5	6.4 CLEANING	18
2.1 PRINCIPLE OF OPERATION	5	6.5 ROUTINE MAINTENANCE	18
2.2 MAIN COMPONENTS	5	6.6 EXTRAORDINARY MAINTENANCE	18
2.3 MACHINE STRUCTURE	5		
2.4 DIMENSIONS	5	7 DIAGNOSTICS	19
2.5 AMBIENT CONDITIONS	5	7.1 TROUBLESHOOTING	19
2.6 LIGHTING	5	7.2 AFTER-SALES SERVICE	20
2.7 VIBRATIONS	5		
2.8 NOISE EMISSIONS	5	8 SPARE PARTS	20
2.9 SPECIFICATIONS	6	8.1 SPARE PARTS LIST	20
2.10 OUTFIT	6	8.2 ORDERING SPARE PARTS	21
2.10.1 STANDARD	6		
2.10.2 OPTION EQUIPMENT ON REQUEST	6	9 SCRAPPING	21
2.11 ELECTROMAGNETIC ENVIRONMENT	6	9.1 DISPOSING OF WASTE	21
		9.2 MACHINE SCRAPPING	21
3 SAFETY RULES	7		
3.1 GENERAL WARNINGS	7	10 ANNEXES	21
3.2 INTENDED USE	7	10.1 DECLARATIONS	28
3.3 UNSUITABLE USE	7	10.2 DIAGRAMS	22-27
3.4 DANGEROUS AREAS	7	10.3 WARRANTY FORM	29
3.5 SAFETY DEVICES	7	10.4 MAINTENANCE LOG BOOK	30-31
3.6 STOP CONTROLS	8		
3.7 SAFE WORKING PROCEDURES	8	Annex: Inverter instruction manual	
3.8 RESIDUAL RISKS	8		
3.9 NAMEPLATES	8		
4 INSTALLATION	9		
4.1 TRANSPORT AND HANDLING	9		
4.2 STORAGE	9		
4.3 ARRANGEMENTS BEFORE INSTALLATION	9		
4.4 ASSEMBLY	10		
4.5 SET-UP	10		
4.6 CONNECTIONS	11		
4.6.1 PNEUMATIC CONNECTIONS	11		
4.6.2 ELECTRIC CONNECTIONS	12		
4.6.3 SUCTION	13		
4.6.3a OUTLET	13		
4.7 PRELIMINARY INSPECTION	13		
4.8 ADJUSTMENTS AND CHECKS	13		



1 GENERAL INFORMATION

1.1 MANUFACTURER

CAV S.r.l. has been manufacturing Service control units for industrial use for more than thirty years; this experience has led to a considerable technological Know-how based on many years of R&D activities carried out in tight connection with the product manufacturing and trading on the international market, and this is the best quality guarantee that CAV can offer to users.

1.2 POINTS OF SALE AND SERVICE CENTRES

CAV directly offers after-sales service for its products sold in Italy or in Europe.
(Sales, After-sales, Spare parts)

CAV S.r.l.,
Via Morandi, 90 - Toscanella di Dozza (Bologna), Italy
Postal Code 40060
Phone +39 (0)542 673488
E-mail: sales@cavitaly.com

Customers are kindly requested to contact the above-indicated central After-sales Service for any doubt or clarification about use, maintenance or request for spare parts. Please remember to specify the Machine identification details that can be found on the nameplates:

See Nameplate A, paragraph 3.9

1.3 CERTIFICATION

The Machine complies with the prevailing European Union Directives applicable at the moment of its release on the market, as detailed in the declaration of conformity.

1.4 WARRANTY

Machine components are covered by a 12-month (twelve month) warranty: this period starts from the date indicated on the purchase document (invoice). **Warranty does not cover electrical and electronic parts.**

Warranty only covers faulty parts, no labour costs and service call fee.

Warranty excludes any Exhauster damage due to:

- transport and/or handling;
- wrong or improper use of the Machine;
- failed compliance with maintenance specifications given in this Manual; (see paragraph 6.5)
- failures and/or faults not ascribable to faulty parts.

1.5 CUSTOMER'S OBLIGATIONS

The Customer shall, within the time frame agreed upon with the Manufacturer, fulfil its obligations indicated in the Documents attached to the sales contract. Unless otherwise agreed, the Customer normally shall take care of:

- Preparing the rooms, including any required building works and/or channels.
- Air supply with compressed air (see paragraph 4.6.1).
- Machine power supply, complying with the prevailing rules in the Country of use (see paragraph 4.6.2).



1.6 MANUAL LAYOUT

The Customer is required to carefully read this manual since correct pre-setting, installation and use of the Machine are basic requirements for its trouble-free and safe operation.

1.6.1 PURPOSE AND CONTENTS

This manual shall give all necessary information for correct and safe use of the product. It deals with technical information, operation and maintenance details, as well as instructions for spare parts and safety warnings. Before attempting any operation on the Machine, Operators and Qualified Technicians are required to carefully read the instructions given herein.

Manual content derives from an ongoing and methodical job of data processing and technical tests filed and approved by C.A.V., complying with the internal safety procedures and data quality rules.

Data herein indicated are **EXCLUSIVELY** for specialised personnel, that could interface with the product under safety conditions for any person, the machine and the environment, carry out a simple troubleshooting and understand strange/faulty operating conditions, carry out simple inspections and maintenance, still fully complying with the instructions given in the following pages and prevailing health and safety regulations.

All details about installation, assembly, removal, extraordinary maintenance, repair and installation procedures for any accessories, devices and equipment, are mentioned and can only be performed by specialised personnel or by the **AUTHORISED AFTER-SALES SERVICE**, fully complying with the manufacturer's recommendations and the prevailing health and safety rules.

It is important to keep this manual in a known place and ensure it is legible, for possible future reference. In case of damage or for further technical and operation details, please contact directly our **AUTHORISED AFTER-SALES SERVICE**.





1.6.2 MANUAL ADDRESSEES

This Manual addresses both the Operator and the Technicians allowed to carry out maintenance operations on the machine. Operators shall not carry out any operation reserved to Maintainers or Qualified Technicians. Failure to do so, the Manufacturer will not be liable for any resulting damage.

1.6.3 MANUAL STORAGE

This Manual shall be kept next to the Machine and in such a position protected from any fluid or any other condition that could compromise its readability.

1.6.4 SYMBOLS

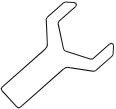
	DANGER	Indicates a hazard resulting in a (serious) risk for user or any other person.
	WARNING	Pay utmost attention to the paragraphs highlighted by this symbol.
	DANGER OF ELECTROCUTION	Indicates a hazard of electrocution resulting in a (serious) risk for user or any other person.
	SPECIALISED PERSONNEL	Specialised personnel is required for special operations.
	SEE MANUAL	It is necessary to refer to the User's Manual before attempting a certain operation.
	ADJUST	Mechanical adjustment and/or electric set-up could be necessary.



2 MACHINE DESCRIPTION

2.1 PRINCIPLE OF OPERATION

This C.A.V. exhauster is made of a load bearing frame on which mechanical, electromechanical, electronic and pneumatic devices or units are installed and are used, altogether or combined with one another, for suction and filtering of the dust resulting from dry sanding primer or filler/surfacer.

The machine description specifies the intended use for which the product was designed, produced and protected. Any different use or failure to comply with the following specifications could create danger for persons and/or property.

The model described herein consists of some main and auxiliary units, whose functions are listed here below and are aimed at carrying out a production cycle under safety conditions.

Please exclusively contact directly the AUTHORISED AFTER-SALES SERVICE for further details or specifications.

2.2 MAIN COMPONENTS

The machine consists of the following main components:

1. Operator panel
2. Filter holder cylinder
3. Dust collector cylinder
4. Motor guard
5. Bedplate

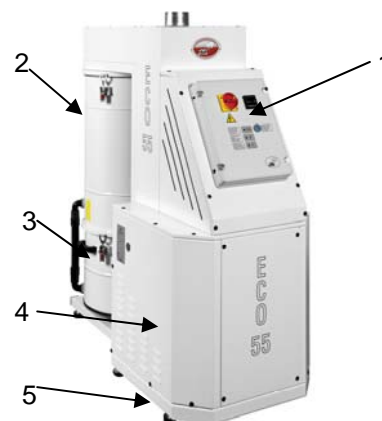

2.3 EXHAUSTER STRUCTURE

Unit bedplate and main parts are made of a stiff metal structure. Removable filtering unit includes dust collection bin. Exhauster is completely enclosed by a front metal guard. A control panel with controls for operation and adjustment is installed in the main electric panel. Power supply connections are realised by means of power and control cables.

2.4 DIMENSIONS

Overall dimensions are specified under paragraph 2.9 -Specifications.

2.5 AMBIENT CONDITIONS

The Exhauster does not require any special ambient conditions. Nevertheless, it shall be installed in a well-lit industrial building, featuring suitable minimum guaranteed air change.

Ambient temperature for correct unit operation shall be in the range +5°C to +40° C.

2.6 LIGHTING

Room lighting shall comply with the prevailing rules in the country where the machine is installed. In the area where the Exhauster is installed, good visibility shall be ensured for easier routine and extraordinary maintenance. Minimum recommended illumination: 400 lux.

2.7 VIBRATIONS

If unit is used according to the instructions for correct use, vibrations shall not create any dangerous situation.

2.8 NOISE EMISSIONS

The Exhauster is designed and manufactured to limit noise emissions at the source.

Maximum noise level is 75dB. Actual noise emission shall in any case be measured after installation, in order to ensure that it still conforms to the specifications required by the prevailing laws.



2.9 SPECIFICATIONS

This section indicates Machine technical features and specifications user shall refer to in case of contact with the Manufacturer After-sales Service.

TABLE 2. 9A - Technical Features and Specifications

Description	Features
Power supply	400V-415V-50Hz
Installed power	5,5 kW
Compressed air supply	Max. 10 Bar
Relative humidity	Max. 90% w/out condensate
Weight (kg)	250
Dimensions	1280x615x h1380 mm
Nominal power input	13.3 A

2.10 OUTFIT

The following equipment refers to the standard production Exhausters. Any special machine could hence require parts different than the listed ones.

2.10.1 STANDARD

The Exhauster comes with:

- User's Manual
- Declaration of conformity
- Installation equipment

2.10.2 OPTION EQUIPMENT ON REQUEST

No options are set with respect to the standard outfit.

Any change and/or addition of any accessory whatsoever must be explicitly approved and made by the Manufacturer.

2.11 ELECTROMAGNETIC ENVIRONMENT

The Exhauster is designed to operate correctly within an electromagnetic or industrial environment. Design conforms to the principles of the product Harmonised Technical Standards:

HARMONISED EUROPEAN STANDARD

EN 60439-1(third edition)

February (1995) ref. CENELEC EN 60439-1:1994-01

HARMONISED EUROPEAN STANDARD

EN 60439-1/AI/Ali September (1997) ref. CENELEC EN 60439-1/AI:1995-12+ EN 60439-1/AI1:1996-02

In particular, manufacturer used proven components and principles, as required by 7.10 of EN 60439-1/AI:1995-12+ EN 60439-1/AI1:1996-02

Built-in electronic equipment was installed as indicated in the instructions that come with the equipment itself and considering the general criteria for **EMC** specified in **EN 60204-1 art. 4.**

HARMONISED EUROPEAN STANDARD EN 60439-1(third edition)

February (1995) ref. CENELEC EN 60439-1:1994-01

HARMONISED EUROPEAN STANDARD EN 60439-1/AI/Ali

September (1997) ref. CENELEC EN 60439-1/AI:1995-12+ EN 60439-1/AI1:1996-02

In particular, manufacturer used proven components and principles, as required by 7.10 of EN 60439-1/AI:1995-12+ EN 60439-1/AI1:1996-02

Built-in electronic equipment was installed as indicated in the instructions that come with the equipment itself and considering the general criteria for **EMC** specified in **EN 60204-1 art. 4.**



3 SAFETY RULES

3.1 GENERAL WARNINGS

The Operator shall carefully read the information given in this Manual, especially the Safety rules and precautions specified in this section.

Moreover, it is fundamental that the Operator follows these warnings:

- Keep the Exhauster and the work area clean and in order;
- Use the Exhauster in normal psychophysical conditions;
- Wear appropriate clothes and personal protection gear suitable for products in use;
- Do not remove or tamper with the Manufacturer nameplates on Exhauster;
- Do not remove or make inoperative any of the Exhauster Safety systems.
- **Do not use this unit in rooms subjected to risk of explosion.**

3.2 INTENDED USE

The Exhauster is designed for removing non-explosive dust in general or similar material.

3.3 UNSUITABLE USE

Do not use the Exhauster:

- for different purposes than those indicated in 3.2;
- to take in substances that could result in a flammable and/or explosive environment;
- in environments featuring explosive, aggressive atmosphere or with high dust or oily content;
- in environments with a serious fire hazard;
- outdoors, exposed to any weather condition;
- to take in red-hot parts and/or parts on fire;
- in a different way than stated in safety installation rules given herein.

3.4 DANGEROUS AREAS

Although the Exhauster does not involve any particular danger for exposed persons, it shall be used taking some precautions, considering that:

- The operator can come into contact with dangerous chemical products by accident and without being aware of the resulting danger.
- Before use, the person in charge of production shall evaluate unit use conditions according to the danger possibly caused by products and take suitable protections such as: work in a room featuring a guaranteed minimum ventilation or change of air.
- **Pay utmost attention when removing the dust bag. Carefully follow the filter removal procedure described in the manual and shown in the figures on the package.**
- Exhaust tube and silencer could reach a very high temperature (>55°C) so it is important that users wear any necessary safety gear before starting any operation.

3.5 SAFETY DEVICES

The Exhauster comes complete with suitable guards to protect the persons exposed to risks due to moving organs, risks connected to power supply, and so on.

The unit fits the following safety devices:

- Metal barrier all around the mobile parts. Basically, the enclosures are a barrier for any potentially dangerous parts.
- The emergency stop is performed via the control panel main switch.
- Rotating pushbutton cuts off machine supplies to perform maintenance under safety conditions.
- Safety release on the levers for removing the dust collector cylinder metal body.

The User is requested to install the following safety devices:

- **Electrical equipment with TT system:** emergency knife switch, with differential protection of the B type for pulsating current and power input of 15 A, against direct and indirect contacts on Exhauster power control panel (if activated, it causes uncontrolled stop of all actuators and power cut-off).
- **Electrical equipment with TN or IT system:** refer to control panel specifications to install the suitable protections.



3.6 STOP CONTROLS

The Exhauster stop controls are:

- Main power cut-out by Main Switch (to set unit out of service, located on control panel installed by the Customer);
- Rotating knife switch incorporated in **power control panel** that, when activated, cuts power to both auxiliary and power circuits;
- Controlled stop due to opening of the run enable auxiliary contact (e.g. suction mouthpiece Open / Closed).

3.7 SAFE WORKING PROCEDURES

The Exhauster design features aim at eliminating all risks connected to its use.

The residual risks involved in operating mode are:

- Risks connected with the use of pneumatic energy;
- Risks connected with the use of electric energy;
- Risks of possible contact with product removed by suction;
- Risks of possible contact with hot surfaces.

To limit the consequences of such dangers as much as possible, it is important to comply with the following rules:

- Ensure that air supply pressure is available and set to specified value: **max. 10 bars**;
- Do not start the Exhauster before checking the correct installation and parameters set at operator panel; this can be done by running a cycle with no product to be taken in by exhauster;
- Wear the personal protection gear suitable for the product in use;
- Wear clothes with close-fitting sleeves.

3.6 STOP CONTROLS

The Exhauster stop controls are:



- Main power cut-out by Main Switch (to set unit out of service, located on control panel installed by the Customer);
- Rotating knife switch incorporated in **power control panel** that, when activated, cuts power to both auxiliary and power circuits;
- Controlled stop due to opening of the run enable auxiliary contact (e.g. suction mouthpiece Open / Closed).

3.7 SAFE WORKING PROCEDURES

The Exhauster design features aim at eliminating all risks connected to its use.

The residual risks involved in operating mode are:

Nameplate "A"

 Via R. Morandi, 93 - 40060 TO SCANELLA BOLOGNA ITALY Tel. 0542-673488 Fax: 0542-672065	
MOD.	
KW	
A	MASSA Kg
VOLTS	
Hz	
M ³ /h	
Mbar	
MATRICOLA N.	
MESE ANNO COSTRUZIONE	200
	

Nameplate "B"

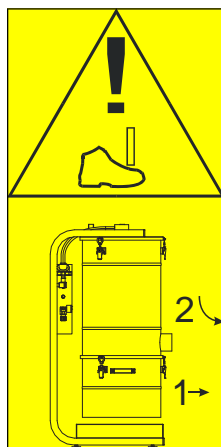

Nameplate "C"

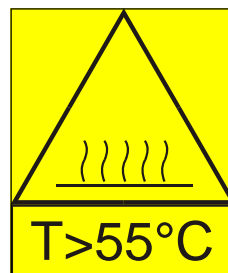

Nameplate "D"

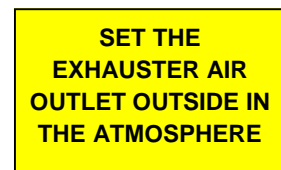

Nameplate "E"

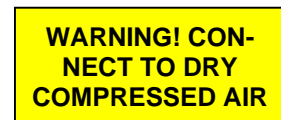

Nameplate "G"



Nameplate "F"

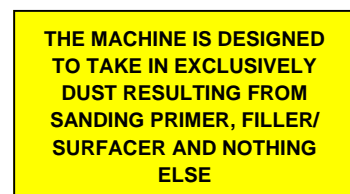



Figure 3. 9 B - Nameplates position



	WARNING! THE SAFETY WARNING NAMEPLATES SHALL NOT BE REMOVED, COVERED OR DAMAGED.
---	--

4 INSTALLATION

4.1 TRANSPORT AND HANDLING

Have unit transported by qualified and trained Personnel. The Exhauster shall be handled in a suitable way so as to avoid damages. All protections, electric circuits, control equipment, shall be suitably closed and fastened.

The Exhauster is packed on pallet, wrapped in plastic and covered with cardboard. Packed machine dimensions and weight are indicated on the package. Check for transport damages together with the carrier.

N.B.: The Manufacturer will not be liable for damages due to improper lifting and handling of the packed unit.

	WARRANTY does not cover any damage to the Exhauster due to transport and handling. Any repair or replacement of damaged parts is at the Customer's charge.
---	---

4.2 STORAGE

For any long period of inactivity, store the Exhauster in a suitable place, considering storage environment and time. In particular, consider allowed ambient temperature range, humidity and pollution.

- Store the Exhauster indoors;
- Protect the Exhauster from any shock and stress;
- Protect the Exhauster from humidity and extremely wide temperature ranges +0° C + 60 °C;
- Avoid contact with corrosive substances.

4.3 ARRANGEMENTS BEFORE INSTALLATION

Before installation, it is necessary to prepare a suitable operating area, limiting any interference with other activities as much as possible.



4.4 ASSEMBLY

Exhauster can be assembled either by the Technicians authorised by the manufacturer or directly by the customer, following these steps:

Unpacking.

Remove all packing material from the machine, using suitable tools and setting it in a suitable place. Dispose of the packing material according to the prevailing environment protection regulations.

(Visually) **check** machine external parts for damage, carefully ensure that there are no scratches, denting or damaged parts.

Report any fault, failure or missing parts found within five days from machine arrival. Beyond this term the Manufacturer is no longer liable for the machine supplied.

WARNINGS AND PRECAUTIONS for installation

Always start by checking correct operation, assembly and efficiency of controls and safety systems. **In case** you find operating faults, immediately stop the machine and contact the AUTHORISED AFTER-SALES SERVICE. **Pay attention** to the adhesive nameplates on the machine. Should they become damaged or illegible, promptly change them. For this operation contact the AUTHORISED AFTER-SALES SERVICE or the Manufacturer. Have **any maintenance intervention** -as per the definition of "user" given in the foreword section- performed by qualified personnel. **Using spare parts** that do not comply with the following specifications, any change or tampering (though small as they may be) relieve the Manufacturer of any liability concerning the correct use, operation and safety of persons and/or property. **It is strictly forbidden** to tamper with equipment, control organs and safety devices. **Dispose of waste** as required by the prevailing laws. **If the machine is used by many operators**, all of them shall read the instructions for use and indicate any maintenance intervention or parts replaced, or just suspected faults on the servicing data sheet.

4.5 SET-UP

Set Exhauster and filtering unit on a flat and clean surface and ensure that the equipment and tools for machine mechanical set-up are in place.

To handle the machine under safety conditions, lift it by means of a fork lift truck. After setting the machine in position, level it and tighten the lock nuts to ensure it stays firmly in place.

N.B.: It shall always be possible to work all around the machine for maintenance purposes. Ensure there is enough room in this area upon installation.

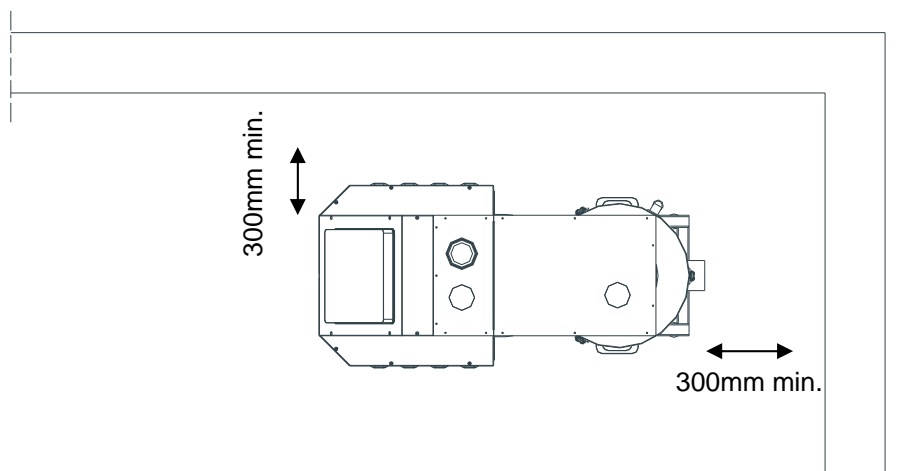

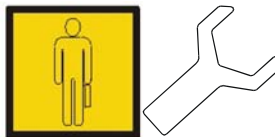

4.6 CONNECTIONS

To avoid any problem upon Exhauster start-up, follow the instructions below.

4.6.1 PNEUMATIC CONNECTIONS

Figure 4. 6. 1A- Pneumatic System Layout

Connection to the air supply is ensured by a flexible hose secured with screw clamps.

The mobile connection is supplied together with the Exhauster.

The standard Exhauster comes with regulator unit.

Air supply requirements:

- Operating pressure: 5 bars
- Maximum pressure: 10 bars

Connect compressed air supply to the connection, by inserting a gate valve (to be supplied by Customer) on the pre-set line so that the supply can be cut off during maintenance. It is strongly recommended to feed the machine with dry compressed air.

Compressed air of the supply line must be completely dry, i.e. treated upstream of the exhauster. It is recommended to install a 5 micron air filter.





4.6.2 ELECTRIC CONNECTIONS

Figure 4. 6. 3A- Electric System Layout

POWER SUPPLY

Exhauster electrical connections are at the Customer's charge, under its own responsibility. The electrical connections of the Exhauster shall consider:

- the Laws and Technical Standards applicable at the time of installation in the place of installation;
- data indicated on " Nameplate A ".

Make the electrical connections.

Supply power to the machine with a suitable cross-section, also providing suitable protections for direct and indirect contact. **This line and the relevant protections are at the Customer's charge.**

- Power cord is with double insulation and of suitable cross-section (approx. 3m long) and completed with ground wire.
- Feedback shielded cable for connection of the vacuum sensor, completed with suitable connector (approx. 50m).
- Control cable or for remote starting shall have a section of 2x1.5 sq.mm (approx. 3m long) and shall be connected to electric item microswitch line.

The electrical system design and components ensure utmost dependability and safety of use. The attached wiring diagrams will allow identification of all connections and components. Only make the required electrical connections; do not modify any circuits, calibrations, components, etc. Failure to follow this warning will be considered as tampering. Before connecting to the mains, ensure that power voltage and frequency correspond to the specifications indicated on the nameplate. **Perform ground connections and/or zero setting as required by the prevailing laws of the country.**

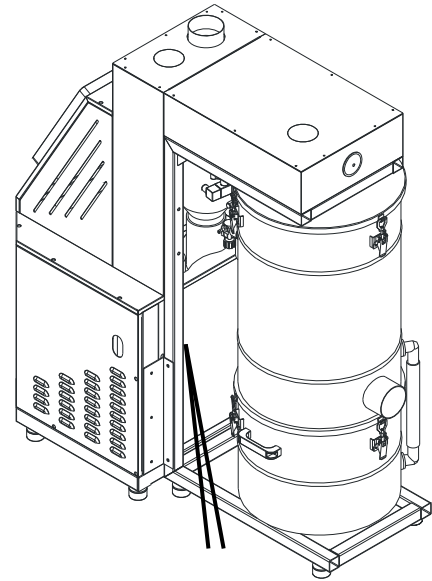



4.6.3 SUCTION

Connect the Ø100mm fitting located on filter holder cylinder to an antistatic flexible hose deriving from the main suction line. “Peel” the copper wire and fold it inward (if tube is grounded) or connect it to a ground or bonding lead. Fasten the hose with its metal clamp.

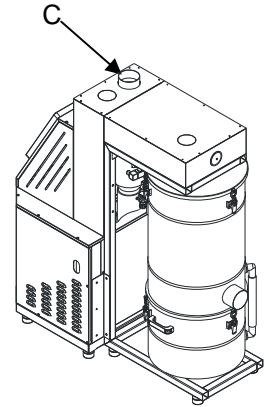

4.6.3a OUTLET

Set outlet lines having a minimum diameter of 100mm. It is necessary to install, in-between silencer (C) and outlet line, a rubber hose to allow for silencer removal and maintenance. **Important: The outlet lines weight must not lie on silencer.**

4.7 PRELIMINARY INSPECTION

Power supply, compressed air supply and Exhauster preparation stages for commissioning do not require any special knowledge apart from those acquired after reading this manual. Before commissioning the Machine it is necessary to perform some inspections and checks in order to avoid errors or accidents:

- Ensure that the Exhauster did not suffer any damage during assembly;
- Pay special attention when checking electrical parts, control panels, cables and air lines;
- Check that all external supplies connections are correct;
- Ensure that all mobile parts can move freely.

4.8 ADJUSTMENTS AND CHECKS

The Exhauster is tested at the Manufacturer's premises, before shipment. No further adjustment is necessary.

When starting the Exhauster for the first time, proceed as follows:

- Set the QSI Main switch lever to ON (**switch is installed by the Customer**);
- Open compressed air supply cock; ensure that compressed air regulator reads 5 bars;
- After being supplied, the Exhauster sets to automatic operation mode. Only by voluntarily activating the control “I” can the machine be set to stand-by mode, ready to start when the remote starter contact is closed.



5 OPERATION

5.1 PERSONNEL

The Exhauster is designed for use by many Operators.

Personnel allowed to work on the Exhauster shall have the following knowledge (or acquire it after suitable training) and be familiar with the contents of this Manual as well as all Safety-related concerns:

- General and technical knowledge of suitable level to understand Manual contents;
- Knowledge of the main health and safety and accident prevention rules;
- Knowledge of how to behave in an emergency situation, where to find personal protection gear and how to use it correctly.

Maintainers, apart from the above, shall also have suitable electrical, pneumatic and mechanical Technical knowledge.

5.2 CONTROL PANEL

Exhauster controls are on the control panel, at Machine front.

Figure 5.2 a - controls on front panel

KEY:

1. Control panel main switch;
2. Hour counter;
3. Filter cleaning warning light and button;
4. Power on warning light;
5. Inverter and reset alarm warning light;
6. Start pre-setting button;
7. Stop button

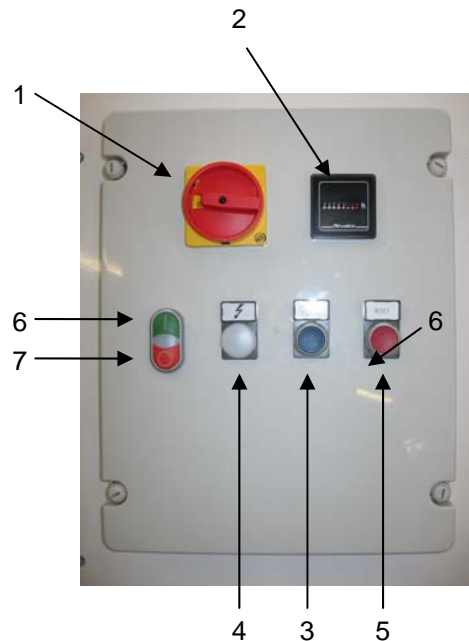

5.3 COMMISSIONING AND USE

To power on the Exhauster proceed as follows:

1. Set the Main Switch to ON;
2. Press button " I " to set the machine to Stand-By mode;
3. Open compressed air supply cock
4. When one of the suction mouthpieces opens, so that the remote contact closes, the machine starts and performs set function, as pre-programmed at the Factory with default settings, that are usually suitable for normal use. If generated vacuum is not suitable to the production needs, user can change parameter P3.5 and vary it. Changes made to this parameter are proportional to vacuum variation that can be obtained. When value increases, even the machine power consumption increases while the machine range for use decreases. When the suction mouthpiece closes, the machine progressively slows down and then stops.



5.4 OPERATING MODES

After commissioning you can use the machine, no operator intervention is necessary.

5.5 JOB END

The procedure for a voluntary stop is as follows:

1. Open the main switch on QSI electric panel installed by the customer (OFF position);
2. Open the main switch on machine control panel;
3. Close compressed air supply cock.

5.6 DECOMMISSIONING

In case of long periods of inactivity or **in case of maintenance, user shall compulsorily:**

- Open and padlock the QSI main switch on main control panel (see Figure 6.1 A);
- Close and lock compressed air inlet valve (see Figure 6.1.B);
- Release circuit air by opening the condensate drain cock;
- Put out a panel reading "EXHAUSTER BEING SERVICED".

6 MAINTENANCE

6.1 EXHAUSTER CUT-OFF

Before attempting any maintenance or repair job, user must cut all Exhauster supplies, proceeding as follows:

1. Open and padlock the main switch on main control panel (6.1A).
2. Close and padlock the compressed air supply and open the condensate drain cock to drain the system (6.1B).

6.1A

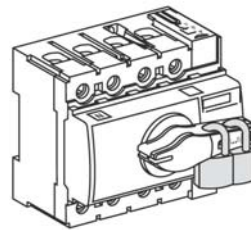

6.1B

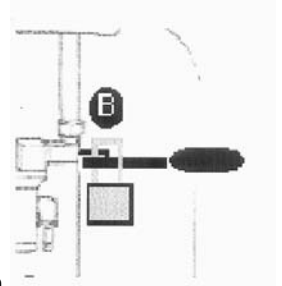

6.2 SPECIAL PRECAUTIONS

When carrying out maintenance or repair jobs, it is recommended to proceed as follows:

- Before starting, put out a panel reading "EXHAUSTER BEING SERVICED" in a visible position.
- **Wait at least 10 minutes before gaining access to inverter or motor: this will allow the dissipation of the energy stored inside the inverter;**
- Do not use solvents and flammable materials;
- Do not release lubricants into the environment;
- Machine parts are not designed to bear a Person's weight; do not stand on them or they could break.
- When job is completed, restore and correctly fasten all protections and guards previously removed or opened, as well as any safety device, if previously disabled.



6.3 PARTS SUBJECT TO ROUTINE MAINTENANCE

Maintenance shall be carried out with the Exhauster set out of service for replacement of damaged or worn parts. The Exhauster does not require frequent maintenance. If compressed air does not meet indicated requirements, the following could get damaged:

1. Pressure regulator
2. Solenoid valve
3. Filter cartridge
4. Dedusting device

Should filter cartridge fail and break, this could damage the turbine unit (5) and the silencer (6).

1) Remove the regulator:

- Close air feed;
- Discharge any residual air;
- Reset (zero) the regulator by working the knob anticlockwise until it stops.
- Remove the adjuster knob by pulling it;
- Open the regulator by loosening the knob tang.
- Clean or change the membrane and reassemble all parts following the same procedure, in reverse order.
- Restore 5 bar pressure.

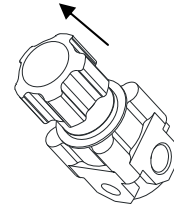

2) Replace solenoid valve if it jams. Change as follows:

- Close air feed;
- Release any residual air by opening the condensate drain cock;
- Remove the connector by undoing the retaining screw;
- Remove the connecting tube and loosen the solenoid valve;
- Clean and/or change the solenoid valve;
- Connect the connector and reconnect the tubes.





3) Filter cartridge

- **Cut off power supply and compressed air** (see relevant procedures in the previous pages);
- Disconnect Ø100 inlet hose from inlet manifold;
- Remove the dust collector cylinder;
- Remove the filter holder cylinder;
- Loosen nut under filter cartridge;
- Set the new filter cartridge in place, ensuring to set it at the centre and that the seal correctly sets against the plate;
- Tighten the nut, do not squeeze seal too much (nut finger tight + two turns);
- Refit the filter holder cylinder;
- Refit the dust collector cylinder;
- Refit the vacuum connection line between cylinders.
- Reconnect the Ø100 hose.

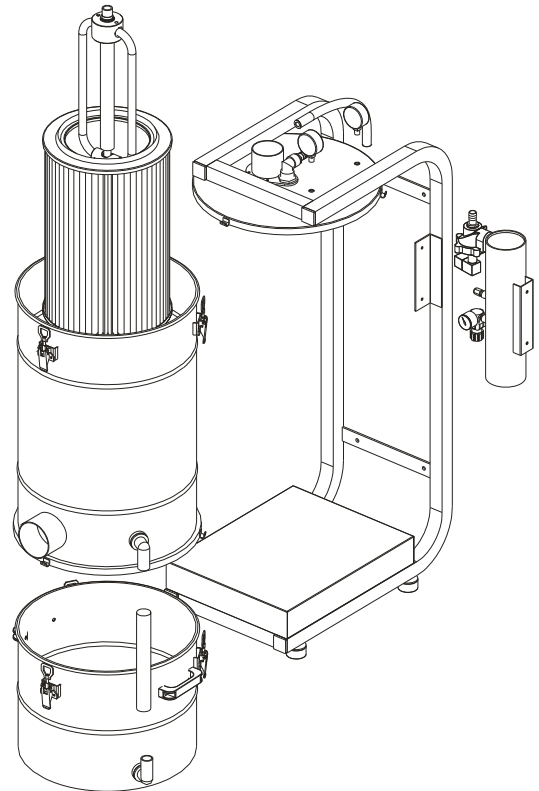

4) Dedusting device

- Cut off power supply and compressed air (see relevant procedures in the previous pages);
- Proceed as described in step 3 until removing the filtering cartridge;
- Loosen the dedusting device and replace it with a new one;
- Reassemble as indicated in step 3.

5) Motor

- **Cut off power supply** and compressed air (see relevant procedures in the previous pages);
- Contact Authorised After-sales Service.

6) Silencer

- **Cut off power supply** and compressed air (see relevant procedures in the previous pages);
- Remove the silencer unit, **ensuring no foreign objects can fall inside the turbine outlet tube**;
- Blow compressed air at 6 bars inside the silencer;
- Reassemble the silencer unit.



6.4 CLEANING

It is recommended to frequently clean the whole Machine (intervals depend on type and frequency of use). Use a soft rag. Do not use water and/or solvents.

- **Monthly** clean inside the machine to ensure motor cooling efficiency.
- **Changing the bag.** It is impossible to set a standard interval for replacing the dust collector bag so it is important to frequently check dust quantity during the first two weeks of use. Periodically empty the bag according to the work you do. Release the three levers to unlock the dust collector cylinder. Disconnect the vacuum tube and remove the cylinder by pulling the two side handles. Pull out the nylon bag and close it. Fit a new bag, ensure it adheres to cylinder walls. Turn over bag exceeding length on cylinder edge. Refit the dust collector cylinder and engage the three levers. **Important!** Refit and ensure that the vacuum tube does not leak. Any leak (though small as it may be) will move the nylon bag up toward the filter cartridge, thus blocking off the machine suction opening, and finally break the bag. It is necessary to dispose of the collected dust according to the prevailing laws of the country where machine is installed.



6.5 ROUTINE MAINTENANCE

The following operations shall be performed at the indicated time intervals. Failure to comply with this schedule will relieve the Manufacturer of any liability or Warranty obligation.

These operations, though simple as they may be, shall be carried out by **suitably trained and expert Personnel.**

Scheduled routine maintenance includes inspections, tests and interventions aiming at preventing system stoppage due to faults or potentially dangerous situations.

6.6 EXTRAORDINARY MAINTENANCE

Extraordinary maintenance is an activity reserved to personnel appointed by the manufacturer or the manufacturer itself. Please contact the centres specified under paragraph 1.2 in case of need. **Considering the machine routine maintenance, the intervention of a technician for extraordinary maintenance is highly unlikely, unless for special cases or when expressly requested.**

MAINTENANCE	DESCRIPTION	INTERVENTION
Pneumatic System	Valves and tubes/lines	No scheduled maintenance required.
Pneumatic System	Condensate drain	Weekly
Electrical System	Control Panel	No scheduled maintenance required.
Suction System	Filter	Change every 2000 hours or when the load loss is more than 70/80 mm H ₂ O.
Turbine Motor	Bearings. Have bearings changed by an Authorised Service Centre.	Change every 15,000 hours.
Motor compartment	Clean carefully.	Monthly.
Dust collector bags	Change.	When necessary.
Tighten power wiring screws	Tighten screws and junctions PLACE UNIT OUT OF SERVICE BEFORE PERFORMING THIS OPERATION	Perform 3 months after installation and repeat every six months.



7 DIAGNOSTICS

7.1 TROUBLESHOOTING

Table 7.1 A

TROUBLE	CAUSE	INSPECTION AND/OR FIX
Dust is coming out of the silencer.	<ul style="list-style-type: none"> Faulty filter cartridge Worn seal 	<ul style="list-style-type: none"> Change filter cartridge Change filter cartridge
The solenoid valve or regulator "hiss"	<ul style="list-style-type: none"> Poor air quality, dirty membranes Membrane failure 	<ul style="list-style-type: none"> Install air filter at inlet Clean/change regulator/solenoid valve
The motor is not starting	<ul style="list-style-type: none"> No power supply from the mains The machine is not set to stand-by mode The inverter is in blocked state 	<ul style="list-style-type: none"> Check power supply Press button "1" to enable inverter start Find (alphanumeric) error code and check against inverter errors chart
The motor stops	<ul style="list-style-type: none"> No power supply from the mains The inverter is in blocked state Inverter/motor overload 	<ul style="list-style-type: none"> Check power supply Find (alphanumeric) error code and check against inverter errors chart Check inverter and machine cooling fan cleaning; ensure that dedusting device and filter cartridge are properly working.
Filter is not automatically cleaned	<ul style="list-style-type: none"> No compressed air feed Dedusting device is stuck Faulty timer Faulty solenoid valve 	<ul style="list-style-type: none"> Restore compressed air feed Clean/change dedusting device Change timer Clean/change the solenoid valve
Faulty or insufficient suction	<ul style="list-style-type: none"> Filter clogged due to failure of emptying dust collector Damp filter Suction of objects Dedusting device is stuck Faulty solenoid valve Faulty timer No compressed air feed 	<ul style="list-style-type: none"> Empty dust collector bag more frequently, an excessive quantity of accumulated dust clogs the filter cartridge Check for condensate in the machine accumulation tank. Install a filter at machine inlet Check the correct machine suction value after disconnecting the tube suction value is correct. If suction is correct, system took in something that jams air passage in tube. Remove jamming. See above See above See above See above
With openings open, differential pressure gauge displayed pressure is considerably different from zero	<ul style="list-style-type: none"> Clogged filter Clogged filters Broken pressure gauge 	<ul style="list-style-type: none"> See above Clean the connection tube filters and connect them again to pressure gauge Replace the pressure gauge

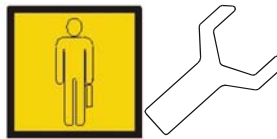

7.2 AFTER-SALES SERVICE

The Manufacturer is always willing to answer Customer's questions and give information on use, maintenance or installation and so on. Please follow the instructions given under paragraph 1.2 on how to request our assistance.

8 SPARE PARTS

8.1 SPARE PARTS LIST

Exhauster use does involve some expendable parts. Following is the list of available spare parts and expendable parts.

Table 8.1- A

POS.	DESCRIPTION	PART NO.
1	Side-channel blower	55: SK55-1-S-ST
2	Solenoid valve	9029
3	Pressure regulator	PCX-0044
4	Pressure gauge	K2-78
5	Silencer	SIL-6
6	Differential pressure gauge	8153
7	Dedusting device	K5-0080
8	Filter cartridge	FCC500PT
9	Top seal	7860-0134
10	Bottom seal	7867-0134
11	Dust collection bag	99987
	Inverter	SK55-I-E-0011



8.2 ORDERING SPARE PARTS

We remind you that the machine can only be repaired by a Qualified Technician.

It is hence recommended to contact the Manufacturer After-sales Service that will make available Qualified Personnel, suitable equipment and original spare parts.

To order above-listed spare parts, please refer to paragraph 1. 2

9 SCRAPPING

9.1 DISPOSING OF WASTE

During processing, waste or rejections are created that shall be collected, recycled or disposed of, in compliance with the prevailing laws of the country where the Machine is installed.

9.2 MACHINE SCRAPPING

Upon unit scrapping, separate the plastic parts from any electrical components, that shall be sent to different waste disposal centres, as per prevailing rules.

The machine metal parts shall be divided into steel and other metals or alloys, and then routed to recycling firms.

Unit scrapping does not cause any special risk, as far as it is performed by qualified personnel with suitable equipment.

10 ANNEXES

10.1 DECLARATIONS

The following Declarations are hereby attached:

- Declaration of conformity.

10.2 DIAGRAMS

The following Diagrams are hereby attached:

- Electric circuit diagram and key;
- Pneumatic circuit diagram;
- Machine exploded view;
- Inverter instruction manual.



Electric circuit diagram

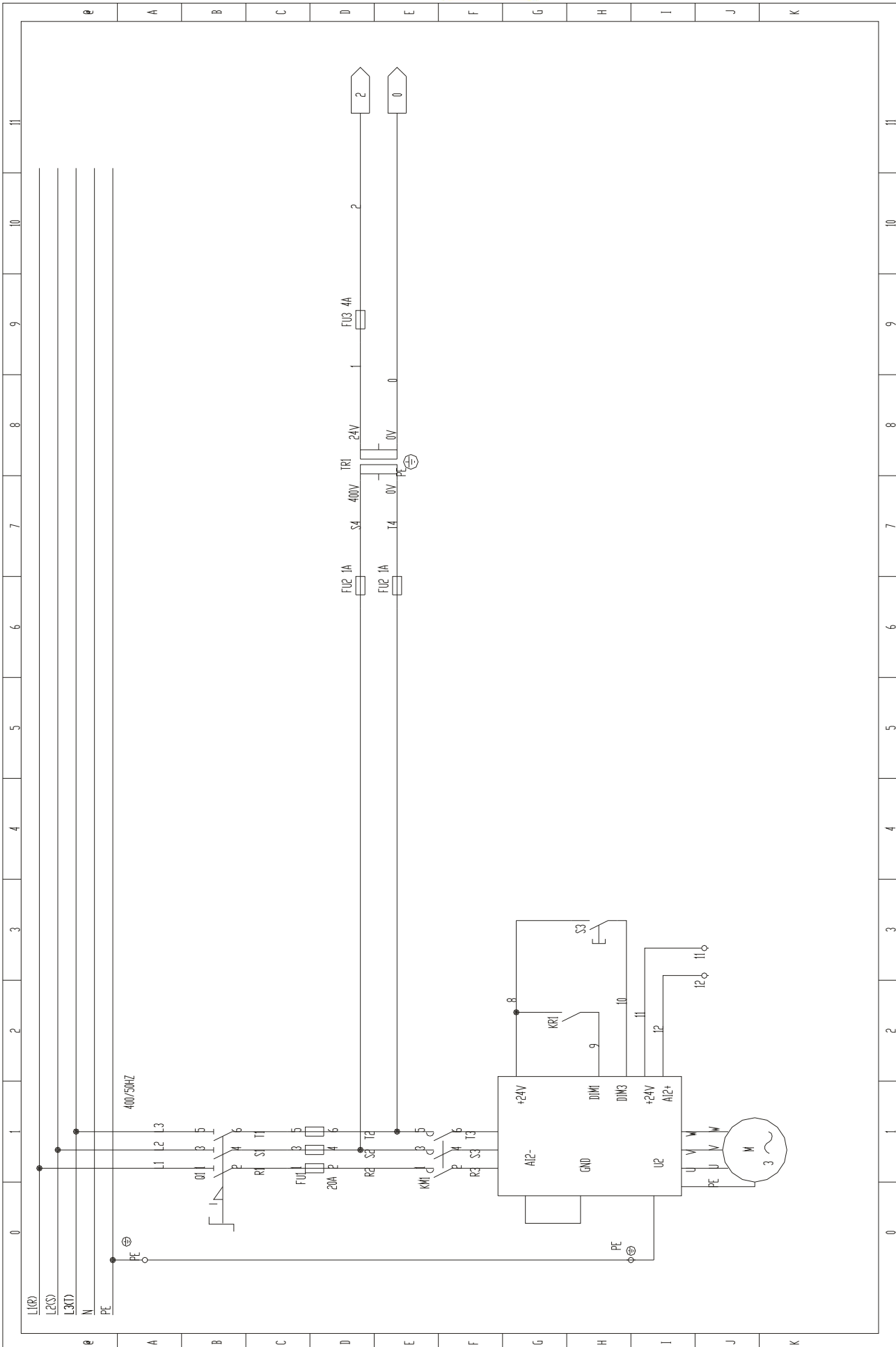

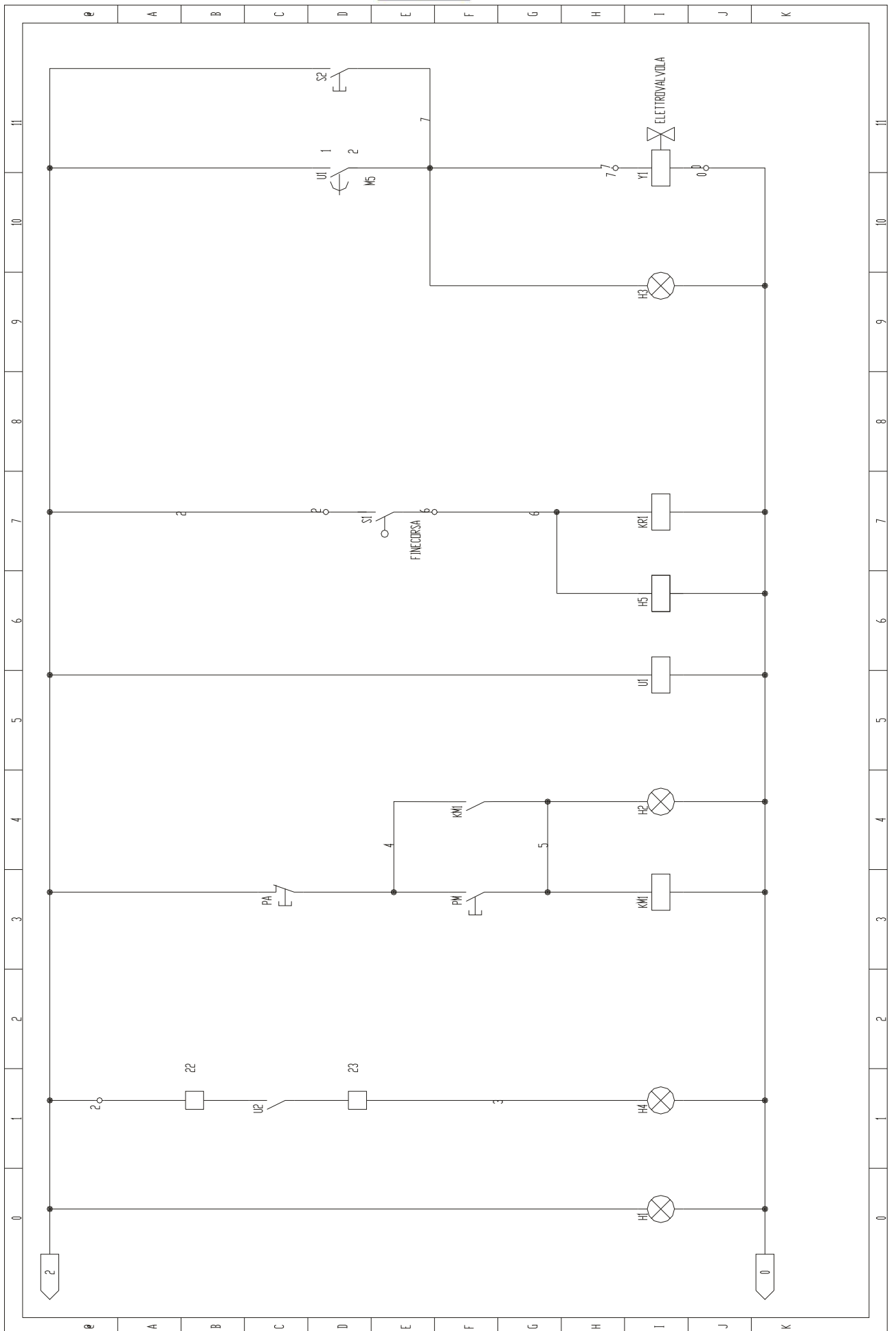

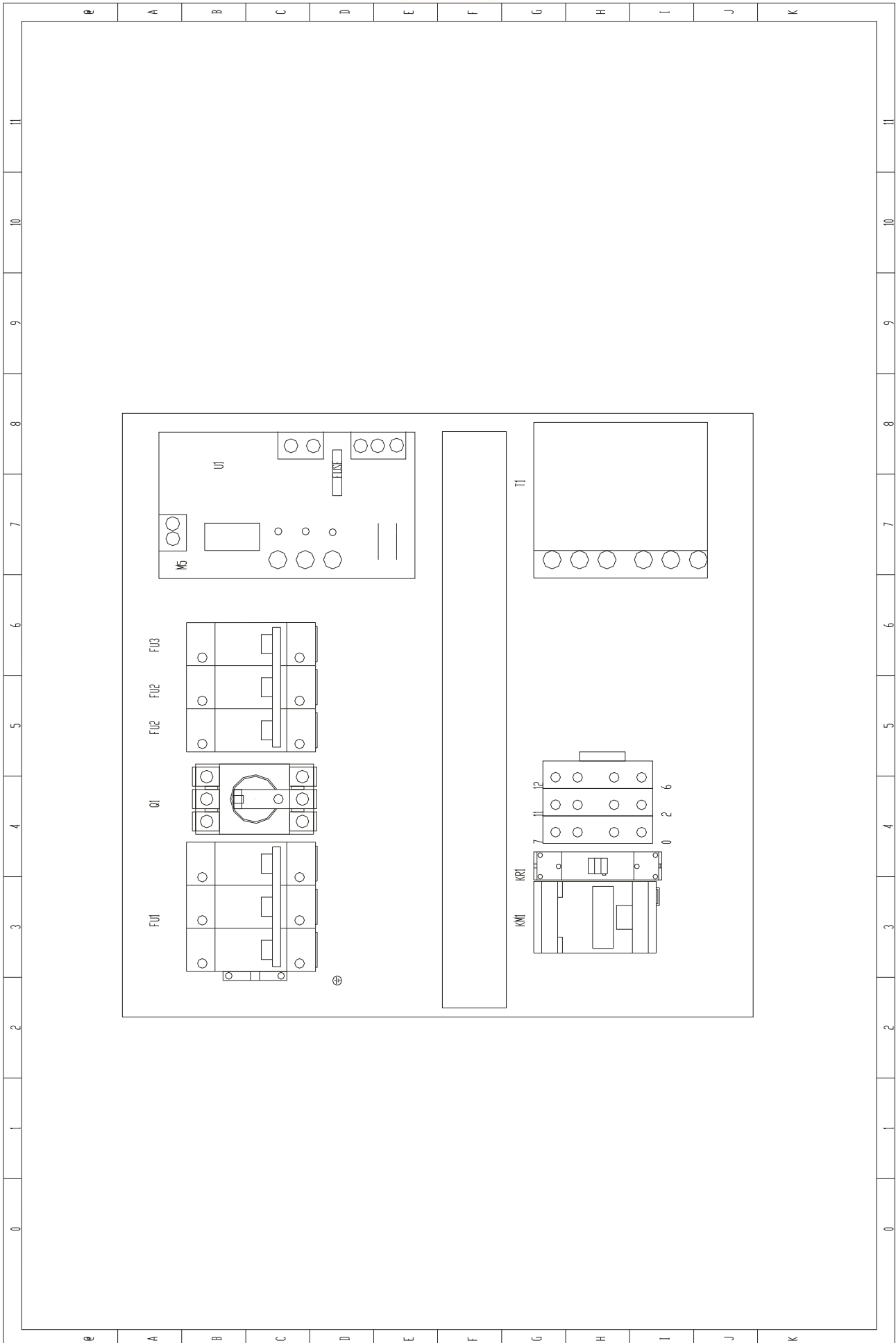

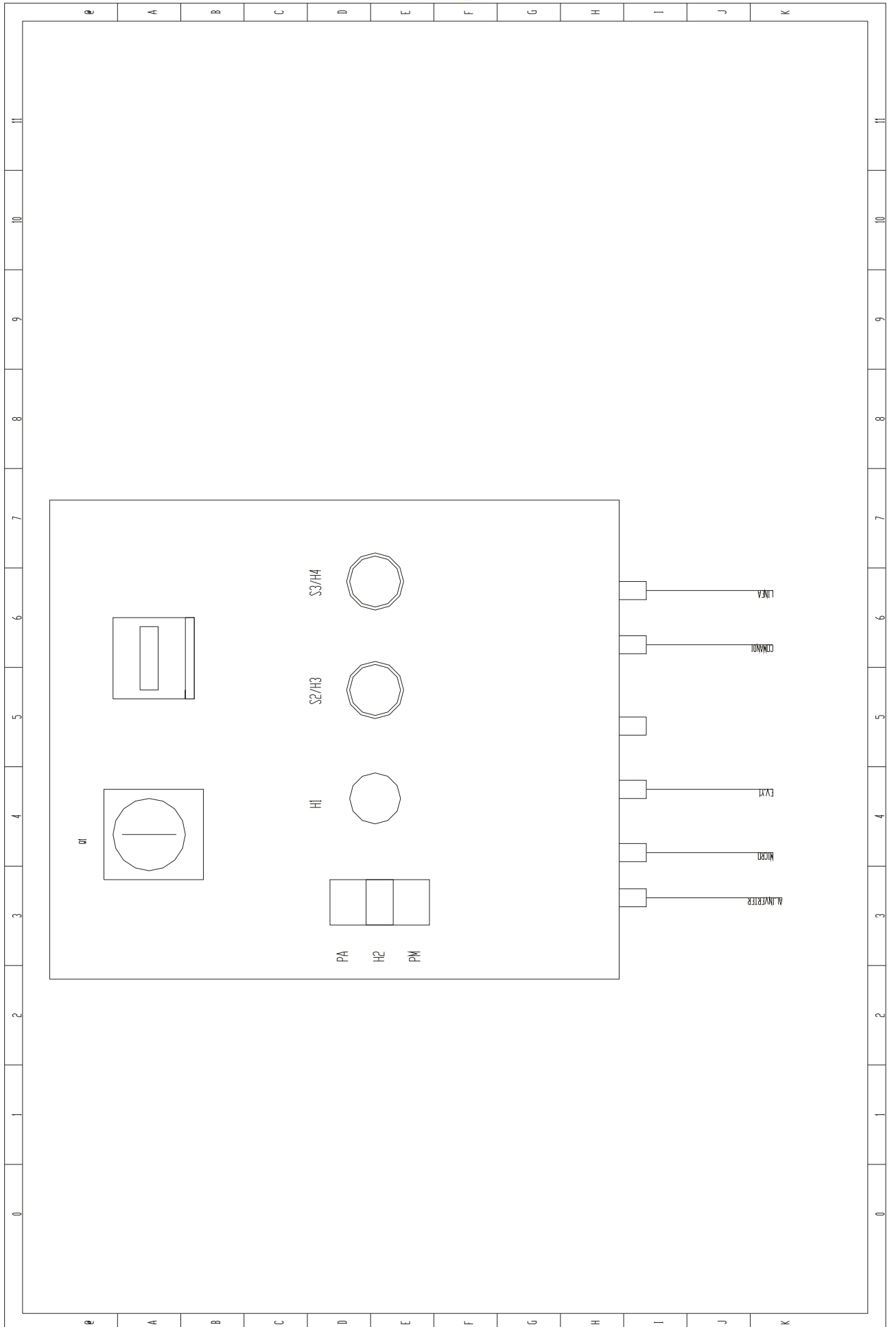



List of components - control panel

ID	Description	Manufacturer - Specs.	PART NO.
Q1	Main switch	Vantaggi Mauri	VM404
FU1	Line Fuses		10x38 - 20A
FU2	Auxiliary fuses		10x38 - 1A
FU3	Auxiliary fuses		10x38 - 4 A
KR1	Auxiliary relay	Omron	G2R2 -24V
TR1	Transformer	Trasfitalia	0-230-400/0-12-24 100VA
KM1	Contactor	TMEC	DPE18B7
U1	Board timer	CAV	9142
U2	Inverter 5.5kW	Eaton	SK55-I-E-0011
H1	Line lamp	Moller	M22-LC-W
H2	Run lamp	Moller	M22-DDL-WS+M22A+M22-LEDW
H3	Filter cleaning lamp	Moller	M22-DDL-B+M22A+M22-LEDB
H4	Reset lamp	Moller	M22-DDL-R+M22A+M22-LEDR
H5	Hour counter	Revalco	4RK46024 24V AC
S1	External start microswitch		
S2	Filter cleaning button	Moller	M22-DDL-B+M22A+M22-K10
S3	Reset button	Moller	M22-DDL-R+M22A+M22-K10
PM	Run button	Moller	M22-DDL-WS+M22A+M22-K10
PA	Stop button	Moller	M22-DDL-WS+M22A+M22-K01
Y1	Solenoid valve		

Pneumatic circuit diagram

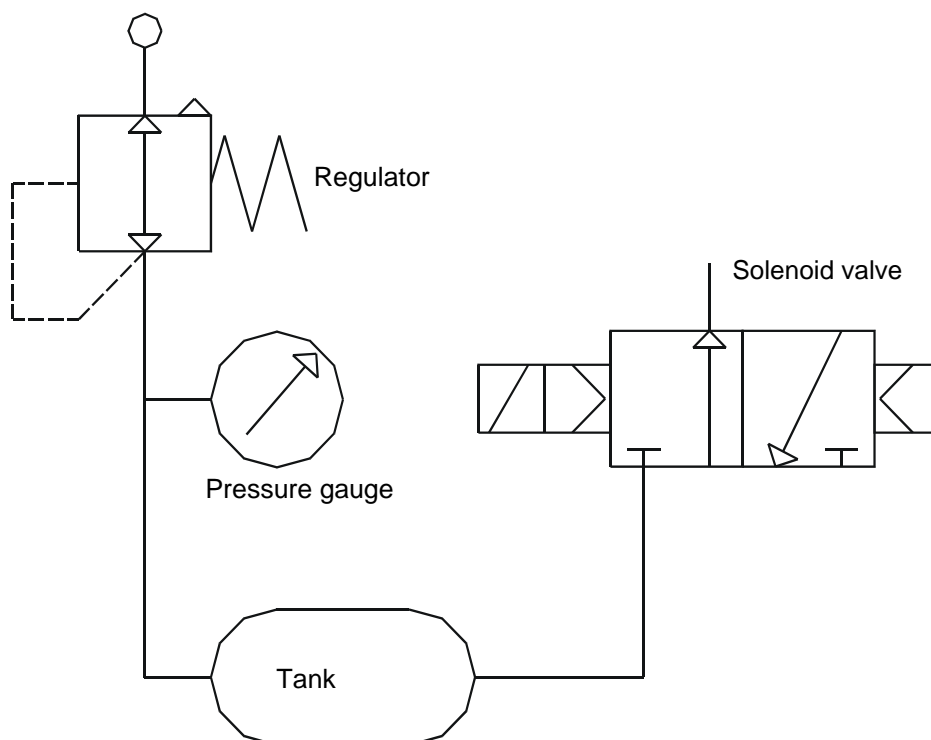

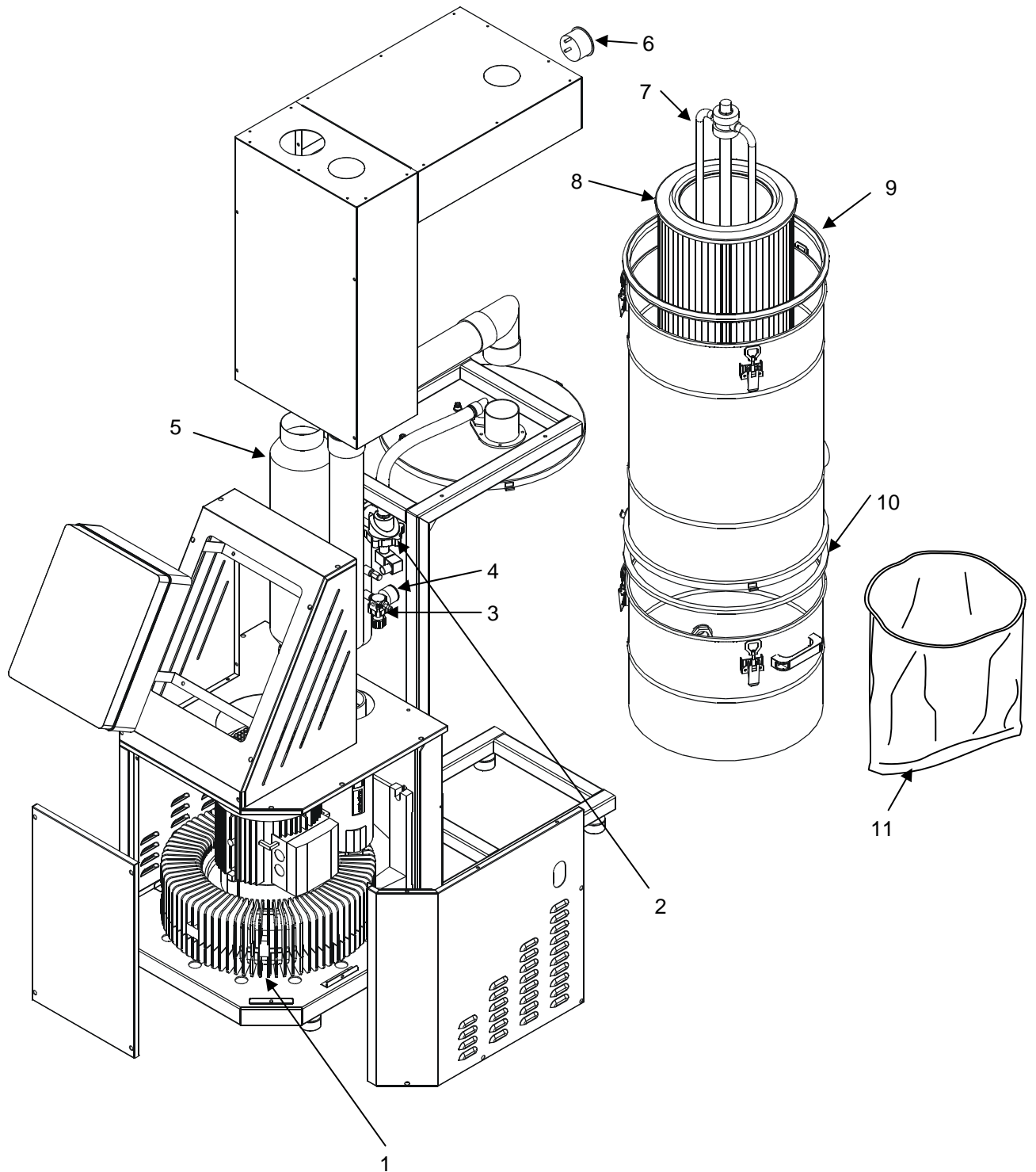

Please, see descriptions in Table 8.1 A - page 20



THE UNDERSIGNED COMPANY

C.A.V S.R.L.

VIA R. VIA MORANDI, 93 - 40060 TOSCANELLA DI DOZZA (BOLOGNA), ITALY
PHONE: +39 0542 673488 - TELEFAX: +39 0542 672065
E-MAIL: SALES@CAVITALY.COM - HTTP://WWW.CAVITALY.COM
M/BO 015576
ITALY

DECLARES, UNDER ITS OWN RESPONSIBILITY, THAT THE MACHINE

MODEL Eco 55i

SERIAL NO.:

CONSTRUCTION DATE

TO WHICH THIS DECLARATION IS REFERRED, COMPLIES WITH THE FOLLOWING DIRECTIVES:

DIRECTIVE 2006/42/EC (MACHINERY DIRECTIVE)

DIRECTIVE 2006/95/EC (LOW VOLTAGE DIRECTIVE)

DIRECTIVE 2004/108/EC (ELECTROMAGNETIC COMPATIBILITY DIRECTIVE)

FURTHERMORE, WE DECLARE THAT THE TECHNICAL DOSSIER HAS BEEN DRAWN UP BY:

LUCA LUCIA
C/O C.A.V. SRL
VIA R. MORANDI, 93 - 40060 TOSCANELLA DI DOZZA (BO)
PHONE: +39 0542 673488 - TELEFAX: +39 0542 672065
E-MAIL: UT@CAVITALY.COM

TOSCANELLA,

TECHNICAL DOSSIER DRAFTER

LUCA LUCIA

LEGAL REPRESENTATIVE

DOMENICO LUCIA





**Please fill in and return this form by fax
for Warranty registration**

Date:

Machine model:

Serial no.:

Year of manufacture:

To be filled in by the Customer

Company name

Address

Phone no.:Fax no.:E-mail:.....

Company name of installing firm

.....
.....



C.A.V. srl

Via R. Morandi, 93 - 40060 Toscanella di Dozza (BO)

Tel.: +39 0542 673488 / Fax: +39 0542 672065

www.cavitaly.com - sales@cavitaly.com

www.smaisystem.com - info@smaisystem.com



Cutler-Hammer

SLX9000 Adjustable Frequency Drives

User Manual

October 2007
Supersedes April 2006



October 2007

Important Notice – Please Read

The product discussed in this literature is subject to terms and conditions outlined in Eaton Electrical Inc. selling policies. The sole source governing the rights and remedies of any purchaser of this equipment is the relevant Eaton Electrical Inc. selling policy.

NO WARRANTIES, EXPRESS OR IMPLIED, INCLUDING WARRANTIES OF FITNESS FOR A PARTICULAR PURPOSE OR MERCHANTABILITY, OR WARRANTIES ARISING FROM COURSE OF DEALING OR USAGE OF TRADE, ARE MADE REGARDING THE INFORMATION, RECOMMENDATIONS AND DESCRIPTIONS CONTAINED HEREIN. In no event will Eaton Electrical Inc. be responsible to the purchaser or user in contract, in tort (including negligence), strict liability or otherwise for any special, indirect, incidental or consequential damage or loss whatsoever, including but not limited to damage or loss of use of equipment, plant or power system, cost of capital, loss of power, additional expenses in the use of existing power facilities, or claims against the purchaser or user by its customers resulting from the use of the information, recommendations and descriptions contained herein.

The information contained in this manual is subject to change without notice.

Cover Photo: Cutler-Hammer® SLX9000 Adjustable Frequency Drive.

Table of Contents

LIST OF FIGURES	iv
LIST OF TABLES	vi
SAFETY	viii
Definitions and Symbols	viii
Hazardous High Voltage	viii
Warnings, Cautions and Notices	ix
CHAPTER 1 — OVERVIEW	1-1
Receiving and Inspection	1-1
Storage	1-2
Maintenance	1-2
Technical Data	1-2
CHAPTER 2 — INSTALLATION	2-1
Mounting	2-1
Cooling	2-9
Changing EMC Protection Class from H to T	2-10
CHAPTER 3 — POWER WIRING	3-1
Power Connections	3-1
Installation Guidelines	3-8
CHAPTER 4 — CONTROL WIRING	4-1
Control Unit	4-1
Control Connections	4-2
Motor Thermistor (PTC) Connection	4-9
CHAPTER 5 — MENU INFORMATION	5-1
Keypad Operation	5-1
Indicators on the Keypad Display	5-1
Numeric Indicators	5-2
Keypad Pushbuttons	5-3
Menu Navigation	5-4
CHAPTER 6 — START-UP	6-1
Safety Precautions	6-1
Sequence of Operation	6-2
Start-Up Wizard	6-4
CHAPTER 7 — BASIC APPLICATION	7-1
Monitoring Values (Control Keypad: Menu M1)	7-2
Parameter List	7-3
CHAPTER 8 — MULTI-CONTROL APPLICATION	8-1
Introduction	8-1
Control Input/Output	8-3
Parameter Lists	8-5
Monitoring Values (Control Keypad: Menu M1)	8-6
CHAPTER 9 — DESCRIPTION OF PARAMETERS	9-1
Basic Parameters	9-1
Input Signals	9-6
Output Signals	9-10
Drive Control	9-16
Prohibit Frequencies	9-19

October 2007

Table of Contents (Continued)

Motor Control	9-21
Protections	9-23
Auto Restart Parameters	9-31
PID Reference Parameters	9-33
Pump and Fan Control	9-40
Keypad Control Parameters	9-49
Control Signal Logic	9-50
APPENDIX A — FAULT CODES	A-1
APPENDIX B — EXPANDER BOARD OPTAA	B-1
Description of Expander Board OPTAA	B-1
I/O Terminals on OPTAA	B-1
APPENDIX C — EXPANDER BOARD OPTAI	C-1
Description of Expander Board OPTAI	C-1
I/O Terminals on OPTAI	C-1
APPENDIX D — OPTION BOARD KITS	D-1
230V, FR7 – FR8 460V and 575V Drives	D-1

List of Figures

Figure 1-1: SLX9000 Block Diagram	1-3
Figure 2-1: NEMA Type 1 and NEMA Type 12 SLX9000 Drive Dimensions, MF4 – MF6	2-2
Figure 2-2: SLX9000 Dimensions, NEMA Type 1 and NEMA Type 12 with Flange Kit, MF4 – MF6	2-3
Figure 2-3: SLX9000 Dimensions, NEMA Type 1 and NEMA Type 12 with Flange Opening, MF4 – MF6	2-4
Figure 2-4: SLX9000 Dimensions, NEMA Type 1 and NEMA Type 12, FR7	2-5
Figure 2-5: SLX9000 Dimensions, NEMA Type 1 and NEMA Type 12, FR8	2-6
Figure 2-6: SLX9000 Dimensions, NEMA Types 1 and 12, FR7 and FR8 with Flange Kit	2-7
Figure 2-7: SLX9000 Dimensions, NEMA Types 1 and 12, FR7 and FR8 with Flange Opening	2-8
Figure 2-8: Installation Space	2-9
Figure 2-9: Changing of EMC Protection Class, MF4 (left) and MF5 (right), 460V	2-10
Figure 2-10: Changing of EMC Protection Class, MF6	2-10
Figure 3-1: Power Connections, MF4 – MF6	3-1
Figure 3-2: FR7 Power and Motor Wiring Terminals	3-1
Figure 3-3: FR8 Power and Motor Wiring Terminals	3-2
Figure 3-4: Cable Accessories	3-5
Figure 3-5: Stripping of Cables	3-9
Figure 3-6: SLX9000, MF4	3-10
Figure 3-7: Cable Installation in SLX9000, MF4	3-10
Figure 3-8: SLX9000, MF5	3-11
Figure 3-9: Cable Installation in SLX9000, MF5	3-11
Figure 3-10: SLX9000, MF6	3-12
Figure 3-11: Cable Installation in SLX9000, MF6	3-12
Figure 3-12: SLX9000, FR7	3-13
Figure 3-13: Cable Installation in SLX9000, FR7	3-13
Figure 3-14: SLX9000, FR8	3-14
Figure 3-15: Cable Installation in SLX9000, FR8	3-14
Figure 4-1: Option Board Slots D and E in Frames MF4 – MF6	4-1
Figure 4-2: Option Board Slots	4-2
Figure 4-3: Control Connections, MF4 – MF6 460V	4-2
Figure 4-4: Jumper Selection for SLX9000, MF4 – MF6	4-7
Figure 4-5: Location of Jumper Blocks in the Control Board of MF4 – MF6, 460V	4-8
Figure 4-6: Motor Thermistor (PTC) Connection	4-9
Figure 5-1: Control Keypad and Drive Status Indications	5-1
Figure 5-2: Keypad Pushbuttons	5-3
Figure 5-3: Keypad Display Data	5-4
Figure 5-4: Keypad Navigation Chart	5-5
Figure 5-5: Monitoring Menu	5-7
Figure 5-6: Parameter Value Change Procedure	5-9
Figure 5-7: Selection of Control Place	5-10
Figure 5-8: Normal State, No Faults	5-11
Figure 5-9: Fault Display	5-12
Figure 5-10: Fault History Menu	5-12
Figure 5-11: Storing and Loading of Parameter Sets	5-15
Figure 5-12: Parameter Locking	5-16

October 2007

List of Figures (Continued)

Figure 5-13: Default Page Function	5-17
Figure 5-14: Timeout Time Setting	5-17
Figure 5-15: HMI Acknowledge Timeout	5-19
Figure 5-16: MWh Counter Reset	5-20
Figure 5-17: Expander Board Information Menu	5-22
Figure 5-18: Modbus Interface	5-22
Figure 6-1: SLX9000 Start-Up Wizard	6-4
Figure 9-1: Jumper Selections of X4/X8 When AI1 Functions as DIN4	9-6
Figure 9-2: AI1 Signal Selection	9-7
Figure 9-3: AI1 Signal Filtering	9-8
Figure 9-4: Without (Left) and With (Right) Reference Scaling	9-10
Figure 9-5: Analog Output Filtering	9-12
Figure 9-6: Analog Output Invert	9-13
Figure 9-7: Analog Output Scaling	9-14
Figure 9-8: Output Frequency Supervision	9-15
Figure 9-9: Relay Output 1 ON- and OFF-Delays	9-16
Figure 9-10: Acceleration/Deceleration (S-Shaped)	9-16
Figure 9-11: DC-Braking Time When Stop Mode = Coasting	9-18
Figure 9-12: DC-Braking Time When Stop Mode = Ramp	9-18
Figure 9-13: DC Braking Time at Start	9-19
Figure 9-14: Prohibit Frequency Area Setting	9-20
Figure 9-15: Ramp Speed Scaling Between Prohibit Frequencies	9-20
Figure 9-16: Linear and Squared Change of Motor Voltage	9-21
Figure 9-17: Programmable VHz Curve	9-22
Figure 9-18: Motor Cooling Power	9-26
Figure 9-19: Motor Temperature Calculation	9-27
Figure 9-20: Stall Characteristics Settings	9-28
Figure 9-21: Stall Time Count	9-28
Figure 9-22: Setting of Minimum Load	9-30
Figure 9-23: Underload Time Counter Function	9-30
Figure 9-24: Automatic Restart	9-32
Figure 9-25: PID Controller Function as I-Controller	9-34
Figure 9-26: PID Output Curve with the Values of Example 2	9-35
Figure 9-27: PID Output with the Values of Example 3	9-36
Figure 9-28: Example of Actual Value Signal Scaling	9-37
Figure 9-29: Sleep Function	9-38
Figure 9-30: 3-Pump Autochange System, Principal Control Diagram	9-43
Figure 9-31: Example of 3-Pump Autochange, Main Diagram	9-43
Figure 9-32: 2-Pump Autochange System, Principal Control Diagram	9-45
Figure 9-33: Example of 2-Pump Autochange, Main Diagram	9-45
Figure 9-34: Autochange Applied to Auxiliary Drives Only	9-46
Figure 9-35: Autochange with All Drives	9-47
Figure 9-36: Autochange Interval and Limits	9-48
Figure 9-37: Control Signal Logic of the Multi-Control Application	9-50
Figure B-1: Expander Board OPTAA	B-1
Figure C-1: Expander Board OPTAI	C-1
Figure D-1: Option Boards	D-1

List of Tables

Table 1-1: SLX9000 AF Drive Catalog Numbering System	1-1
Table 1-2: 208 – 240V, NEMA Type 1 Power Ratings	1-4
Table 1-3: 208 – 240V, NEMA Type 12 Power Ratings	1-4
Table 1-4: 380 – 500V, NEMA Type 1 Power Ratings	1-5
Table 1-5: 380 – 500V, NEMA Type 12 Power Ratings	1-5
Table 1-6: 525 – 690V, NEMA Type 1 Power Ratings	1-6
Table 1-7: 525 – 690V, NEMA Type 12 Power Ratings	1-6
Table 1-8: Technical Information	1-7
Table 2-1: SLX9000 Drive Dimensions	2-2
Table 2-2: Dimensions for SLX9000, MF4 – MF6 with Flange Kit	2-3
Table 2-3: Dimensions for the Flange Opening, MF4 – MF6	2-4
Table 2-4: SLX9000 Dimensions, FR7	2-5
Table 2-5: SLX9000 Dimensions, FR8	2-6
Table 2-6: SLX9000 Dimensions, NEMA Types 1 and 12, FR7 and FR8 with Flange Kit	2-7
Table 2-7: SLX9000 Dimensions, NEMA Types 1 and 12, for the Flange Opening, FR7/FR8.	2-8
Table 2-8: Mounting Space Dimensions	2-9
Table 2-9: Required Cooling Air.	2-9
Table 3-1: Cable Types Required to Meet Standards	3-3
Table 3-2: Cable and Fuse Sizes – 230V Ratings.	3-3
Table 3-3: Cable and Fuse Sizes – 480V Ratings.	3-4
Table 3-4: Cable and Fuse Sizes – 575V Ratings.	3-4
Table 3-5: Mounting Procedure	3-6
Table 3-6: Cable Spacings	3-8
Table 3-7: Cable Stripping Lengths	3-9
Table 3-8: Tightening Torques of Terminals	3-15
Table 4-1: Multi-Control Application Default Input/Output Configuration, MF4 – MF6 460V	4-3
Table 4-2: AI1 Configuration, When Programmed as DIN4, MF4 – MF6 460V	4-3
Table 4-3: Default I/O Configuration, All 230V, FR7 – FR8 460V and All 575V	4-4
Table 4-4: Control Input/Output Terminal Signals, MF4 – MF6 460V	4-5
Table 4-5: Option Board A9 Terminal Descriptions, All 230V, FR7 – FR8 460V and All 575V.	4-6
Table 4-6: Option Board A2 Terminal Descriptions, All 230V, FR7 – FR8 460V and All 575V.	4-7
Table 5-1: Drive Status Indicators	5-2
Table 5-2: Control Place Indicators	5-2
Table 5-3: Button Descriptions	5-3
Table 5-4: Main Menu Functions	5-6
Table 5-5: Monitored Signals	5-8
Table 5-6: Keypad Control Menu Selections.	5-10
Table 5-7: Fault Types	5-12
Table 5-8: System Menu Functions	5-13
Table 5-9: Counter Pages	5-19
Table 5-10: Trip Counter Pages	5-20
Table 5-11: Software Information Pages.	5-20
Table 5-12: Application Information Pages.	5-21
Table 5-13: Hardware Information Pages	5-21
Table 5-14: Connected Options Submenu	5-21

October 2007

List of Tables (Continued)

Table 5-15: Modbus Commands Supported by SLX9000	5-23
Table 5-16: Output Process Data	5-24
Table 5-17: Input Process Data	5-24
Table 5-18: Status Word	5-24
Table 5-19: Actual Speed	5-24
Table 5-20: Control Word	5-25
Table 5-21: Speed Reference	5-25
Table 5-22: Bit Definitions	5-25
Table 7-1: Monitoring Values	7-2
Table 7-2: Basic Parameters (Control Keypad: Menu P2 → B2.1)	7-3
Table 8-1: Multi-Control Application Default Input/Output Configuration, MF4 – MF6 460V	8-3
Table 8-2: AI1 Configuration, When Programmed as DIN4	8-3
Table 8-3: Default I/O Configuration, All 230V, FR7 – FR8 460V and All 575V	8-4
Table 8-4: Monitoring Values	8-6
Table 8-5: Basic Parameters P2.1	8-7
Table 8-6: Input Signals, P2.2	8-9
Table 8-7: Output Signals, G2.3	8-11
Table 8-8: Drive Control Parameters, P2.4	8-12
Table 8-9: Prohibit Frequency Parameters, P2.5	8-12
Table 8-10: Motor Control Parameters, P2.6	8-13
Table 8-11: Protections, P2.7	8-13
Table 8-12: Autorestart Parameters, P2.8	8-14
Table 8-13: PID Reference Parameters, P2.9	8-15
Table 8-14: Pump and Fan Control Parameters, P2.10	8-16
Table 8-15: Keypad Control Parameters, K3	8-16
Table 9-1: Output Signals via RO1 and Expander Board RO1, RO2 and DO1	9-11
Table 9-2: Analog Output Scaling	9-14
Table 9-3: Selectable Wake-Up Functions	9-39
Table 9-4: PFC-Control Input/Output Configuration with Three Pumps, MF4 – MF6 460V	9-42
Table 9-5: PFC-Control Input/Output Configuration with Two Pumps, MF4 – MF6 460V	9-44
Table A-1: Fault Codes	A-1
Table B-1: I/O Terminals of Board OPTAA	B-1
Table C-1: I/O Terminals of Board OPTAI	C-1
Table D-1: Option Board Kits	D-1

Safety

Definitions and Symbols

 WARNING

This symbol indicates high voltage. It calls your attention to items or operations that could be dangerous to you and other persons operating this equipment. Read the message and follow the instructions carefully.



This symbol is the "Safety Alert Symbol." It occurs with either of two signal words: CAUTION or WARNING, as described below.

 WARNING

Indicates a potentially hazardous situation which, if not avoided, can result in serious injury or death.

 CAUTION

Indicates a potentially hazardous situation which, if not avoided, can result in minor to moderate injury, or serious damage to the product. The situation described in the CAUTION may, if not avoided, lead to serious results. Important safety measures are described in CAUTION (as well as WARNING).

Hazardous High Voltage

 WARNING

Motor control equipment and electronic controllers are connected to hazardous line voltages. When servicing drives and electronic controllers, there may be exposed components with housings or protrusions at or above line potential. Extreme care should be taken to protect against shock.

Stand on an insulating pad and make it a habit to use only one hand when checking components. Always work with another person in case an emergency occurs. Disconnect power before checking controllers or performing maintenance. Be sure equipment is properly grounded. Wear safety glasses whenever working on electronic controllers or rotating machinery.

October 2007

Warnings, Cautions and Notices

Read this manual thoroughly and make sure you understand the procedures before you attempt to install, set up, or operate this Cutler-Hammer® SLX9000 Adjustable Frequency Drive from Eaton's electrical business.

Warnings

⚠ WARNING

Only a competent electrician may carry out the electrical installation.

⚠ WARNING

The components of the power unit of the drive are live when the SLX9000 drive is connected to power supply. Coming into contact with this voltage is extremely dangerous and may cause death or severe injury. The control unit is isolated from mains potential.

⚠ WARNING

The motor terminals U, V, W (T1, T2, T3) and the DC-link/brake resistor terminals -/+ (in SLX9000 ≥ 1.1 kW) are **live** when drive is connected to mains, **even if the motor is not running**. Contact with this voltage is extremely dangerous and may cause death or severe injury.

⚠ WARNING

The control I/O-terminals are isolated from the mains potential. However, the relay outputs and other I/O-terminals may have dangerous control voltage present even when the drive is disconnected from the power supply. Contact with this voltage is extremely dangerous and may cause death or severe injury.

⚠ WARNING

The drive has a large capacitive leakage current. Proper grounding is required. Failure to observe this precaution could result in death or severe injury.

⚠ WARNING

If the drive is used as a part of a machine, the machine manufacturer is responsible for providing the machine with a main switch (EN 60204-1).

⚠ WARNING

Only spare parts delivered by Eaton can be used.

⚠ WARNING

If the motor thermistor is connected to DIN3, the instructions on **Page 4-9 must be** followed, otherwise a serious safety hazard may result from the connection.

Cautions

⚠ CAUTION

The SLX9000 drive is meant for fixed installations only.

⚠ CAUTION

Do not perform any measurements when the drive is connected to the power supply.

⚠ CAUTION

After having disconnected the drive from the power supply, wait until the fan stops and the indicators on the keypad go out (if no keypad is attached see the indicator through the keypad base). Wait 5 more minutes before doing any work on drive connections.

⚠ CAUTION

Do not perform any voltage withstand tests on any part of drive. There is a certain procedure according to which the tests shall be performed. Ignoring this procedure may result in damaged product.

⚠ CAUTION

Prior to measurements on the motor or the motor cable, disconnect the motor cable from the drive.

⚠ CAUTION

Do not touch the IC-circuits on the circuit boards. Static voltage discharge may damage the components.

⚠ CAUTION

Check the correct positions of the jumpers. Running the motor with signal settings different from the jumper positions will not harm the drive but may damage the motor.

⚠ CAUTION

The calculated model does not protect the motor if the airflow to the motor is reduced by blocked air intake grill.

October 2007

Grounding and ground fault protection

The SLX9000 drive must always be grounded with a ground conductor connected to the ground terminal.

The ground fault protection inside the drive only protects the drive itself against ground faults in the motor or the motor cable.

Due to the high capacity currents present in the drive, fault current protective switches may not function properly. If fault current protective switches are used, they need to be tested with ground fault currents present during possible fault situations.

Motor and Equipment Safety

 CAUTION

Before starting the motor, check that the motor is mounted properly and ensure that the machine connected to the motor allows the motor to be started.

 CAUTION

Set the maximum motor speed (frequency) according to the motor and the machine connected to it.

 CAUTION

Before reversing the motor, make sure that this can be done safely.

 CAUTION

Make sure that no power correction capacitors are connected to the motor cable.

 CAUTION

Make sure that the motor terminals are not connected to mains potential.

October 2007

Chapter 1 — Overview

Receiving and Inspection

Cutler-Hammer® SLX9000 Adjustable Frequency Drives User Manual

SLX9000 Adjustable Frequency Drives User Manual

SLX9000 Adjustable Frequency Drives User Manual from Eaton’s electrical business have undergone scrupulous tests and quality checks at the factory before they are delivered to the customer. However, after unpacking the product, check that no signs of transport damages are to be found on the product and that the delivery is complete (compare the catalog number of the product to the code below, see **Table 1-1**).

If the drive has been damaged during shipping, please contact the cargo insurance company or the carrier.

If the delivery does not correspond to your order, contact the supplier immediately.

Table 1-1: SLX9000 AF Drive Catalog Numbering System

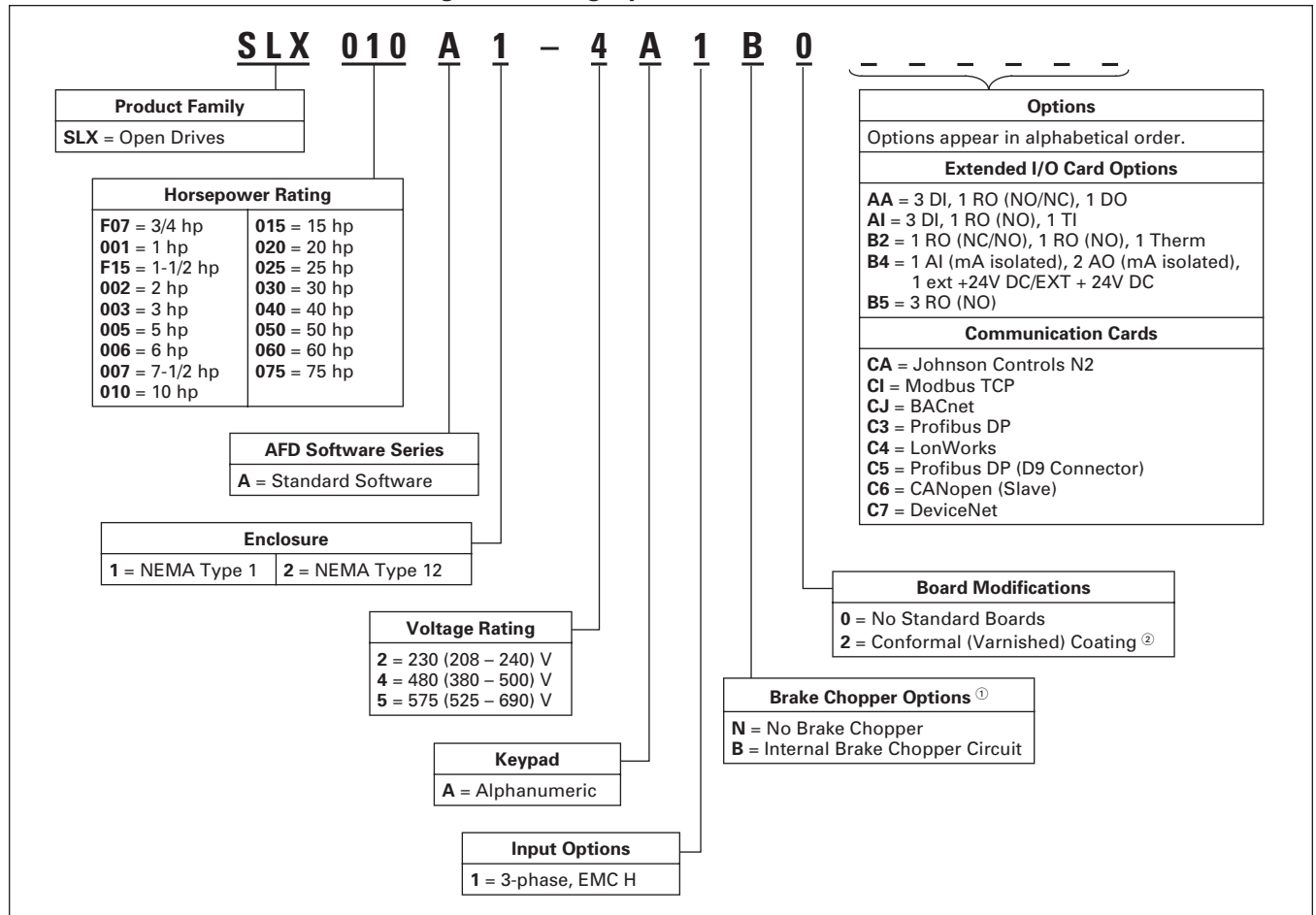

① 230V Drives up to 15 hp (I_H) and 480V Drives up to 30 hp (I_H) are only available with Brake Chopper Option B. All others come with Brake Chopper Option N as standard.

② Factory promise delivery. Consult Sales Office for availability.

Storage

If the drive is to be kept in storage before use, make sure that the ambient conditions are acceptable:

Storing temperature: -40 to 158°F (-40 to 70°C)

Relative humidity: <95%, no condensation

Maintenance

In normal conditions, Cutler-Hammer drives are maintenance-free. However, we recommend to clean the heatsink (using e.g. a small brush) whenever necessary. Most drives are equipped with a cooling fan, which can easily be changed if necessary.

Technical Data

SLX9000 is a compact drive with ratings ranging from 3/4 to 75 hp. It is well adapted for HVAC and OEM applications where its uses are almost unlimited.

The Motor and Application Control Block is based on microprocessor software. The microprocessor controls the motor basing on the information it receives through measurements, parameter settings, control I/O and control keypad. The IGBT Inverter Bridge produces a symmetrical, three-phase PWM-modulated AC-voltage to the motor.

The control keypad constitutes a link between the user and the drive. The control keypad is used for parameter setting, reading status data and giving control commands. Instead of the control keypad, a PC can also be used to control the drive if connected through a cable and a serial interface adapter (optional equipment).

The drive can be supplied with control I/O boards OPTAA, OPTAI, OPTB_ or OPTC_.

230V Drives up to 15 hp (I_H) and 480V Drives up to 30 hp (I_H) have an internal brake chopper. All other sizes come standard with no brake chopper. For more information, contact Eaton. The input EMC filters are internal and included as standard.

October 2007

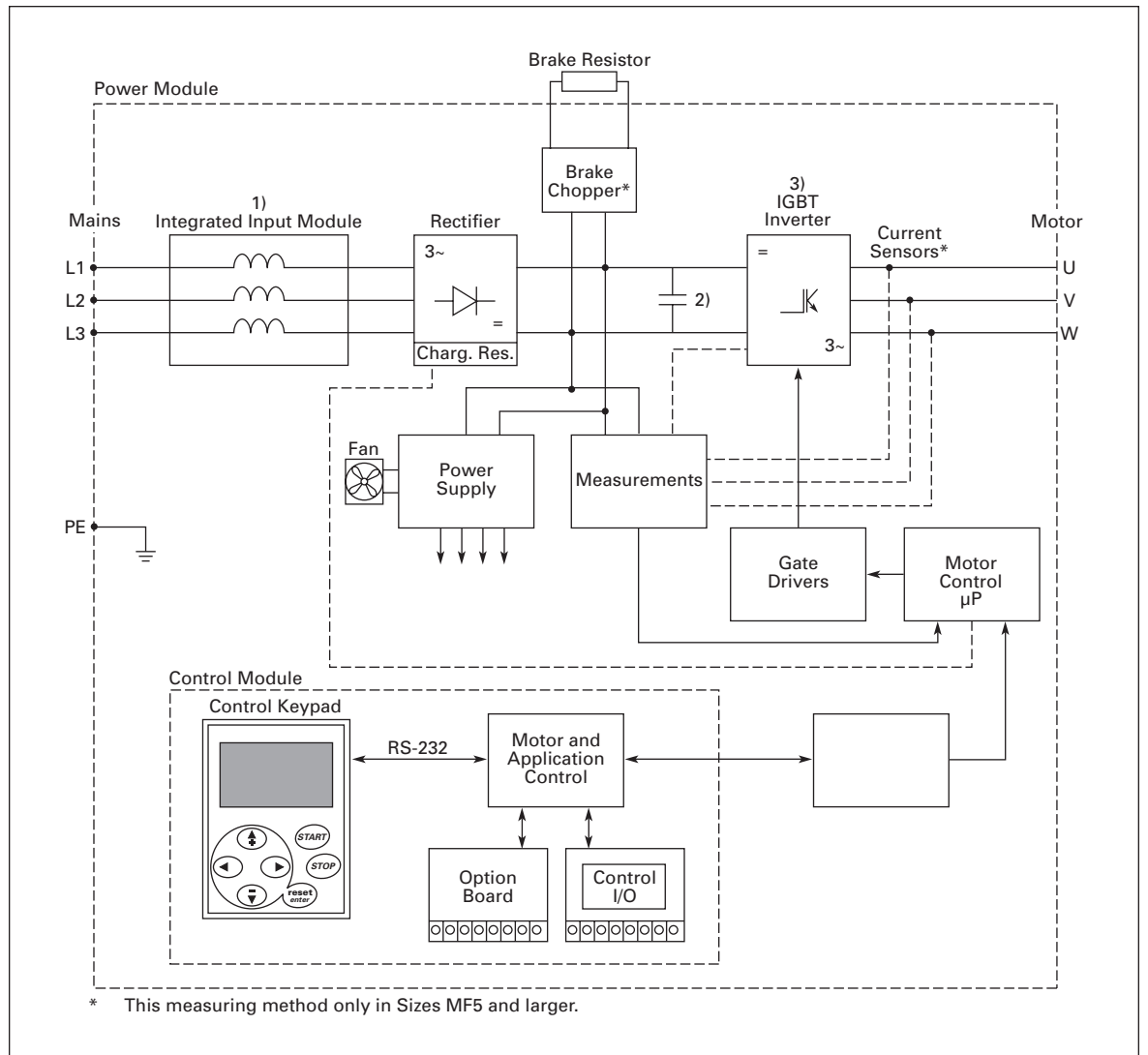

Figure 1-1: SLX9000 Block Diagram

Power Ratings**230V SLX9000 Drives****Table 1-2: 208 – 240V, NEMA Type 1 Power Ratings**

Catalog Number	Frame Size	High Overload 150% (I _H)		Low Overload 110% (I _L)	
		hp	Current Rating	hp	Current Rating
SLXF07A1-2A1B0	MF4	3/4	3.7	1	4.8
SLX001A1-2A1B0		1	4.8	1-1/2	6.6
SLXF15A1-2A1B0		1-1/2	6.6	2	7.8
SLX002A1-2A1B0		2	7.8	3	11
SLX003A1-2A1B0		3	11	—	12.5
SLX004A1-2A1B0	MF5	—	12.5	5	17.5
SLX005A1-2A1B0		5	17.5	7-1/2	25
SLX007A1-2A1B0		7-1/2	25	10	31
SLX010A1-2A1B0	MF6	10	31	15	48
SLX015A1-2A1B0		15	48	20	61
SLX020A1-2A1N0	FR7	20	61	25	75
SLX025A1-2A1N0		25	75	30	88
SLX030A1-2A1N0		30	88	40	114

Table 1-3: 208 – 240V, NEMA Type 12 Power Ratings

Catalog Number	Frame Size	High Overload 150% (I _H)		Low Overload 110% (I _L)	
		hp	Current Rating	hp	Current Rating
SLXF07A2-2A1B0	MF4	3/4	3.7	1	4.8
SLX001A2-2A1B0		1	4.8	1-1/2	6.6
SLXF15A2-2A1B0		1-1/2	6.6	2	7.8
SLX002A2-2A1B0		2	7.8	3	11
SLX003A2-2A1B0		3	11	—	12.5
SLX004A2-2A1B0	MF5	—	12.5	5	17.5
SLX005A2-2A1B0		5	17.5	7-1/2	25
SLX007A2-2A1B0		7-1/2	25	10	31
SLX010A2-2A1B0	MF6	10	31	15	48
SLX015A2-2A1B0		15	48	20	61
SLX020A2-2A1N0	FR7	20	61	25	75
SLX025A2-2A1N0		25	75	30	88
SLX030A2-2A1N0		30	88	40	114

October 2007

480V SLX9000 Drives

Table 1-4: 380 – 500V, NEMA Type 1 Power Ratings

Catalog Number	Frame Size	High Overload 150% (I _H)		Low Overload 110% (I _L)	
		hp	Current Rating	hp	Current Rating
SLX001A1-4A1B0	MF4	1	2.2	1-1/2	3.3
SLXF15A1-4A1B0		1-1/2	3.3	2	4.3
SLX002A1-4A1B0		2	4.3	3	5.6
SLX003A1-4A1B0		3	5.6	4	7.6
SLX005A1-4A1B0		4	7.6	5	9
SLX006A1-4A1B0		5	9	7-1/2	12
SLX007A1-4A1B0	MF5	7-1/2	12	10	16
SLX010A1-4A1B0		10	16	15	23
SLX015A1-4A1B0		15	23	20	31
SLX020A1-4A1B0	MF6	20	31	25	38
SLX025A1-4A1B0		25	38	30	46
SLX030A1-4A1B0		30	46	40	61
SLX040A1-4A1N0	FR7	40	61	50	72
SLX050A1-4A1N0		50	72	60	87
SLX060A1-4A1N0		60	87	75	105
SLX075A1-4A1N0	FR8	75	105	100	140

Table 1-5: 380 – 500V, NEMA Type 12 Power Ratings

Catalog Number	Frame Size	High Overload 150% (I _H)		Low Overload 110% (I _L)	
		hp	Current Rating	hp	Current Rating
SLX001A2-4A1B0	MF4	1	2.2	1-1/2	3.3
SLXF15A2-4A1B0		1-1/2	3.3	2	4.3
SLX002A2-4A1B0		2	4.3	3	5.6
SLX003A2-4A1B0		3	5.6	4	7.6
SLX005A2-4A1B0		4	7.6	5	9
SLX006A2-4A1B0		5	9	7-1/2	12
SLX007A2-4A1B0	MF5	7-1/2	12	10	16
SLX010A2-4A1B0		10	16	15	23
SLX015A2-4A1B0		15	23	20	31
SLX020A2-4A1B0	MF6	20	31	25	38
SLX025A2-4A1B0		25	38	30	46
SLX030A2-4A1B0		30	46	40	61
SLX040A2-4A1N0	FR7	40	61	50	72
SLX050A2-4A1N0		50	72	60	87
SLX060A2-4A1N0		60	87	75	105
SLX075A2-4A1N0	FR8	75	105	100	140

575V SLX9000 Drives

Table 1-6: 525 – 690V, NEMA Type 1 Power Ratings

Catalog Number	Frame Size	High Overload 150% (I _H)		Low Overload 110% (I _L)	
		hp	Current Rating	hp	Current Rating
SLX002A1-5A1N0	MF6	2	3.33	3	4.5
SLX003A1-5A1N0		3	4.5	—	5.5
SLX004A1-5A1N0		—	5.5	5	7.5
SLX005A1-5A1N0		5	7.5	7-1/2	10
SLX007A1-5A1N0		7-1/2	10	10	13.5
SLX010A1-5A1N0		10	13.5	15	18
SLX015A1-5A1N0		15	18	20	22
SLX020A1-5A1N0		20	22	25	27
SLX025A1-5A1N0		25	27	30	34
SLX030A1-5A1N0	FR7	30	34	40	41
SLX040A1-5A1N0		40	41	50	52
SLX050A1-5A1N0	FR8	50	52	60	62
SLX060A1-5A1N0		60	62	75	80
SLX075A1-5A1N0		75	80	100	100

Table 1-7: 525 – 690V, NEMA Type 12 Power Ratings

Catalog Number	Frame Size	High Overload 150% (I _H)		Low Overload 110% (I _L)	
		hp	Current Rating	hp	Current Rating
SLX002A2-5A1N0	MF6	2	3.33	3	4.5
SLX003A2-5A1N0		3	4.5	—	5.5
SLX004A2-5A1N0		—	5.5	5	7.5
SLX005A2-5A1N0		5	7.5	7-1/2	10
SLX007A2-5A1N0		7-1/2	10	10	13.5
SLX010A2-5A1N0		10	13.5	15	18
SLX015A2-5A1N0		15	18	20	22
SLX020A2-5A1N0		20	22	25	27
SLX025A2-5A1N0		25	27	30	34
SLX030A2-5A1N0	FR7	30	34	40	41
SLX040A2-5A1N0		40	41	50	52
SLX050A2-5A1N0	FR8	50	52	60	62
SLX060A2-5A1N0		60	62	75	80
SLX075A2-5A1N0		75	80	100	100

October 2007

Table 1-8: Technical Information

Description	Specification
Mains Connection	
Input Voltage V_{in}	208 – 240V; -15% to +10% three-phase 380 – 500V; -15% to +10% three-phase 525 – 690V; -15% to +10% three-phase
Input Frequency	45 – 66 Hz
Connection to Mains	Once per minute or less (typical application)
Motor Connection	
Output Voltage	0 – V_{in}
Continuous Output Current	I_H : Ambient temperature max. 122°F (+50°C), overload 1.5 x I_H (1 min./10 min.) I_L : Ambient temperature max. 104°F (+40°C), overload 1.1 x I_L (1 min./10 min.)
Starting Torque	150% (Low overload); 200% (High overload)
Starting Current	2 x I_H 2 secs every 20 secs, if output frequency <30 Hz and temperature of heatsink <+60°C
Output Frequency	0 – 320 Hz
Frequency Resolution	.01 Hz
Control Characteristics	
Control Method	Frequency control V/f Open Loop Sensorless Vector Control
Switching Frequency (See Parameter 2.6.8)	208 – 230V: 3/4 – 15 hp: 1 to 16 kHz; default 10 kHz 20 – 30 hp: 1 to 10 kHz; default 3.6 kHz 380 – 500V: 1 – 30 hp: 1 to 16 kHz; default 10 kHz 40 – 60 hp: 1 to 10 kHz; default 3.6 kHz 525 – 690V: All Sizes: 1 to 6 kHz; default 1.5 kHz
Frequency Reference – Analog Input – Keypad Reference	Resolution .1% (10-bit), accuracy ±1% Resolution .01 Hz
Field Weakening Point	30 – 320 Hz
Acceleration Time	.1 – 3000 sec.
Deceleration Time	.1 – 3000 sec.
Braking Torque	DC brake: 30%* T_N (without brake option)
Ambient Conditions	
Ambient Operating Temperature	14°F (-10°C) (no frost) to 122°F (50°C): I_H 14°F (-10°C) (no frost) to 104°F (40°C): I_L
Storage Temperature	-40 to 158°F (-40 to 70°C)
Relative Humidity	0 – 95% RH, non-condensing, non-corrosive, no dripping water
Air Quality: – Chemical Vapors – Mechanical Particles	IEC 721-3-3, unit in operation, class 3C2 IEC 721-3-3, unit in operation, class 3S2
Altitude	100% load capacity (no derating) up to 3300 ft. (1000m) 1-% derating for each 330 ft. (100m) above 3300 ft. (1000m); max. 10000 ft. (3000m)

Table 1-8: Technical Information (Continued)

Description	Specification
Ambient Conditions (Continued)	
Vibration EN 50178/EN 60068-2-6	5 – 150 Hz Displacement amplitude 1 mm (peak) at 5 – 15.8 Hz Max acceleration amplitude 1G at 15.8 – 150 Hz
Shock EN 50178, IEC 68-2-27	UPS Drop Test (for applicable UPS weights) Storage and shipping: max 15G, 11 mS (in package)
Enclosure Class	NEMA Type 1/IP21 or NEMA Type 12/IP54
EMC	
Immunity	Complies with EN 50082-1, -2, EN 61800-3
Emissions	MF4 – MF6: EMC-level H: EN 61800-3 (1996)+A11 (2000) 1. environment, restricted use; 2. environment
Safety	
	EN 50178, EN 60204-1, CE, UL, cUL, FI, GOST R, IEC 61800-5 (see unit nameplate for more detailed approvals)
Control Connections	
Analog Input Voltage	0 – 10V, $R_i = 200\text{ k}\Omega$, Resolution 10 bit, accuracy $\pm 1\%$
Analog Input Current	0(4) – 20 mA, $R_i = 250\Omega$ differential
Digital Inputs	3 positive logic; 18 – 24V DC
Auxiliary Voltage	+24V, $\pm 15\%$, max. 100 mA
Output Reference Voltage	+10V, +3%, max. load 10 mA
Analog Output	0(4) – 20 mA; R_L max. 500 Ω ; Resolution 16 bit; Accuracy $\pm 1\%$
Relay Outputs	1 programmable change-over relay output Switching capacity: 24V DC/8A, 250V AC/8A, 125V DC/.4A
Protections	
Overvoltage Protection	Yes
Undervoltage Protection	Yes
Ground Fault Protection	In case of ground fault in motor or motor cable, only the drive is protected
Unit Overtemperature Protection	Yes
Motor Overload Protection	Yes
Motor Stall Protection	Yes
Motor Underload Protection	Yes
Short Circuit Protection of +24V and +10V Reference Voltages	Yes
Overcurrent Protection	Trip limit $4.0 \cdot I_H$ instantaneously

October 2007

Chapter 2 — Installation

Mounting

Standard Mounting Instructions

1. Measure the mounting space to ensure that it allows for the minimum space surrounding the drive. See dimension tables and **Table 2-8**.
2. Make sure the mounting surface is flat and strong enough to support the drive, is not flammable, and is not subject to excessive motion or vibration.
3. Ensure that the minimum airflow requirements for your drive are met at the mounting location. See **Table 2-9**.
4. Mark the location of the mounting holes on the mounting surface, using the template provided on the cover of the cardboard shipping package.
5. Using fasteners appropriate to your drive and mounting surface, securely attach the drive to the mounting surface using all 4 screws or bolts.

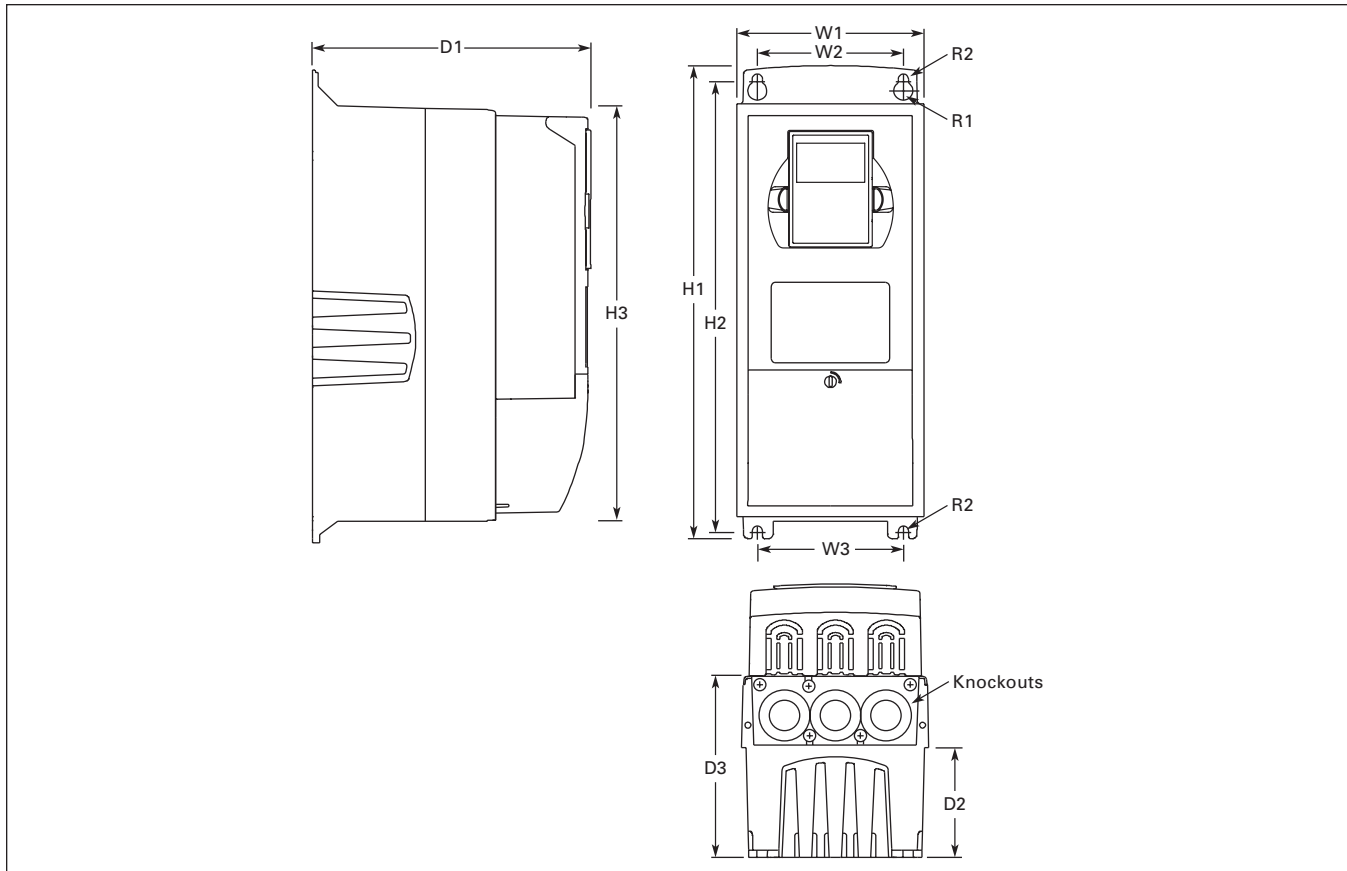

Figure 2-1: NEMA Type 1 and NEMA Type 12 SLX9000 Drive Dimensions, MF4 – MF6

Table 2-1: SLX9000 Drive Dimensions

Voltage	hp (I _H)	Approximate Dimensions in Inches (mm)											Wt. Lbs. (kg)	Knockouts @ Inches (mm) N1 (O.D.)
		H1	H2	H3	D1	D2	D3	W1	W2	W3	R1 dia.	R2 dia.		
Frame Size — MF4														
230	3/4 – 3	12.9	12.3	11.5	7.5	3.0	5.0	5.0	3.9	—	.5	.3	11.0	3 @ 1.1 (28)
480	1 – 5	(327)	(313)	(292)	(190)	(77)	(126)	(128)	(100)		(13)	(7)	(5)	
Frame Size — MF5														
230	5 – 7-1/2	16.5	16.0	15.3	8.4	3.9	5.8	5.6	3.9	—	.5	.3	17.9	2 @ 1.5 (37)
480	7-1/2 – 15	(419)	(406)	(389)	(214)	(100)	(148)	(143)	(100)		(13)	(7)	(8)	1 @ 1.1 (28)
Frame Size — MF6														
230	10 – 15	22.0	21.3	20.4	9.3	4.2	6.5	7.6	5.8	—	.6	.4	40.8	3 @ 1.5 (37)
480	20 – 30	(558)	(541)	(519)	(237)	(105)	(165)	(195)	(148)		(15.5)	(9)	(19)	
575	2 – 25													

October 2007

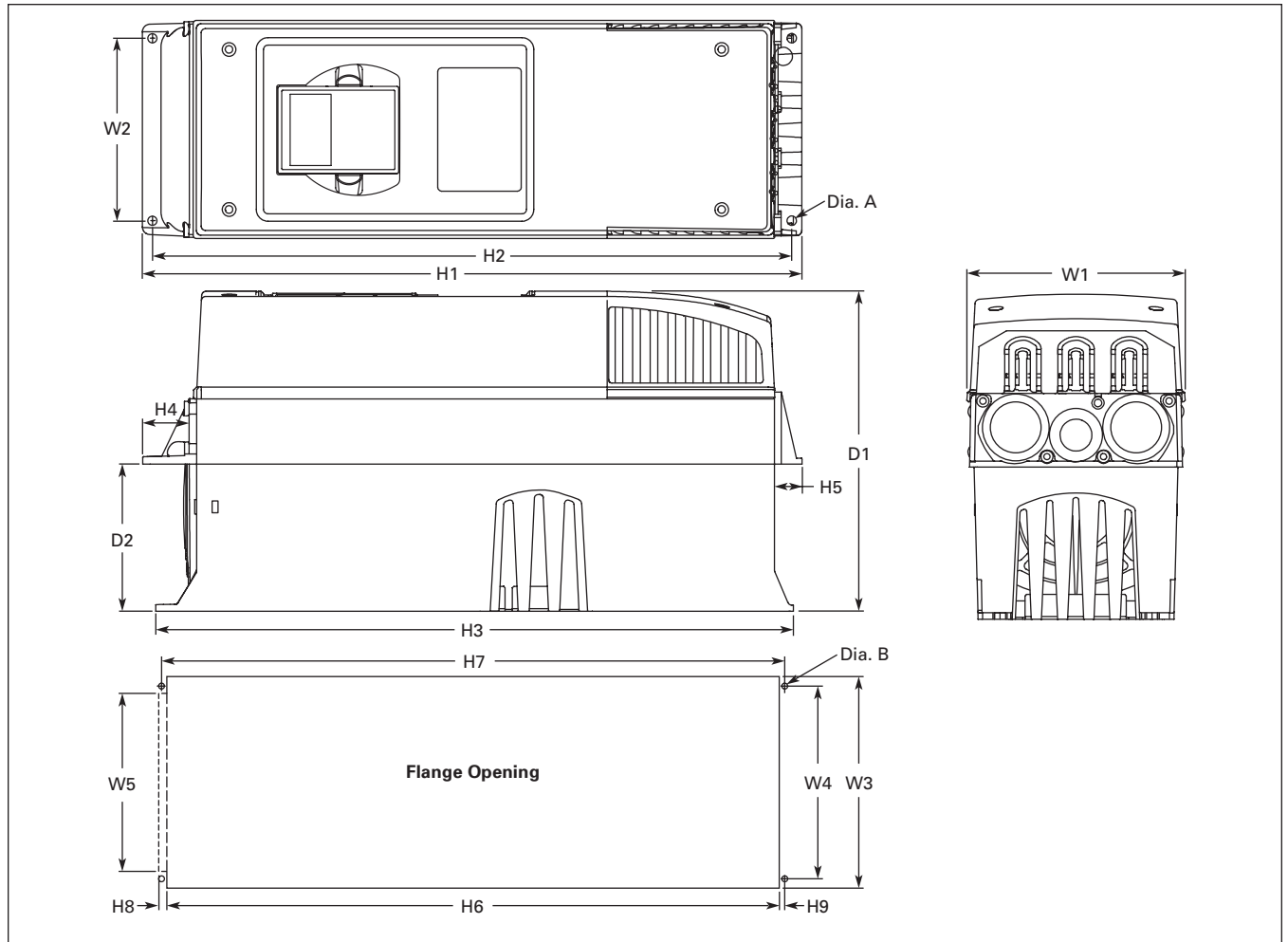

Figure 2-2: SLX9000 Dimensions, NEMA Type 1 and NEMA Type 12 with Flange Kit, MF4 – MF6

Table 2-2: Dimensions for SLX9000, MF4 – MF6 with Flange Kit

Voltage	hp (I _H)	Approximate Dimensions in Inches (mm)									
		W1	W2	H1	H2	H3	H4	H5	D1	D2	Dia. A
Frame Size — MF4											
230	3/4 – 3	5.0	4.5	13.3	12.8	12.9	1.2	.9	7.5	3.0	.3
480	1 – 5	(128)	(113)	(337)	(325)	(327)	(30)	(22)	(190)	(77)	(7)
Frame Size — MF5											
230	5 – 7-1/2	5.6	4.7	17.0	16.5	16.5	1.4	.7	8.4	3.9	.3
480	7-1/2 – 15	(143)	(120)	(434)	(420)	(419)	(36)	(18)	(214)	(100)	(7)
Frame Size — MF6											
230	10 – 15	7.7	6.7	22.0	21.6	22.0	1.2	.8	9.3	4.2	.3
480	20 – 30	(195)	(170)	(560)	(549)	(558)	(30)	(20)	(237)	(106)	(7)
575	2 – 25										

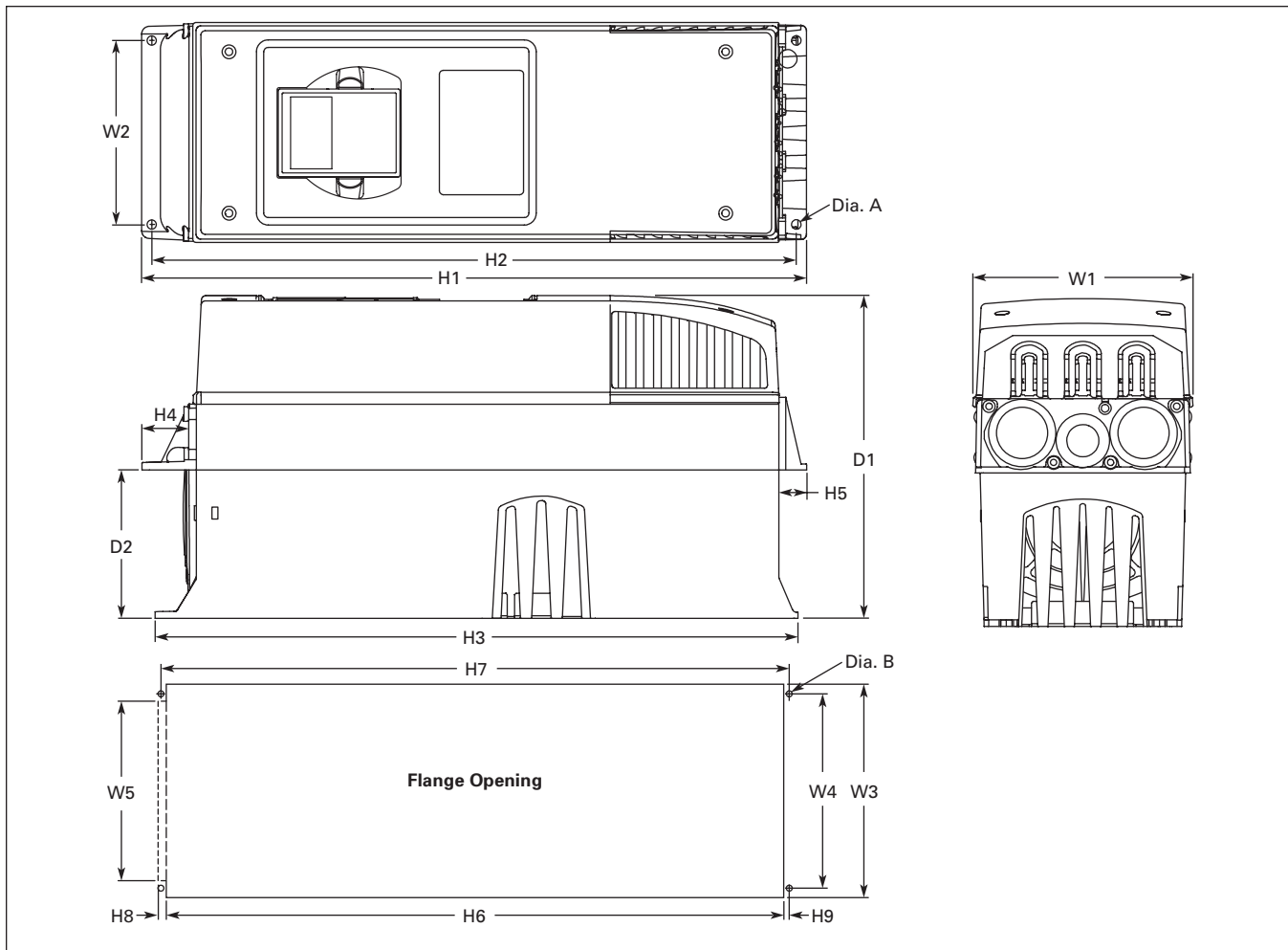

Figure 2-3: SLX9000 Dimensions, NEMA Type 1 and NEMA Type 12 with Flange Opening, MF4 – MF6

Table 2-3: Dimensions for the Flange Opening, MF4 – MF6

Voltage	hp (I _H)	Approximate Dimensions in Inches (mm)							
		W3	W4	W5	H6	H7	H8	H9	Dia. B
Frame Size — MF4									
230	3/4 – 3	4.8 (123)	4.5 (113)	—	12.4 (315)	12.8 (325)	—	.2 (5)	.3 (7)
480	1 – 5								
Frame Size — MF5									
230	5 – 7-1/2	5.3 (135)	4.7 (120)	—	16.2 (410)	16.5 (420)	—	.2 (5)	.3 (7)
480	7-1/2 – 15								
Frame Size — MF6									
230	10 – 15	7.3 (185)	6.7 (170)	6.2 (157)	21.2 (539)	21.6 (549)	.3 (7)	.2 (5)	.3 (7)
480	20 – 30								
575	2 – 25								

October 2007

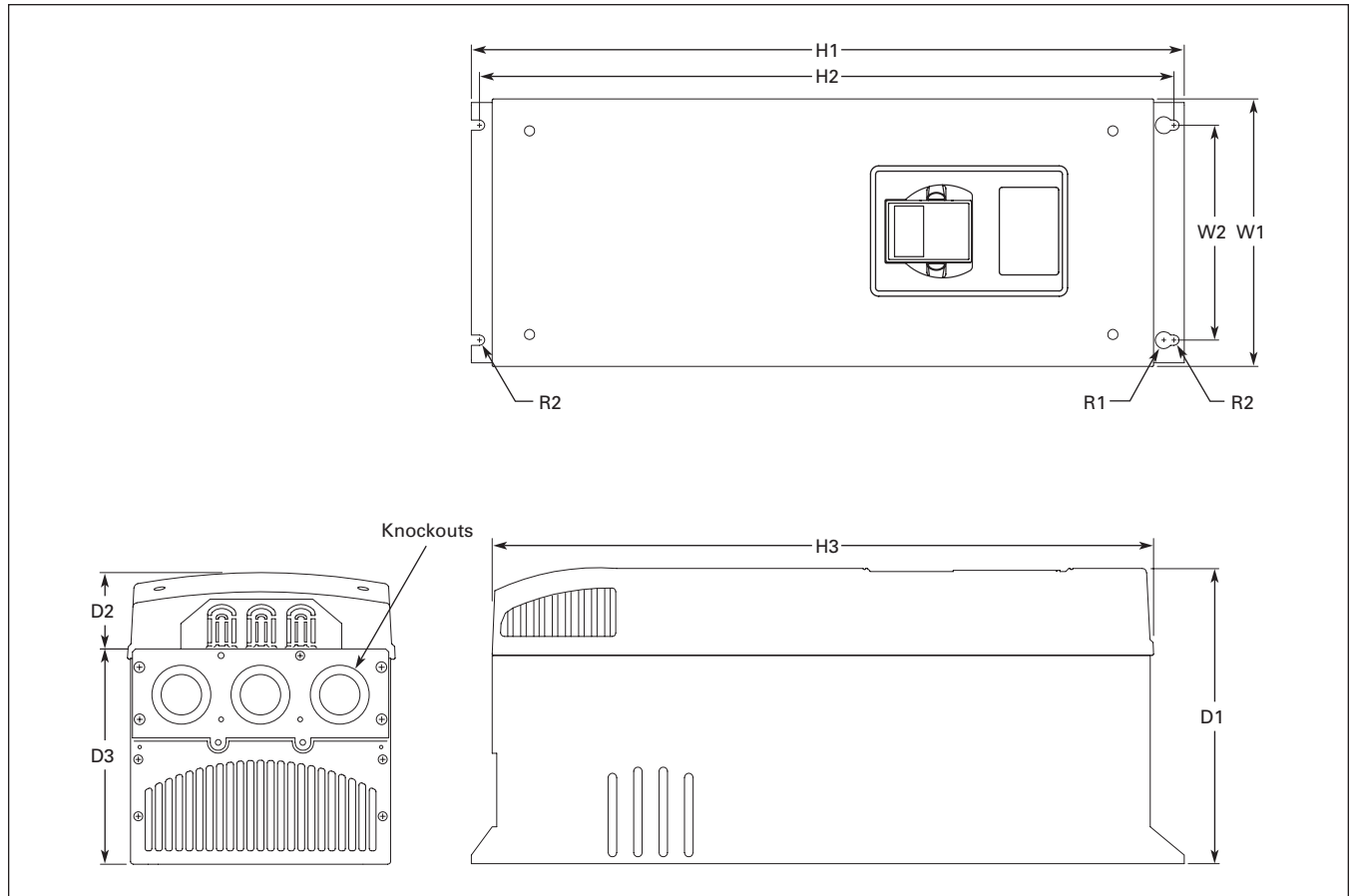

Figure 2-4: SLX9000 Dimensions, NEMA Type 1 and NEMA Type 12, FR7

Table 2-4: SLX9000 Dimensions, FR7

Voltage	hp (I _H)	H1	H2	H3	D1	D2	D3	W1	W2	R1 dia.	R2 dia.	Wt. lbs. (kg)	Knockouts @
													N1 (O.D.)
Frame Size — FR7													
230V	20 – 30	24.8 (630)	24.2 (614)	23.2 (590)	10.1 (257)	3.0 (77)	7.3 (184)	9.3 (237)	7.5 (190)	.7 (18)	.4 (9)	77.2 (35)	3 @ 1.5 (37)
480V	40 – 60												
575V	30 – 40												

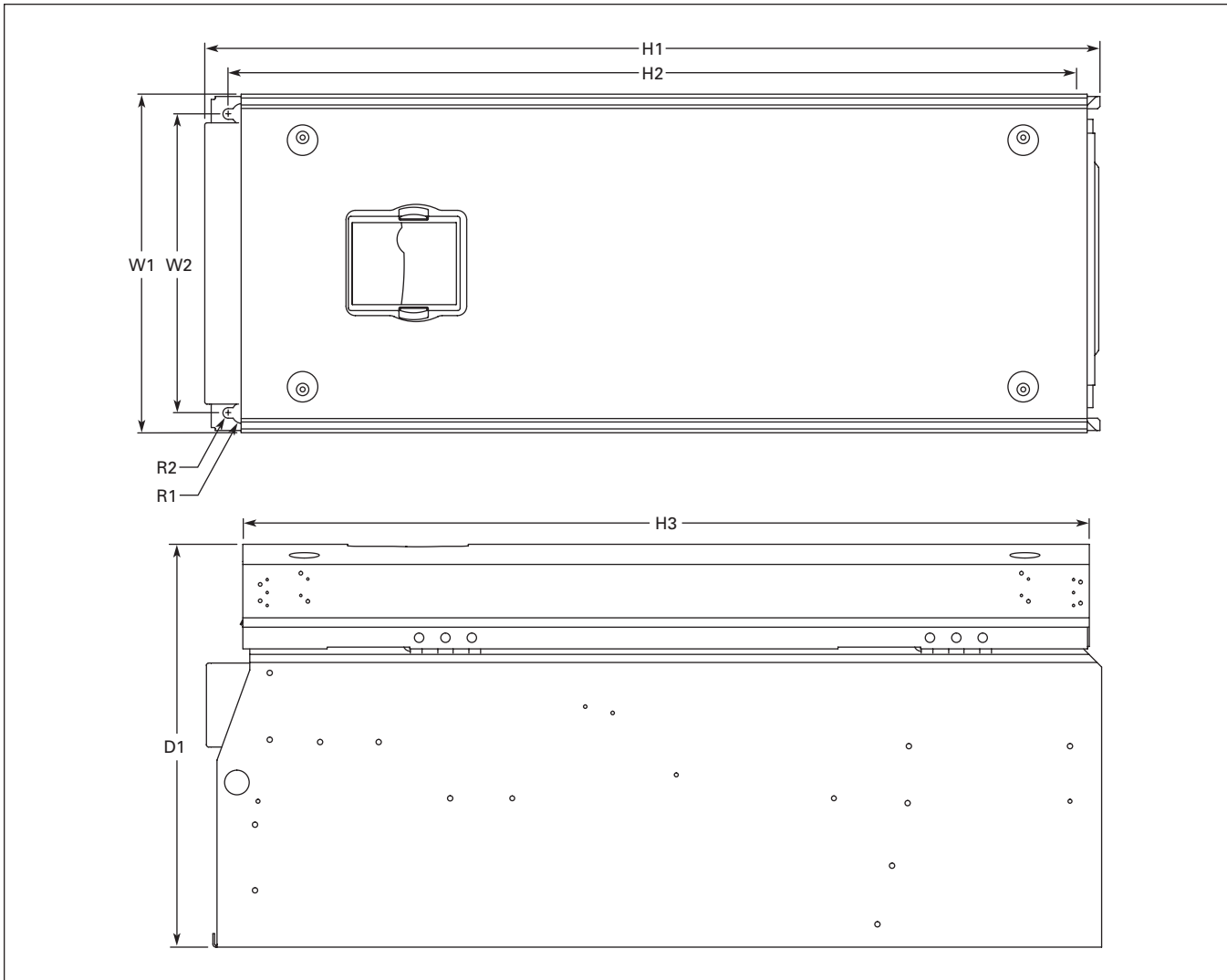

Figure 2-5: SLX9000 Dimensions, NEMA Type 1 and NEMA Type 12, FR8

Table 2-5: SLX9000 Dimensions, FR8

Voltage	hp (I _H)	Approximate Dimensions in Inches (mm)								Wt. lbs. (kg)
		D1	H1	H2	H3	W1	W2	R1 dia.	R2 dia.	
Frame Size — FR8										
460V	75	13.5	30.1	28.8	28.4	11.5	10	.7	.4	127
575V	50 – 75	(344)	(764)	(732)	(721)	(291)	(255)	(18)	(9)	(58)

October 2007

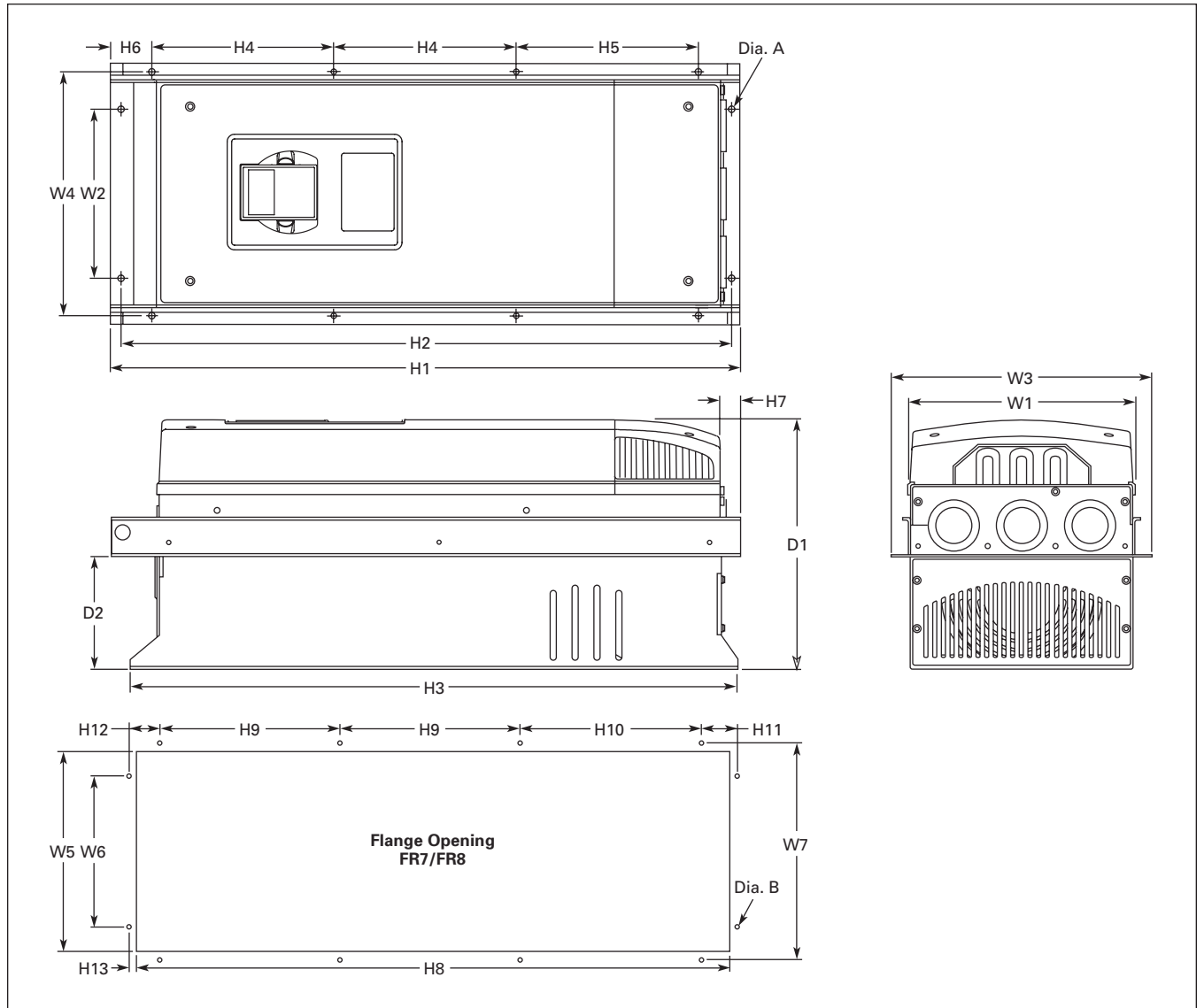

Figure 2-6: SLX9000 Dimensions, NEMA Types 1 and 12, FR7 and FR8 with Flange Kit

Table 2-6: SLX9000 Dimensions, NEMA Types 1 and 12, FR7 and FR8 with Flange Kit

Voltage	hp (I _H)	Approximate Dimensions in Inches (mm)													
		W1	W2	W3	W4	H1	H2	H3	H4	H5	H6	H7	D1	D2	Dia. A
Frame Size — FR7															
230	3/4 – 3	9.3	6.8	10.6	10.0	25.6	24.8	24.8	7.4	7.4	.9	.8	10.1	4.6	.3
480	1 – 5	(237)	(175)	(270)	(253)	(652)	(632)	(630)	(189)	(189)	(23)	(20)	(257)	(117)	(6)
Frame Size — FR8															
230	5 – 7-1/2	11.2	—	14.0	13.0	32.8	—	29.3	10.2	10.4	1.7	2.2	13.5	4.3	.4
480	7-1/2 – 15	(285)	—	(355)	(330)	(832)	—	(745)	(258)	(265)	(43)	(57)	(344)	(110)	(9)

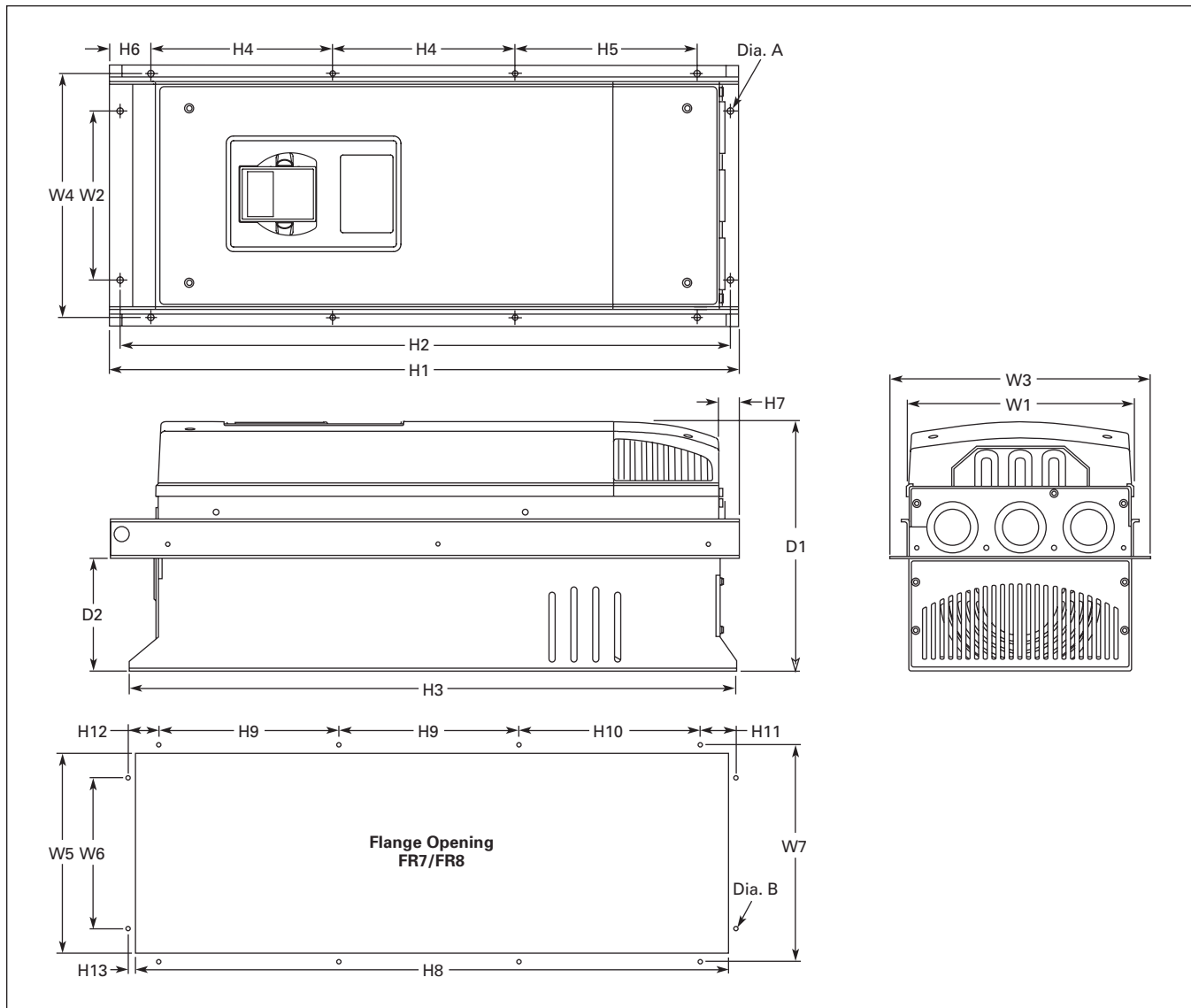

Figure 2-7: SLX9000 Dimensions, NEMA Types 1 and 12, FR7 and FR8 with Flange Opening

Table 2-7: SLX9000 Dimensions, NEMA Types 1 and 12, for the Flange Opening, FR7/FR8

Voltage	hp (l _H)	Approximate Dimensions in Inches (mm)									
		W5	W6	W7	H8	H9	H10	H11	H12	H13	Dia. B
Frame Size — FR7											
230	3/4 – 3	9.2	6.9	10.0	24.4	7.4	7.4	1.4	1.3	1.0	.3
480	1 – 5	(233)	(175)	(253)	(619)	(189)	(189)	(35)	(32)	(25)	(6)
Frame Size — FR8											
230	5 – 7-1/2	11.9	—	13.0	31.9	10.2	10.4	—	—	1.3	.4
480	7-1/2 – 15	(301)		(330)	(810)	(258)	(265)			(33)	(9)

October 2007

Cooling

Forced air flow cooling is used.

Enough free space needs to be left above and below the drive to ensure sufficient air circulation and cooling. You will find the required dimensions for free space in **Table 2-8**.

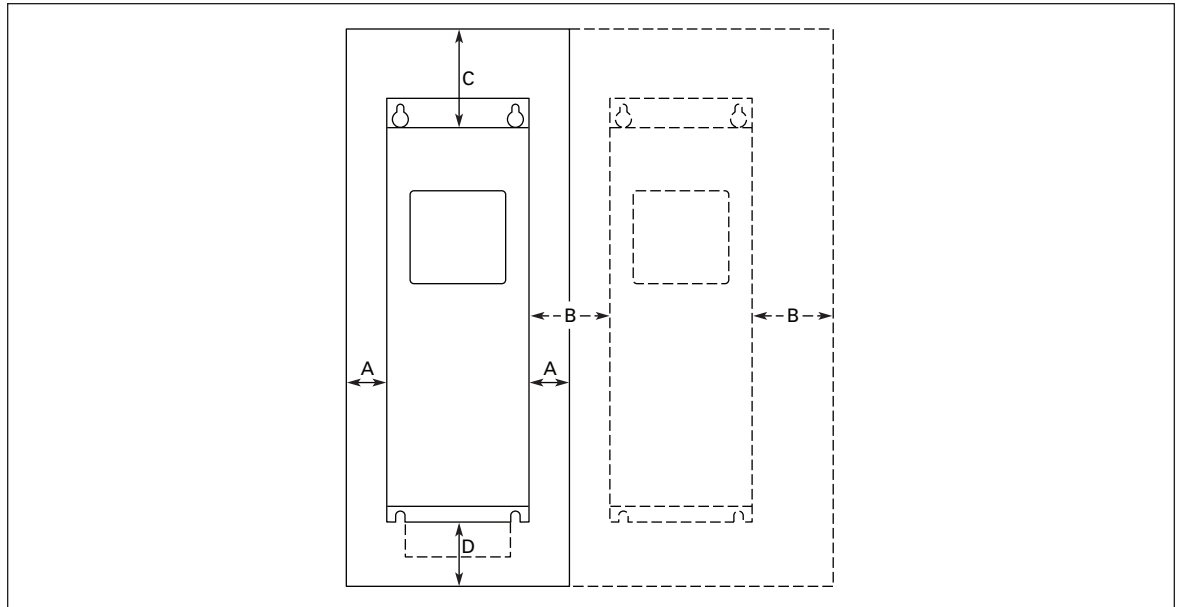

Figure 2-8: Installation Space

Table 2-8: Mounting Space Dimensions

Frame	Approximate Dimensions in Inches (mm)			
	A	B	C	D
MF4	.79 (20)	.79 (20)	3.94 (100)	1.97 (50)
MF5	.79 (20)	.79 (20)	4.72 (120)	2.36 (60)
MF6	1.18 (30)	.79 (20)	6.30 (160)	3.15 (80)
FR7	3.15 (80)	3.15 (80)	11.81 (300)	3.94 (100)
FR8	5.91 (150) ^①	3.15 (80)	11.81 (300)	7.87 (200)

^① Extra width is allowed to change the fan without disconnecting cables.

A = clearance around the drive (see also **B**)

B = clearance from one drive to another or distance to cabinet wall

C = free space above the drive

D = free space underneath the drive

Table 2-9: Required Cooling Air

Frame	Cooling Air Required (cfm)
MF4	41
MF5	112
MF6	250
FR7	250
FR8	383

Changing EMC Protection Class from H to T

The EMC protection class of SLX9000 drive frames MF4 – MF6 can be changed from **class H** to **class T** with a simple procedure presented in **Figure 2-9 – 2-10**.

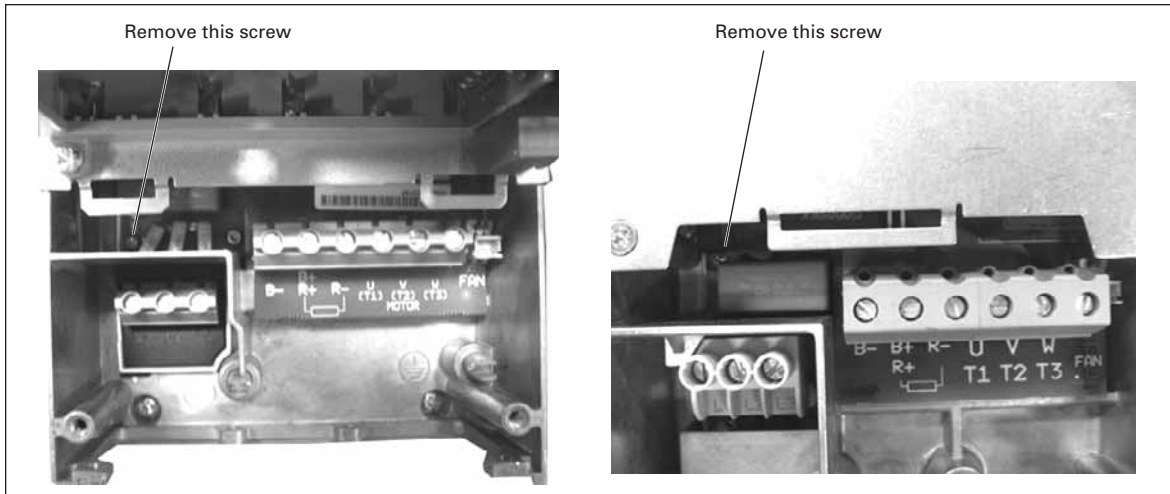

Figure 2-9: Changing of EMC Protection Class, MF4 (left) and MF5 (right), 460V

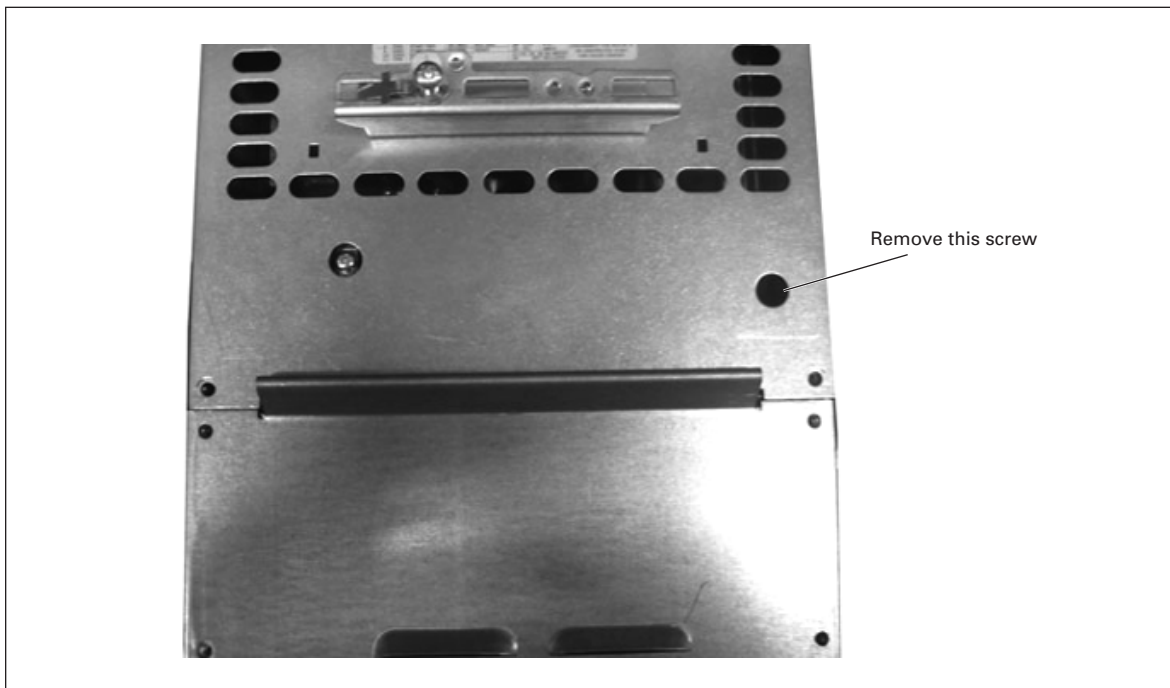

Figure 2-10: Changing of EMC Protection Class, MF6

Note: Do not attempt to change the EMC-level back to class H. Even if the procedure above is reversed, the drive will no longer fulfill the EMC requirements of class H!

October 2007

Chapter 3 — Power Wiring

Power Connections

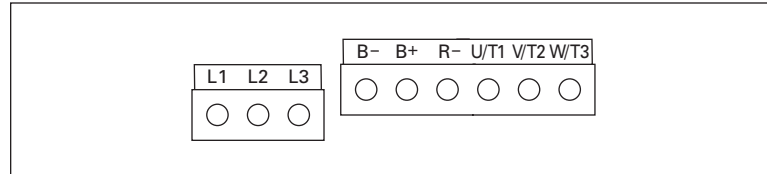

Figure 3-1: Power Connections, MF4 – MF6

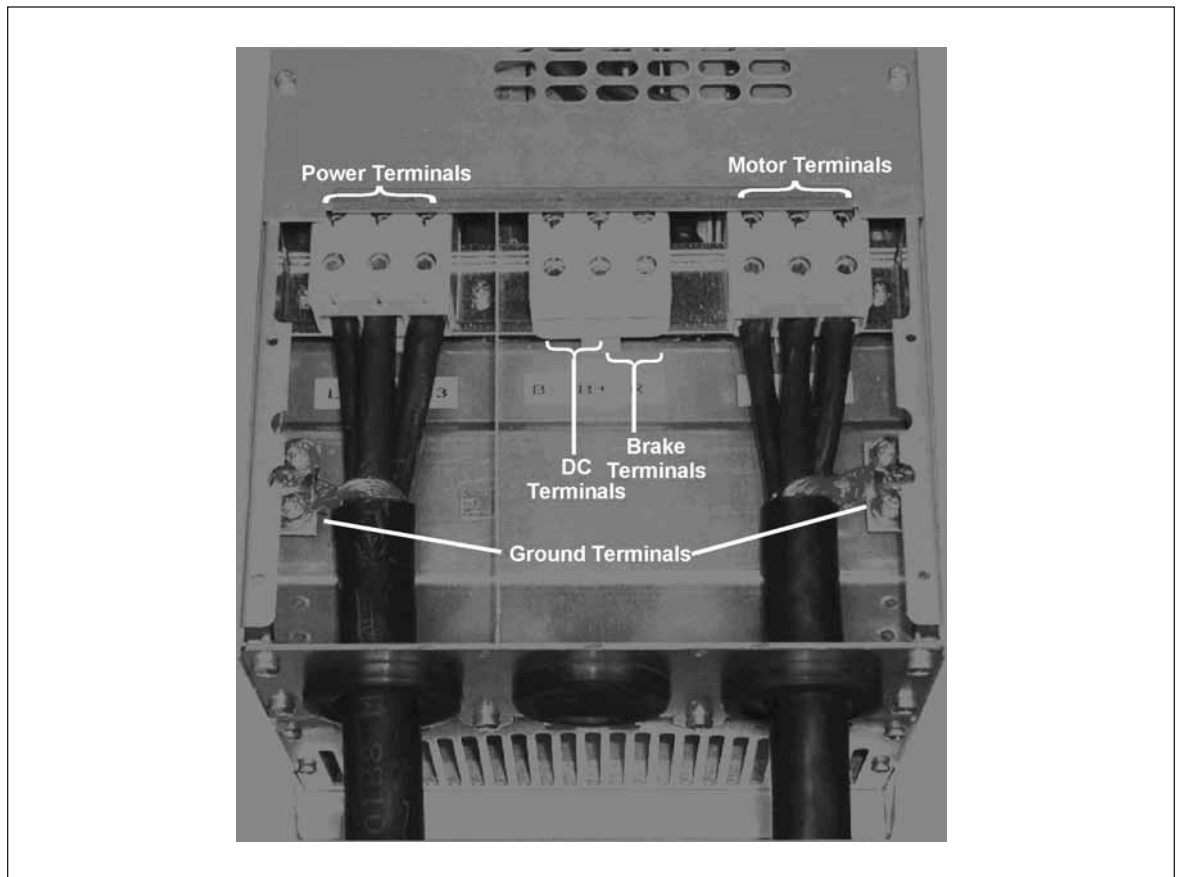

Figure 3-2: FR7 Power and Motor Wiring Terminals

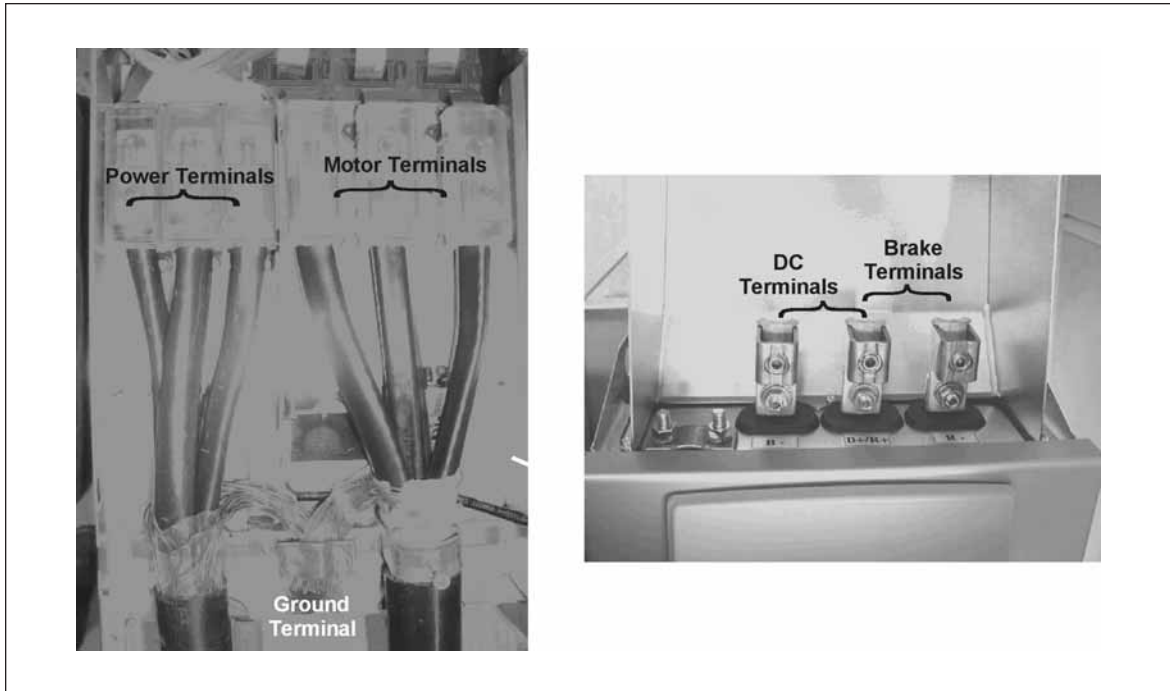

Figure 3-3: FR8 Power and Motor Wiring Terminals

Use cables with heat resistance of at least $+70^{\circ}\text{C}$. The cables and the fuses must be dimensioned according to **Tables 3-1** and **3-2**. Installation of cables according to UL regulations is found on **Page 3-15**.

The fuses also function as cable overload protection.

These instructions apply only to cases with one motor and one cable connection from the drive to the motor. In any other case, ask the factory for more information.

October 2007

Table 3-1: Cable Types Required to Meet Standards

Cable Type	1st Environment (Restricted Distribution) Level H/C	2nd Environment Level L	Level T	Level N
Mains Cable	1	1	1	1
Motor Cable	3 ^①	2	1	1
Control Cable	4	4	4	4

Level C = EN 61800-3+A11, 1st environment, unrestricted distribution EN 61000-6-3
Level H = EN 61800-3+A11, 1st environment, restricted distribution EN 61000-6-4
Level L = EN 61800-3, 2nd environment
Level T: Consult Eaton.
Level N: Consult Eaton.
 1 Power cable intended for fixed installation and the specific mains voltage. Shielded cable not required.
 2 Power cable equipped with concentric protection wire and intended for the specific mains voltage.
 3 Power cable equipped with compact low-impedance shield and intended for the specific mains voltage.
 4 Screened cable equipped with compact low-impedance shield.

^① 360° grounding of both motor and FC connection required to meet the standard.

Frames MF4 – MF6, FR7, FR8: A cable entry flange should be used when installing the motor cable at both ends in order to reach the EMC levels.

Note: The EMC requirements are fulfilled at factory defaults of switching frequencies (all frames).

Cable and Fuse Sizes

Use only copper wire with temperature rating of at least 75°C.

Table 3-2: Cable and Fuse Sizes – 230V Ratings

hp	Frame Size	I _l (A)	Fuse (A) ^②	Wire Size ^③		Terminal Size	
				Power	Ground	Power	Ground
1	MF4	4.8	10	14	14	12 – 16	14 – 16
1-1/2		6.6	10	14	14	12 – 16	14 – 16
2		7.8	10	14	14	12 – 16	14 – 16
3		11	15	12	14	12 – 16	14 – 16
5	MF5	17.5	20	10	10	8 – 16	8 – 16
7-1/2		25	30	8	8	8 – 18	8 – 16
10	MF6	31	40	8	8	1/0 – 14	2 – 10
15		48	60	4	6	1/0 – 14	2 – 10
20	FR7	61	80	2	6	1/0 – 14	2/0 – 10
25		72	100	2	6	1/0 – 14	2/0 – 10
30		87	110	1/0	4	1/0 – 14	2/0 – 10

^② UL recognized type RK.

^③ Based on a maximum environment of 104°F (40°C).

Table 3-3: Cable and Fuse Sizes – 480V Ratings

hp	Frame Size	I _L (A)	Fuse (A) ^①	Wire Size ^②		Terminal Size	
				Power	Ground	Power	Ground
1-1/2	MF4	3.3	10	14	14	12 – 16	14 – 16
2		4.3	10	14	14	12 – 16	14 – 16
3		5.6	10	14	14	12 – 16	14 – 16
5		7.6	10	14	14	12 – 16	14 – 16
7-1/2	MF5	12	15	12	12	8 – 16	8 – 16
10		16	20	10	10	8 – 16	8 – 16
15		23	30	8	8	8 – 16	8 – 16
20	MF6	31	35	8	8	1/0 – 14	2 – 10
25		38	50	6	8	1/0 – 14	2 – 10
30		46	60	4	6	1/0 – 14	2 – 10
40	FR7	61	80	2	6	1/0 – 14	2/0 – 10
50		72	100	2	6	1/0 – 14	2/0 – 10
60		87	110	1/0	4	1/0 – 14	2/0 – 10
75	FR8	105	125	2/0	2	4 – 3/0	3/0 – 4

^① UL recognized type RK.

^② Based on a maximum environment of 104°F (40°C).

Table 3-4: Cable and Fuse Sizes – 575V Ratings

hp	Frame Size	I _L (A)	Fuse (A) ^③	Wire Size ^④		Terminal Size	
				Power	Ground	Power	Ground
2	MF6	3.3	10	14	14	14 – 1/0	14 – 2
3		4.5	10	14	14	14 – 1/0	14 – 2
5		7.5	10	14	14	14 – 1/0	14 – 2
7-1/2		10	15	12	14	14 – 1/0	14 – 2
10		13.5	20	10	12	14 – 1/0	14 – 2
15	18	30	10	10	14 – 1/0	14 – 2	
20	22	35	8	8	14 – 1/0	14 – 2	
25	27	40	8	8	14 – 1/0	14 – 2	
30	FR7	34	50	6	8	14 – 1/0	10 – 1/0
40		41	60	4	6	14 – 1/0	10 – 1/0
50	FR8	52	80	2	6	4 – 3/0	4 – 3/0
60		62	100	1	6	4 – 3/0	4 – 3/0
75		80	125	1/0	6	4 – 3/0	4 – 3/0

^③ UL recognized type RK.

^④ Based on a maximum environment of 104°F (40°C).

October 2007

Mounting of Cable Accessories

Enclosed with your drive you have received a plastic bag containing components that are needed for the installation of the mains and motor cables in the drive.

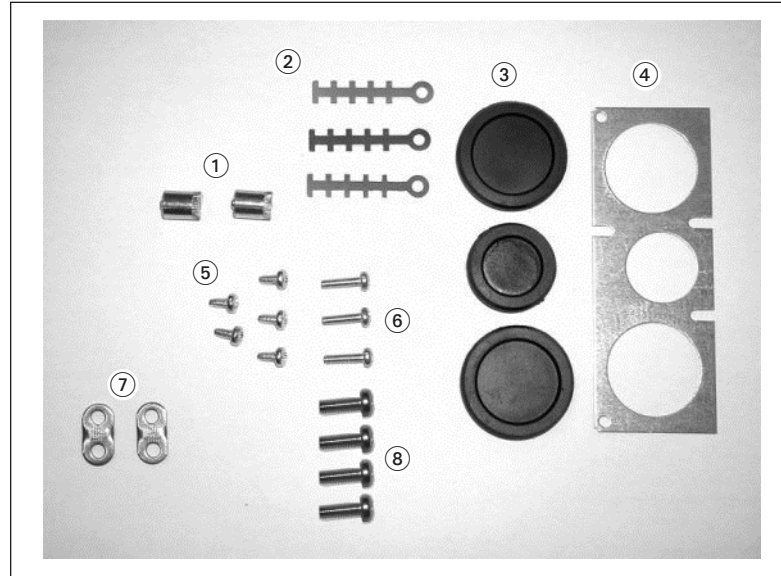



Figure 3-4: Cable Accessories

Components:

- | | | | |
|---|--|---|---|
| 1 | Grounding terminals (MF4, MF5) (2) | 5 | Screws, M4x10 (5) |
| 2 | Cable clamps (3) | 6 | Screws, M4x16 (3) |
| 3 | Rubber grommets (sizes vary from class to class) (3) | 7 | Grounding cable clamps (MF6, FR7) (2) (FR8) (1) |
| 4 | Cable entry gland (1) | 8 | Grounding screws M5x16 (MF6, FR7) (4) (FR8) (2) |

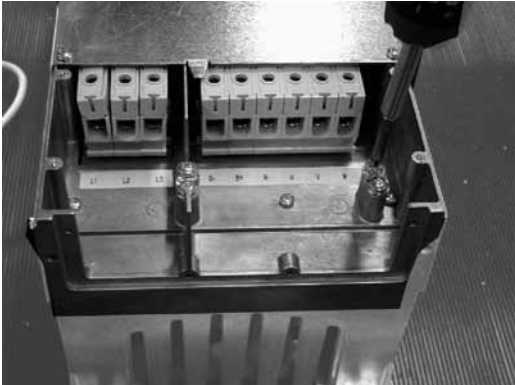

Note: The cable accessories installation kit for drives of protection class NEMA Type 12 includes all components except 4 and 5.

Table 3-5: Mounting Procedure

1	Make sure that the plastic bag you have received contains all necessary components.	
2	Open the cover of the drive.	
3	Remove the cable cover. Observe the places for: a) the grounding terminals (MF4/MF5)	
	b) the grounding cable clamps (MF6, FR7, FR8)	

October 2007

Table 3-5: Mounting Procedure (Continued)

<p>4</p>	<p>Re-install the cable cover. Mount the cable clamps with the three M4x16 screws as shown. Note that the location of the grounding bar in MF6, FR7 and FR8 is different from what is shown in the picture.</p>	
<p>5</p>	<p>Place the rubber grommets in the openings as shown.</p>	
<p>6</p>	<p>Fix the cable entry gland to the frame of the drive with the five M4x10 screws. Close the cover of the drive.</p>	

Installation Guidelines

To ensure proper wiring, use the following guidelines:

- Use heat-resistant copper cables only, +75°C or higher.
- The input line cable and line fuses must be sized in accordance with the rated input current of the unit. See **Tables 3-2 – 3-4**.
- Consistent with UL listing requirements, for maximum protection of the SLX9000 drive, UL recognized fuses type RK5 should be used for 480V and 230V ratings.
- If the motor temperature sensing is used for overload protection, the output cable size may be selected based on the motor specifications.
- If three or more shielded cables are used in parallel for the output on the larger units, every cable must have its own overload protection.
- Avoid placing the motor cables in long parallel lines with other cables.
- If the motor cables run in parallel with other cables, note the minimum distances between the motor cables and other cables given in **Table 3-6** below:

Table 3-6: Cable Spacings

Minimum Distance Between Cables in Feet (m)	Cable in Feet (m)
1 (0.3)	≤ 164 (50)
3.3 (1.0)	≤ 656 (200)

- The spacings of **Table 3-6** also apply between the motor cables and signal cables of other systems.
- The maximum length of the motor cables is as follows:
 - 1 – 2 hp, 230V units, 328 ft. (100m)
 - All other hp units, 984 ft. (300m)
- The motor cables should cross other cables at an angle of 90 degrees.
- If conduit is being used for wiring, use separate conduits for the input power wiring, the output power wiring, the signal wiring and the control wiring.

October 2007

Stripping Lengths of Motor and Mains Cables

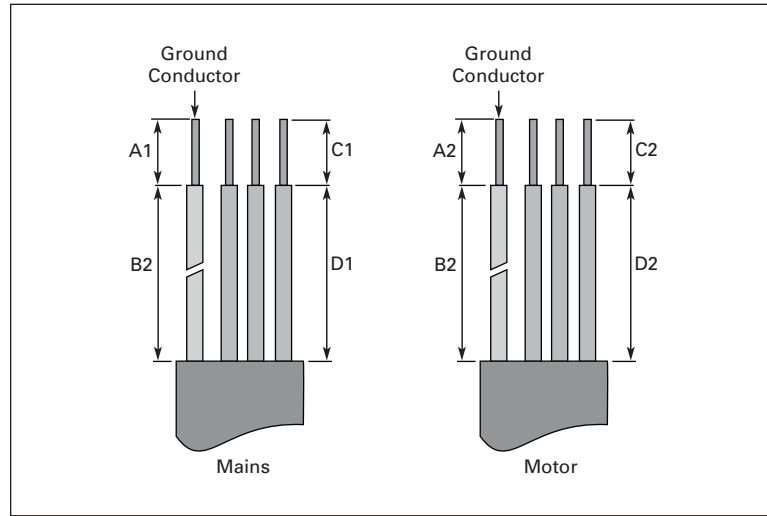

Figure 3-5: Stripping of Cables

Table 3-7: Cable Stripping Lengths

Frame	Approximate Dimensions in Inches (mm)							
	A1	B1	C1	D1	A2	B2	C2	D2
MF4	.59 (15)	1.38 (35)	.39 (10)	.79 (20)	.28 (7)	1.97 (50)	.28 (7)	1.38 (35)
MF5	.79 (20)	1.57 (40)	.39 (10)	1.18 (30)	.79 (20)	2.36 (60)	.39 (10)	1.57 (40)
MF6	.79 (20)	3.54 (90)	.59 (15)	2.36 (60)	.79 (20)	3.54 (90)	.59 (15)	2.36 (60)
FR7	.98 (25)	4.72 (120)	.98 (25)	4.72 (120)	.98 (25)	4.72 (120)	.98 (25)	4.72 (120)
FR8	1.10 (28)	9.45 (240)	1.10 (28)	9.45 (240)	1.10 (28)	9.45 (240)	1.10 (28)	9.45 (240)

Installation of Cables to SLX9000, MF4 – MF6



Figure 3-6: SLX9000, MF4

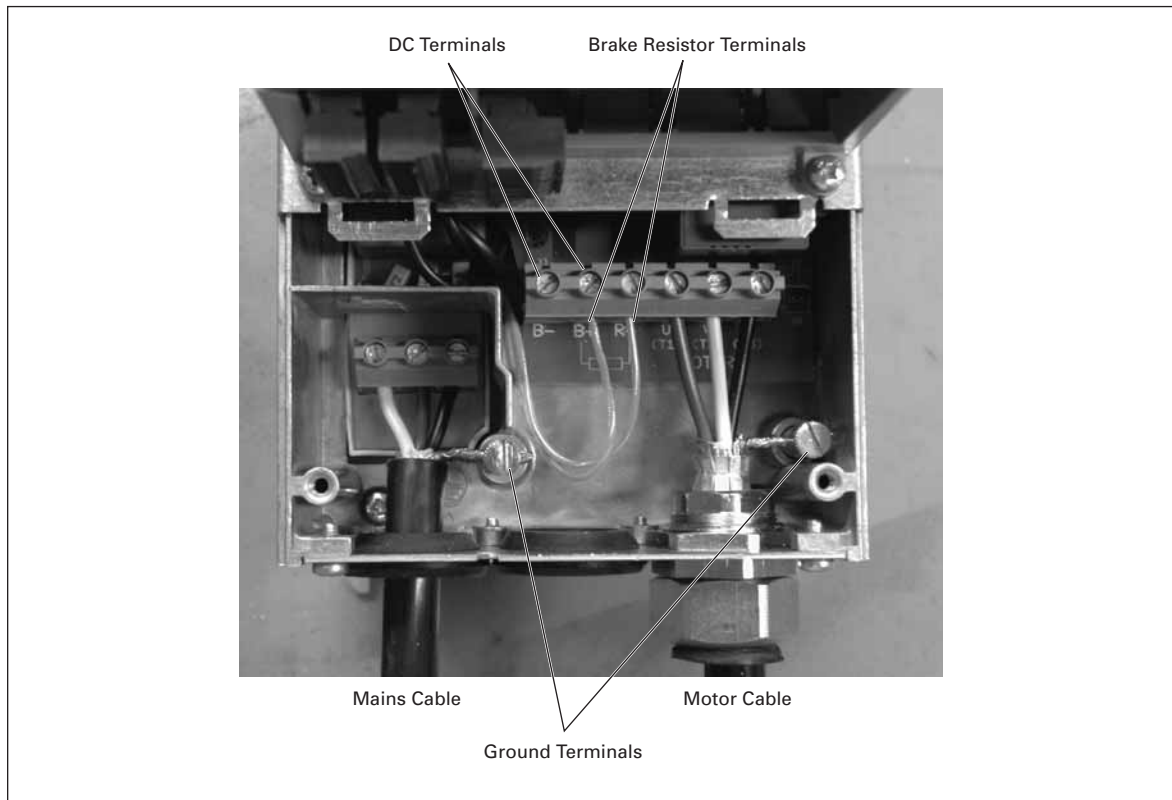

Figure 3-7: Cable Installation in SLX9000, MF4

October 2007



Figure 3-8: SLX9000, MF5

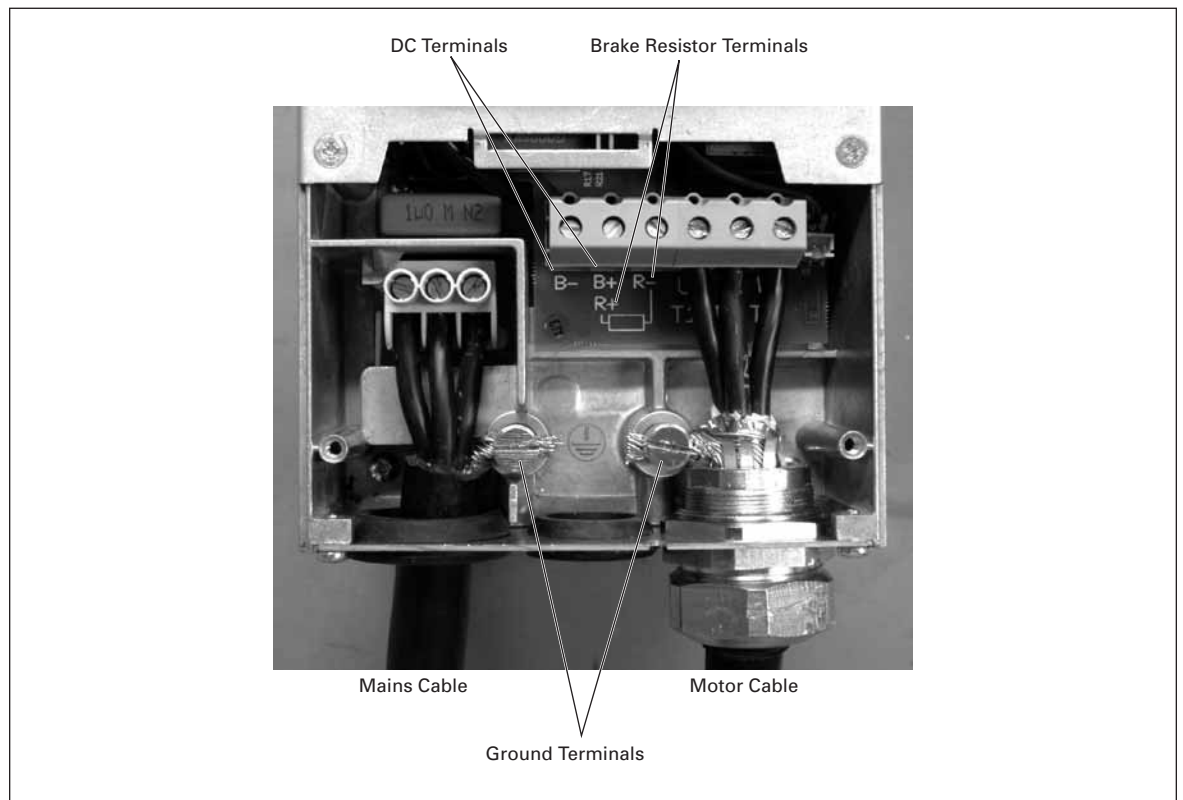

Figure 3-9: Cable Installation in SLX9000, MF5



Figure 3-10: SLX9000, MF6

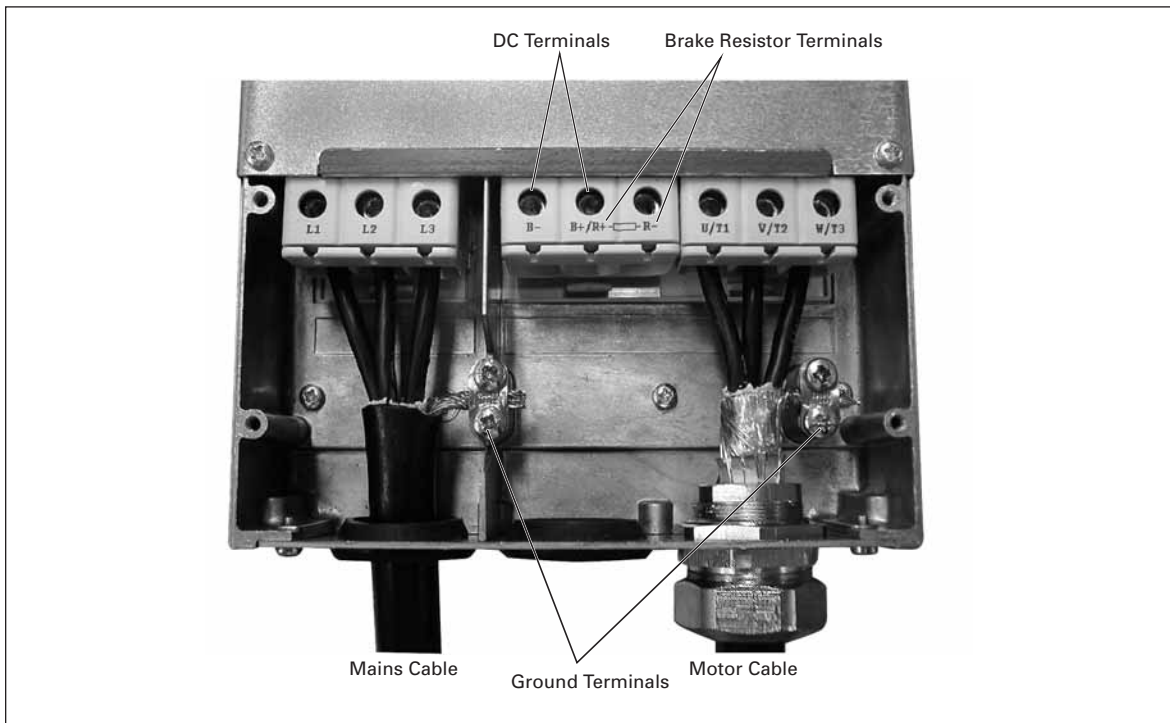

Figure 3-11: Cable Installation in SLX9000, MF6

October 2007

Installation of Cables to SLX9000, FR7



Figure 3-12: SLX9000, FR7

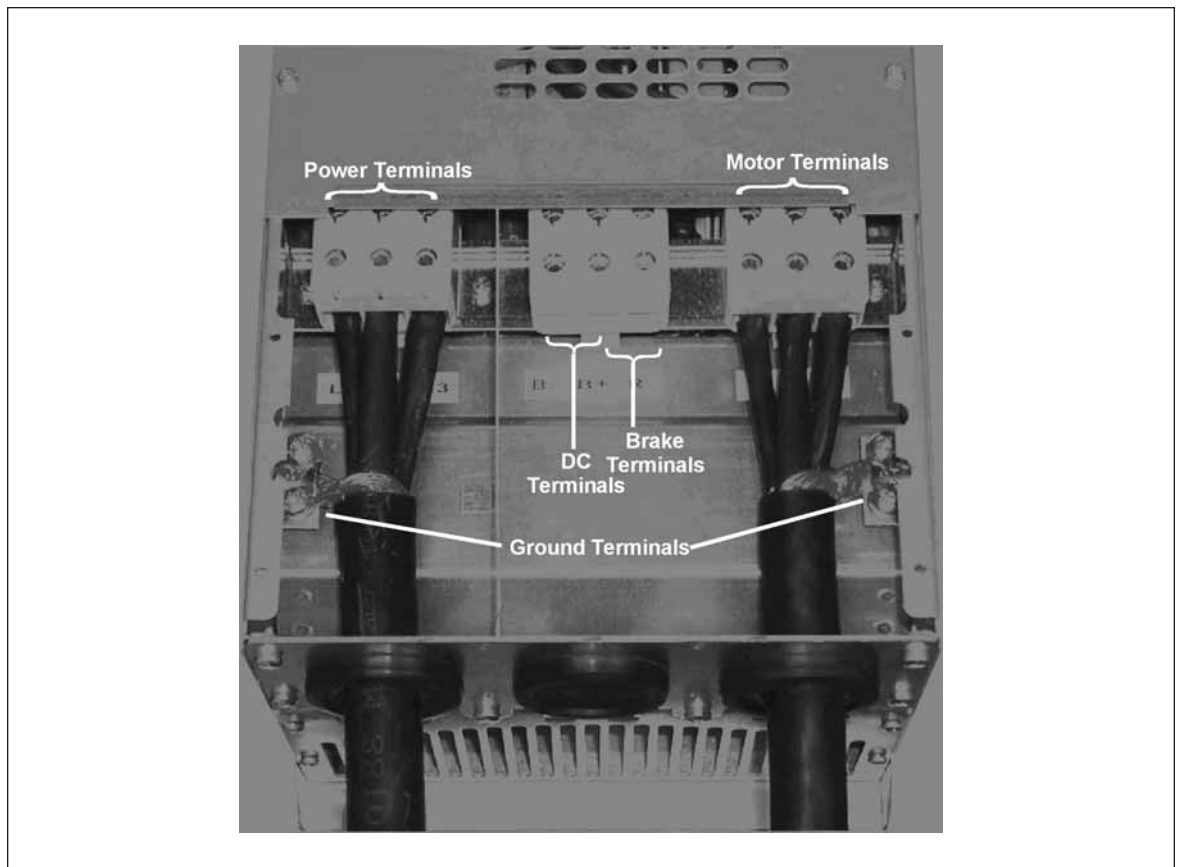

Figure 3-13: Cable Installation in SLX9000, FR7

Installation of Cables to SLX9000, FR8



Figure 3-14: SLX9000, FR8

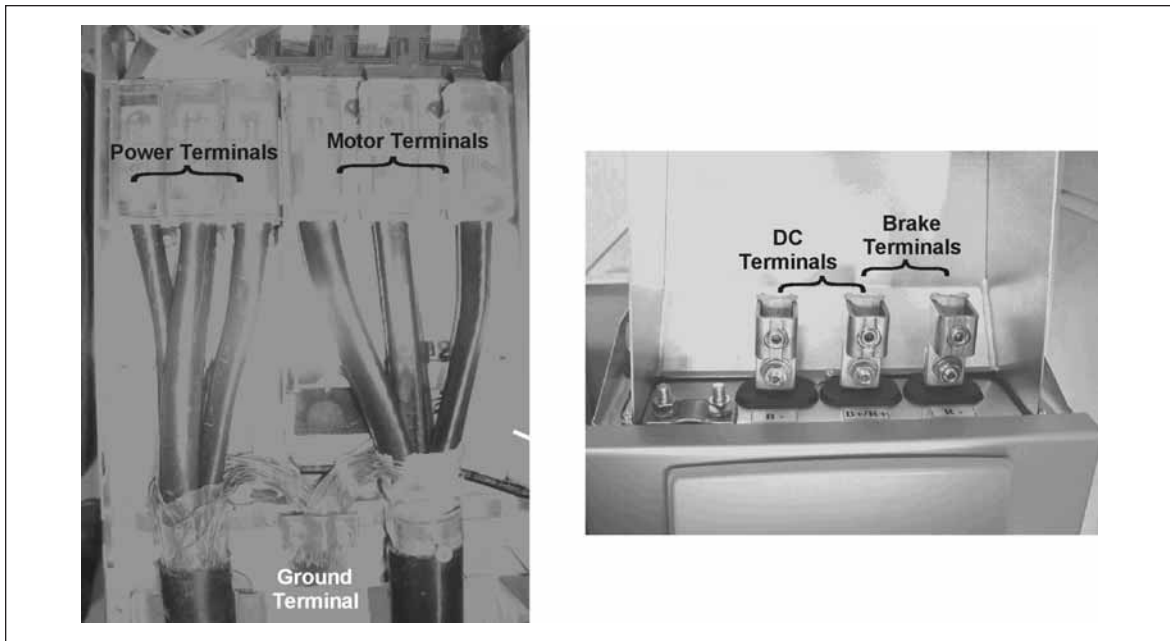

Figure 3-15: Cable Installation in SLX9000, FR8

October 2007

Cable Installation and the UL Standards

To meet the UL (Underwriters Laboratories) regulations, a UL-approved copper cable with a minimum heat-resistance of +60/75°C must be used.

The tightening torques of the terminals are given in **Table 3-8**.

Table 3-8: Tightening Torques of Terminals

Frame	Tightening Torque (Nm)	Tightening Torque in-lbs.
MF4	.5 – .6	4 – 5
MF5	1.2 – 1.5	10 – 13
MF6	4	35
FR7	10	85
FR8	40/22 ^①	340/187 ^①

^① The isolation standoff of the bus bar will not withstand the listed tightening torque. Use a wrench to apply a counter torque when tightening.

Cable and Motor Insulation Checks

1. Motor cable insulation checks

Disconnect the motor cable from terminals U, V and W of the drive and from the motor. Measure the insulation resistance of the motor cable between each phase conductor as well as between each phase conductor and the protective ground conductor.

The insulation resistance must be >1MΩ.

2. Mains cable insulation checks

Disconnect the mains cable from terminals L1, L2 and L3 of the drive and from the mains. Measure the insulation resistance of the mains cable between each phase conductor as well as between each phase conductor and the protective ground conductor.

The insulation resistance must be >1MΩ.

3. Motor insulation checks

Disconnect the motor cable from the motor and open the bridging connections in the motor connection box. Measure the insulation resistance of each motor winding. The measurement voltage must equal at least the motor nominal voltage but not exceed 1000V. The insulation resistance must be >1MΩ.

October 2007

Chapter 4 — Control Wiring

Control Unit

MF4 – MF6 460V

In frames MF4 – MF6 there are two option board connectors SLOT D and SLOT E (see **Figure 4-1**). Newest software supports hardware with two board slots. Also older software versions can be used, but they will not support hardware with two board slots.

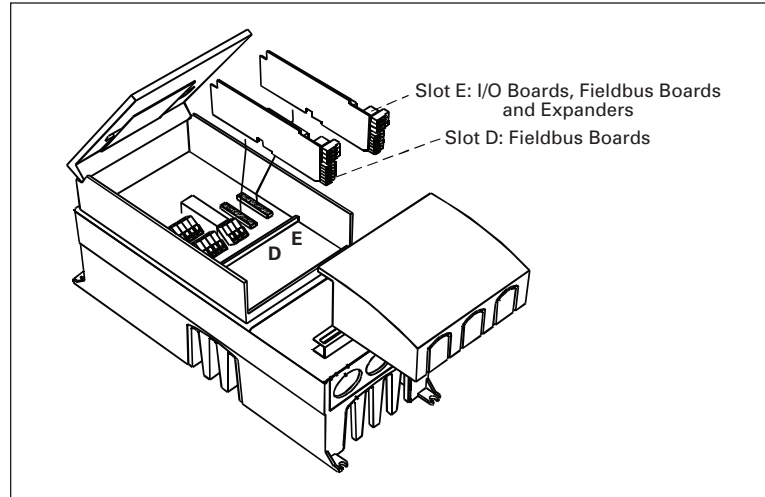

Figure 4-1: Option Board Slots D and E in Frames MF4 – MF6

460V only.

Allowed Option Boards in MF4 – MF6

See below for the allowed option boards in the two slots on MF4 – MF6 drives.

SLOT D	C3	C4	C6	C7	CI	CJ									
SLOT E	AA	AI	B1	B2	B4	B5	B9	C2	C3	C4	C6	C7	C8	CI	CJ

When two option boards are used, the one in slot E has to be OPTAI or OPTAA. Do not use two OPTB_ or OPTC_ boards. Also, combinations of OPTB_ and OPTC_ boards are prohibited.

See descriptions for OPTAA and OPTAI option boards in **Appendixes B and C**.

All 230V, FR7 – FR8 460V and All 575V

The control unit of FR7 and FR8 drives consists of the control board and various option boards that plug into the five slot connectors (A to E) of the control board.

Galvanic isolation of the control terminals is provided as follows:

- The control connections are isolated from power, and the GND terminals are permanently connected to ground.
- The digital inputs are galvanically isolated from the I/O ground.
- The relay outputs are double-isolated from each other at 300V AC.

Option Board General Information

The FR7 and FR8 drives can accommodate a wide selection of *expander* and *adapter option boards* to customize the drive for your application needs.

The drive's control unit is designed to accept a total of five option boards. Option boards are available for normal analog and digital inputs and outputs, communication and additional application-specific hardware.

The factory-installed standard option board configuration includes an A9 I/O board and an A2 relay output board, which are installed in slots A and B. For information on additional option boards, see the *9000X Series Drives Option Board User Manual*.

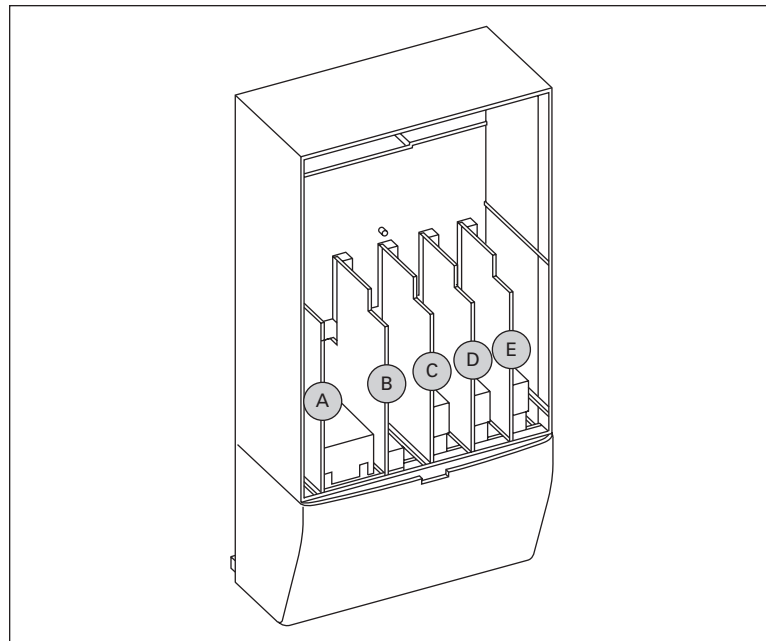

Figure 4-2: Option Board Slots

All 230V, FR7 – FR8 480V and All 575V.

Control Connections

MF4 – MF6 460V

The basic control connections for MF4 – MF6 are shown on **Page 4-3**.

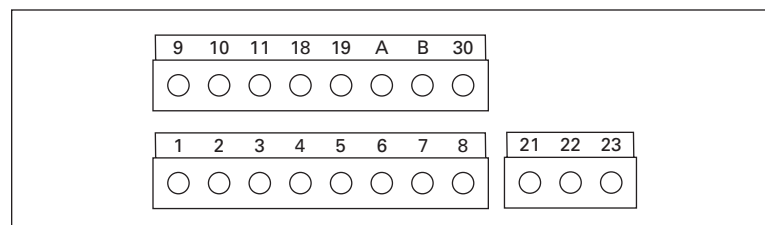

Figure 4-3: Control Connections, MF4 – MF6 460V

October 2007

Table 4-1: Multi-Control Application Default Input/Output Configuration, MF4 – MF6 460V

Terminal	Signal	Description
Reference potentiometer 1 – 10 kΩ		
1	+10 V _{ref}	Reference output Voltage for potentiometer, etc.
2	AI1+	Analog input, voltage range 0 – 10V DC Voltage input frequency reference
3	AI1-	I/O Ground Ground for reference and controls
4	AI2+	Analog input, current range 0 – 20 mA Current input frequency reference
5	AI2-/GND	
6	+24V	Control voltage output Voltage for switches, etc. max .1A
7	GND	I/O ground Ground for reference and controls
8	DIN1	Start forward (programmable) Contact closed = start forward
9	DIN2	Start reverse (programmable) Contact closed = start reverse
10	DIN3	Multi-step speed selection 1 (programmable) Contact closed = multi-step speed
11	GND	I/O ground Ground for reference and controls
18	AO1+	Output frequency Analog output Programmable Range 0 – 20 mA, R _L max. 500Ω
19	AO1-	
A	RS-485	Serial bus Differential receiver/transmitter
B	RS-485	Serial bus Differential receiver/transmitter
30	+24V	24V auxiliary input voltage Control power supply backup
21	RO1	Relay output 1 FAULT
22	RO1	
23	RO1	

Table 4-2: AI1 Configuration, When Programmed as DIN4, MF4 – MF6 460V

Terminal	Signal	Description
1	+10 V _{ref}	Reference output Voltage for potentiometer, etc.
2	AI1+ or DIN4	Analog input, voltage range 0 – 10V DC Voltage input frequency reference (MF2 – MF3) Voltage/current input frequency reference (MF4 – MF6) Can be programmed as DIN4
3	AI1-	I/O Ground Ground for reference and controls
4	AI2+	Analog input, current range 0 – 10V DC or current range 0 – 20 mA Voltage or current input frequency reference
5	AI2-/GND	
6	+24V	Control voltage output
7	GND	I/O ground Ground for reference and controls

Reference potentiometer
1 – 10 kΩ

Table 4-3: Default I/O Configuration, All 230V, FR7 – FR8 460V and All 575V

Terminal	Signal	Description
OPTA1		
1	+10V _{ref}	Reference output Voltage for potentiometer, etc.
2	AI1+	Analog input, voltage range 0 – 10V DC Voltage input frequency reference
3	AI1-	I/O Ground Ground for reference and controls
4	AI2+	Analog input, current range 0 – 20 mA Current input frequency reference
5	AI2-	
6	+24V ●	Control voltage output Voltage for switches. etc. max 0.1A
7 ●	GND	I/O ground Ground for reference and controls
8	DIN1	Start forward Contact closed = start forward
9	DIN2	Start reverse Contact closed = start reverse
10	DIN3	External fault input (programmable) Contact open = no fault Contact closed = fault
11	CMA	Common for DIN1 – DIN3 Connect to GND or +24V
12	+24V ●	Control voltage output Voltage for switches (see #6)
13 ●	GND	I/O ground Ground for reference and controls
14	DIN4	Multi-step speed select 1 DIN4 DIN5 Frequency ref. Open Open Ref. U _{in} Closed Open Multi-step ref.1 Open Closed Multi-step ref.2 Closed Closed RefMax
15	DIN5	
16	DIN6	
17	CMB	
18	AO1+	Output frequency Analog output Programmable Range 0 – 20 mA/R _L , max. 500Ω
19 ●	AO1-	
20	DO1	Digital output READY Programmable Open collector, I ≤ 50 mA, U ≤ 48V DC
OPTA2		
21	RO1	Relay output 1 RUN
22	RO1	
23	RO1	
24	RO2	Relay output 2 FAULT
25	RO2	
26	RO2	

October 2007

Table 4-4: Control Input/Output Terminal Signals, MF4 – MF6 460V

Terminal	Signal	Description
1	+10 V _{ref}	Reference voltage Maximum current 10 mA
2	AI1+	Analog input, voltage (MF4 and larger: voltage or current) MF4 – MF6: Selection V or mA with jumper block X8 (see Page 4-3): Default: 0 – 10V (R _i = 200 kΩ) 0 – 20 mA (R _i = 250W)
3	AI1-	Analog input common Differential input if not connected to ground; Allows ±20V differential mode voltage to GND
4	AI2+	Analog input, voltage or current Selection V or mA with jumper block X13 (MF4 – MF6) Default: 0 – 20mA (R _i = 250 Ω) 0 – 10V (R _i = 200 kΩ)
5	AI2-	Analog input common Differential input; Allows ±20V differential mode voltage to GND
6	24 V _{out}	24V auxiliary output voltage ±10%, maximum current 100 mA
7	GND	I/O ground Ground for reference and controls
8	DIN1	Digital input 1
9	DIN2	Digital input 2
10	DIN3	Digital input 3
11	GND	I/O ground Ground for reference and controls
18	AO1+	Analog signal (+output)
19	AO1-/GND	Analog output common Output signal range: Current 0(4) – 20 mA, R _L max 500Ω or
A	RS-485	Serial bus Differential receiver/transmitter, bus impedance 120Ω
B	RS-485	Serial bus Differential receiver/transmitter, bus impedance 120Ω
30	+24V	24V auxiliary input voltage Control power supply backup
21	RO1/1	 Relay output 1 Switching capacity: 24V DC/8A 250V AC/8A 125V DC/.4A Relay output terminals are galvanically isolated from the I/O ground
22	RO1/2	
23	RO1/3	

Table 4-5: Option Board A9 Terminal Descriptions, All 230V, FR7 – FR8 460V and All 575V

Terminal	Signal	Description and Parameter Reference
1	+10 V _{ref}	Reference voltage Maximum current 10 mA
2	AI1+	Analog input, voltage
3	GND	Analog input common Default: 0 – +10V (R _i = 200 kΩ) -10V to +10V (joystick control) 0 – 20 mA (R _i = 250 Ω) <i>Select V or mA with jumper block X1</i> Differential input if not connected to ground; allows ±20V differential mode voltage to GND
4	AI2+	Analog input
5	GND/AI2-	Analog input common Default: 0 – 20 mA (R _i = 250 Ω) 0 – +10V (R _i = 200 kΩ) -10V to +10V (joystick control) <i>Select V or mA with jumper block X2</i> Differential input if not connected to ground; allows ±20V differential mode voltage to GND
6	24 V _{out}	24V control voltage (bi-directional) ±15%, 250 mA (all boards total); 150 mA (max. current from single board); Can be used as external power backup for the control (and fieldbus); Galvanically connected to terminal #12
7	GND	I/O ground Ground for reference and controls; Galvanically connected to terminals #13, 19
8	DIA1	Digital input 1
9	DIA2	Digital input 2
10	DIA3	Digital input 3
11	CMA	Digital input common A for DIN1, DIN2 and DIN3 R _i = min. 5 kΩ Must be connected to GND or 24V of I/O terminal or to external 24V or GND. Selection with jumper block X3.
12	24 V _{out}	24V control voltage (bi-directional) Same as terminal #6; Galvanically connected to terminal #6
13	GND	I/O ground Same as terminal #7; Galvanically connected to terminals #7 & 19
14	DIB4	Digital input 4
15	DIB5	Digital input 5
16	DIB6	Digital input 6
17	CMB	Digital input common B for DIN4, DIN5 and DIN6 R _i = min. 5 kΩ Must be connected to GND or 24V of I/O terminal or to external 24V or GND. Select with jumper block X3.
18	A01+	Analog signal (+output) Output signal range: 0 – 10V default Current: 0(4) – 20 mA, RL max 500 Ω or Voltage: 0 – 10V, RL >1 kΩ Selection with jumper block X6.
19	A01-	Analog output common Maximum V _{in} = 48V DC; Galvanically connected to terminals #7, 13
20	DO1	Digital output1 Open collector, Maximum current = 50 mA

October 2007

Table 4-6: Option Board A2 Terminal Descriptions, All 230V, FR7 – FR8 460V and All 575V

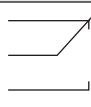
Terminal		Signal	Technical Information
21	RO1/1	Normally Closed (NC)	Switching Capacity: 24V DC / 8A 250V AC / 8A 125V DC / 0.4A Min Switching Load: 5V/10 mA Continuous Capacity: <2 Arms
22	RO1/2	Common	
23	RO1/3	Normally Open (NO)	
24	RO2/1	Normally Closed (NC)	Switching Capacity: 24V DC / 8A 250V AC / 8A 125V DC / 0.4A Min Switching Load: 5V/10 mA Continuous Capacity: <2 Arms
25	RO2/2	Common	
26	RO2/3	Normally Open (NO)	

Jumper Selections on SLX9000 Basic Board

The user is able to customize the functions of the drive to better suit an application by selecting certain positions for the jumpers on the SLX9000 board. The positions of the jumpers determine the signal type of analog input (terminal #2) and whether the termination resistor RS-485 is used or not.

The following figures present the jumper selections of SLX9000 drives:

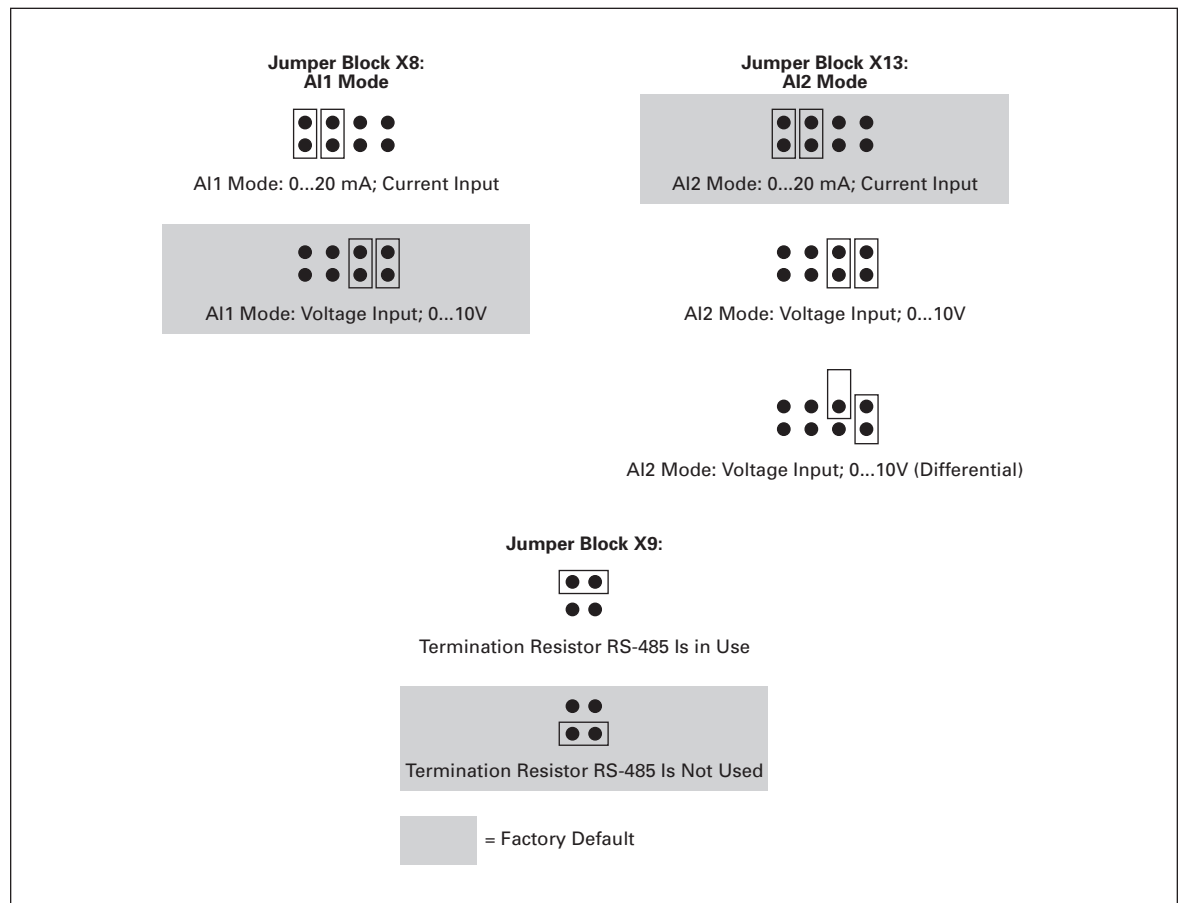

Figure 4-4: Jumper Selection for SLX9000, MF4 – MF6

⚠ CAUTION

Check the correct positions of the jumpers. Running the motor with signal settings different from the jumper positions will not harm the drive but may damage the motor.

Note: If you change the AI signal content also remember to change the corresponding parameters (S6.9.1, 6.9.2) in System Menu.

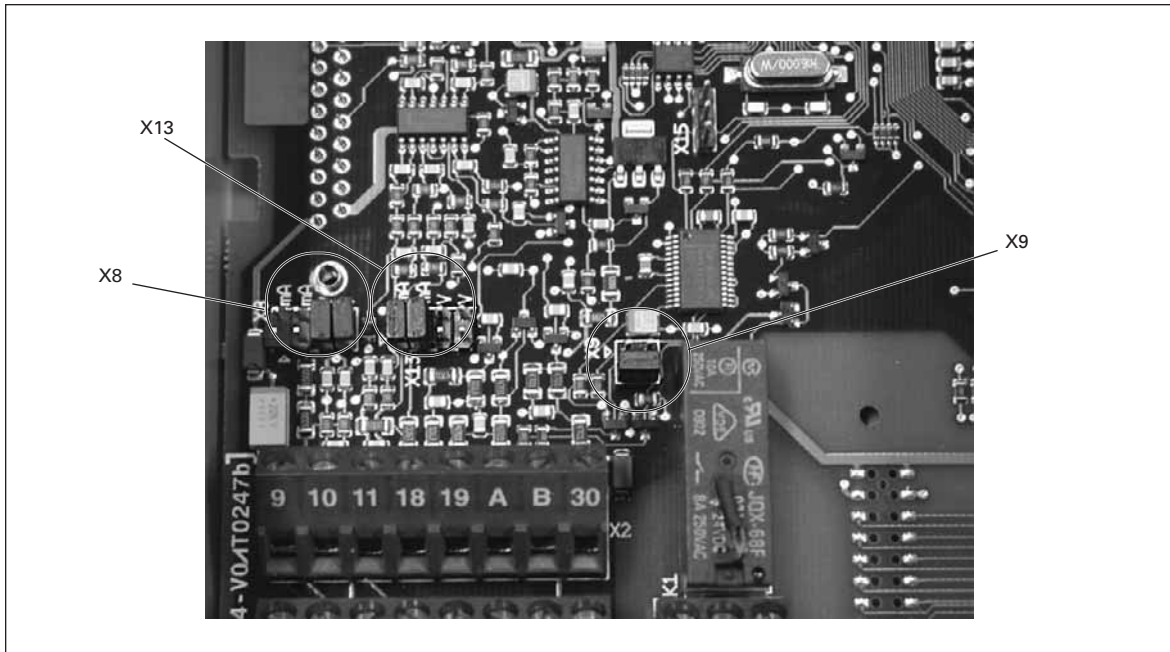

Figure 4-5: Location of Jumper Blocks in the Control Board of MF4 – MF6, 460V

October 2007

Motor Thermistor (PTC) Connection

There are three ways to connect a PTC resistor to SLX9000.

1. With optional board OPTAI (recommended method).

SLX9000 drive equipped with OPTAI fulfills IEC 664 if the motor thermistor is insulated (= effective double insulation).

2. With optional board OPTB2.

SLX9000 drive equipped with OPTB2 fulfills IEC 664 if the motor thermistor is insulated (= effective double insulation).

3. With the digital input (DIN3) of SLX9000 drive.

The DIN3 is galvanically connected to other I/Os of SLX9000. This is why reinforced or double insulation of the thermistor (IEC 664) is absolutely required outside the drive (in the motor or between the motor and the drive).

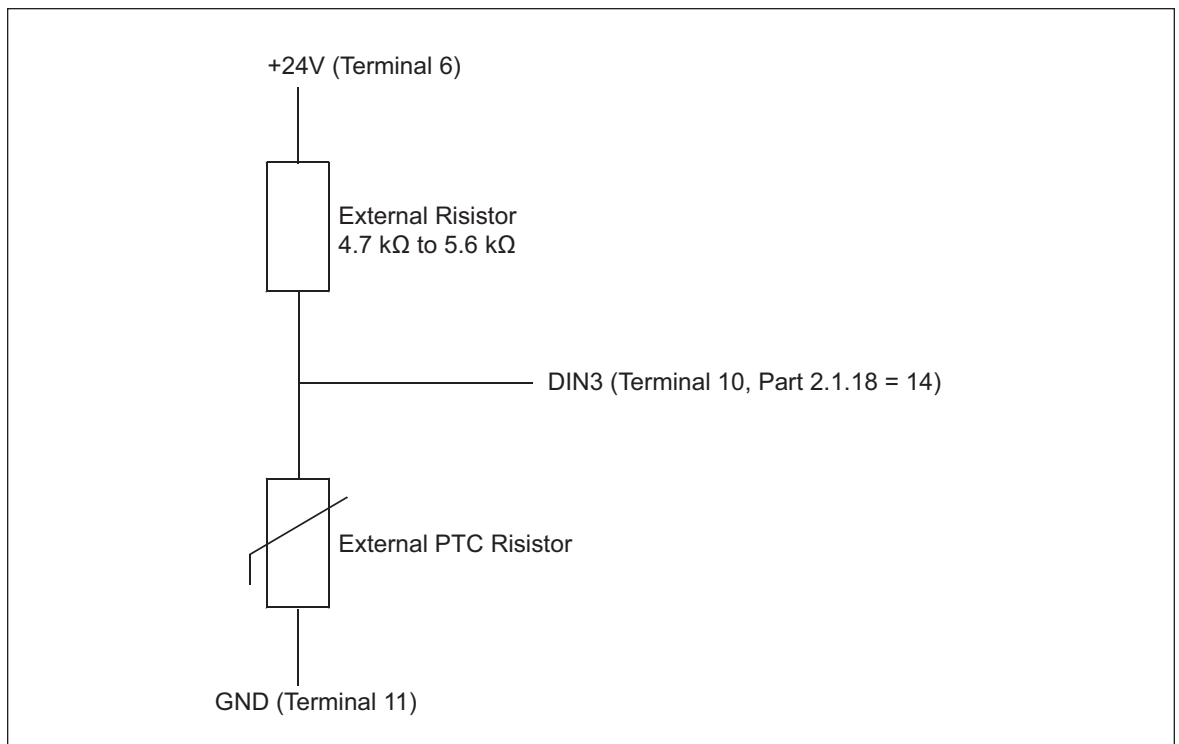

Figure 4-6: Motor Thermistor (PTC) Connection

Note: The drive trips when PTC impedance exceeds 4.7 kΩ.

We strongly recommend the use of OPTAI or OPTB2 board for motor thermistor connection.

⚠ WARNING

If the motor thermistor is connected to DIN3, the instructions above **must be** followed, otherwise a serious safety hazard may result from the connection.

October 2007

Chapter 5 — Menu Information

Keypad Operation

The control keypad is the link between the SLX9000 drive and the user. The control keypad features an alphanumeric display with seven indicators for the Run status (RUN, counterclockwise, clockwise, READY, STOP, ALARM, FAULT) and three indicators for the control place (I/O term/Keypad/BusComm).

The control information, i.e. the menu number, the displayed value and the numeric information are represented with numeric symbols.

The drive is operable through the seven pushbuttons of the control keypad. Furthermore, the buttons can be used in setting parameters and monitoring values.

The keypad is detachable and isolated from the input line potential.

Indicators on the Keypad Display

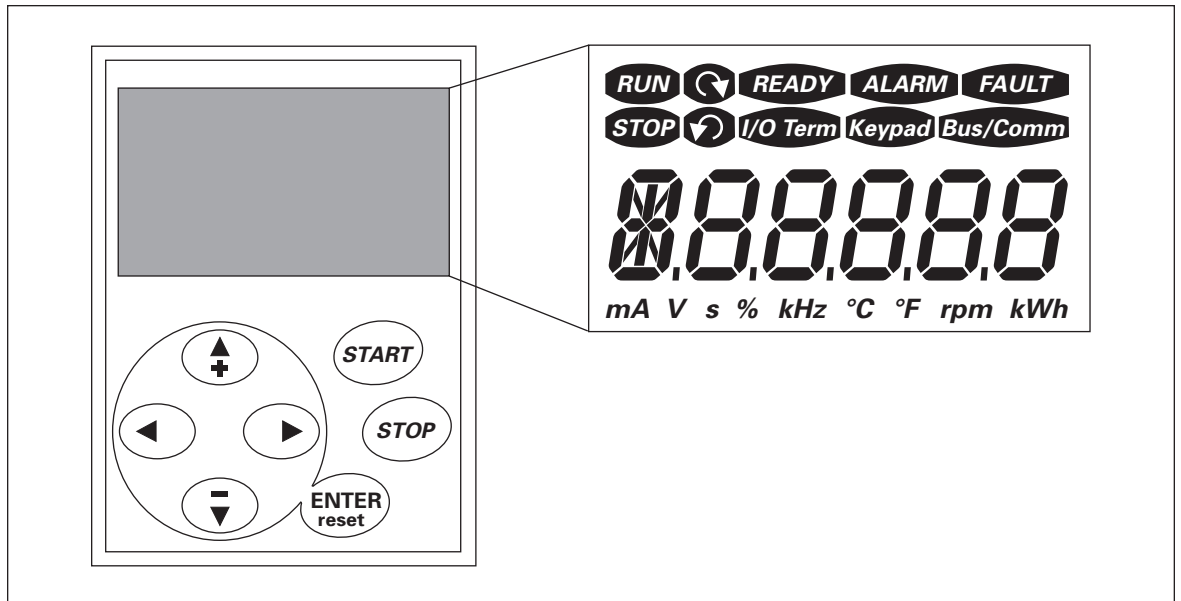







Figure 5-1: Control Keypad and Drive Status Indications

Drive Status Indicators

The drive status symbols tell the user the status of the motor and the drive.



Table 5-1: Drive Status Indicators

Indicator	Description
	RUN Motor is running; Blinks when the stop command has been given but the frequency is still ramping down.
	Indicates the direction of motor rotation.
	STOP Indicates that the drive is not running.
	READY Lights up when AC power is on. In case of a fault, the symbol will not light up.
	ALARM Indicates that the drive is running outside a certain limit and a warning is given.
	FAULT Indicates that unsafe operating conditions were encountered due to which the drive was stopped.

Control Place Indicators

The symbols I/O term, Keypad and Bus/Comm (see **Table 5-2**) indicate the choice of control place made in the Keypad control menu (M3) (see **Table 5-6**).

Table 5-2: Control Place Indicators

Indicator	Description
	I/O Terminal I/O terminals are selected as the control place i.e. START/STOP commands or reference values etc. are given through the I/O terminals.
	Keypad Control keypad is selected as the control place i.e. the motor can be started or stopped, or its reference values etc. altered from the keypad.
	Bus/Comm The drive is controlled through a fieldbus.

Numeric Indicators

The numeric indications provide the user with information on present location in the keypad menu structure as well as with information related to the operation of the drive.

October 2007

Keypad Pushbuttons

The SLX9000 seven-segment control keypad features seven pushbuttons that are used for the control of the DRIVE (and motor) and parameter setting.

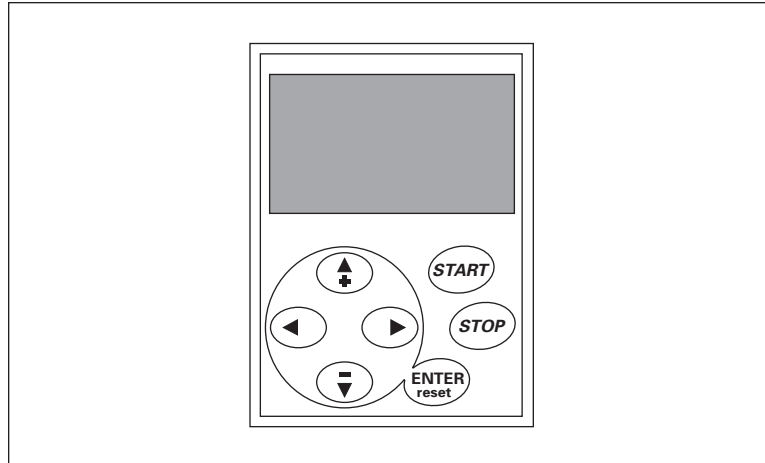

Figure 5-2: Keypad Pushbuttons

Table 5-3: Button Descriptions

Indicator	Description
	There are two operations integrated in this button. The button operates mainly as RESET button except in the parameter edit mode. The button operation is shortly described below. The ENTER button serves for: 1. confirmation of selections 2. fault history reset (2 – 3 seconds) RESET is used to reset active faults. Note: The motor may start immediately after resetting the faults.
	Browser Button Up Browse the main menu and the pages of different submenus. Edit values.
	Browser Button Down Browse the main menu and the pages of different submenus. Edit values.
	Menu Button Left Move backward in menu. Move cursor left (in parameter menu). Exit edit mode. Press for 2 to 3 seconds to return to main menu.
	Menu Button Right Move forward in menu. Move cursor right (in parameter menu). Enter edit mode.
	START Button Pressing this button starts the motor if the keypad is the active control place. See Page 5-10 .
	STOP Button Pressing this button stops the motor (unless disabled by parameter P3.4). See Page 5-10 . STOP button also serves for activating the Start-Up Wizard (see Page 6-4).

Menu Navigation

The data on the control keypad are arranged in menus and submenus. The menus are used for the display and editing of measurement and control signals, parameter settings (see **Page 5-8**) and reference value (see **Page 5-11**) and fault displays (see **Page 5-11**).

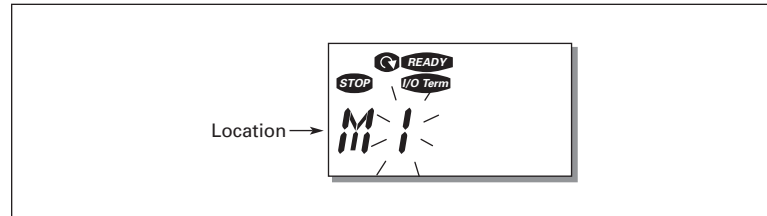

Figure 5-3: Keypad Display Data

The first menu level consists of menus M1 to E7 and is called the Main Menu. The user can navigate in the main menu with the Browser buttons up and down. The desired submenu can be entered from the main menu with the Menu buttons. When there still are pages to enter under the currently displayed menu or page, the last digit of the figure blinks and you can reach the next menu level by pressing Menu Button Right.

The control keypad navigation chart is shown in **Figure 5-4**. Please note that menu **M1** is located in the lower left corner. From there you will be able to navigate your way up to the desired menu using the menu and browser buttons.

You will find more detailed descriptions of the menus later in this chapter.

October 2007

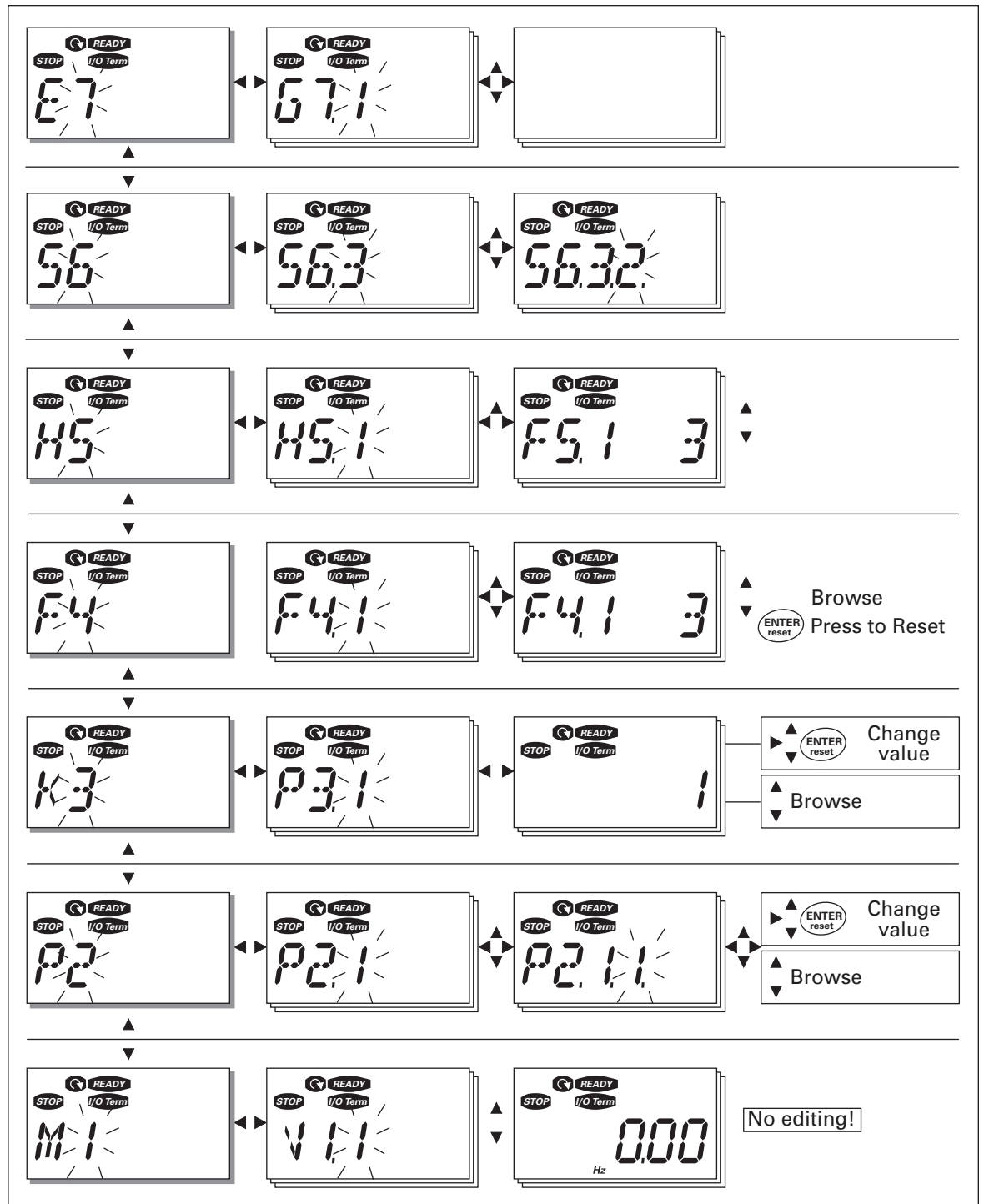

Figure 5-4: Keypad Navigation Chart

Table 5-4: Main Menu Functions

Code	Menu	Min.	Max.	Selections
M1	Monitoring menu	V1.1	V1.24	See Page 5-7 for the monitoring values
P2	Parameter menu	P2.1	P2.10	P2.1 = Basic parameters P2.2 = Input signals P2.3 = Output signals P2.4 = Drive control P2.5 = Prohibit frequencies P2.6 = Motor control P2.7 = Protections P2.8 = Autorestart P2.9 = PID control P2.10 = Pump and fan control See the Multi-control application manual for detailed parameter lists
K3	Keypad control menu	P3.1	P3.6	P3.1 = Selection of control place R3.2 = Keypad reference P3.3 = Keypad direction P3.4 = Stop button activation P3.5 = PID reference 1 P3.6 = PID reference 2
F4	Active faults menu			Shows the active faults and their types
H5	Fault history menu			Shows the fault history list
S6	System menu	S6.3	S6.10	S6.3 = Copy parameters S6.5 = Security S6.6 = Keypad settings S6.7 = Hardware settings S6.8 = System info S6.9 = AI mode S6.10 = Fieldbus parameters Parameters are described on Page 5-13
E7	Expander board menu			

October 2007

Monitoring Menu (M1)

You can enter the Monitoring menu from the Main menu by pressing Menu Button Right when the location indication **M1** is visible on the display. **Figure 5-5** shows how to browse through the monitored values.

The monitored signals carry the indication **V#.#** and listed in **Table 5-5**. The values are updated once every .3 seconds.

This menu is for signal checking. The values cannot be changed. To change values of the parameters, see **Page 5-8**.

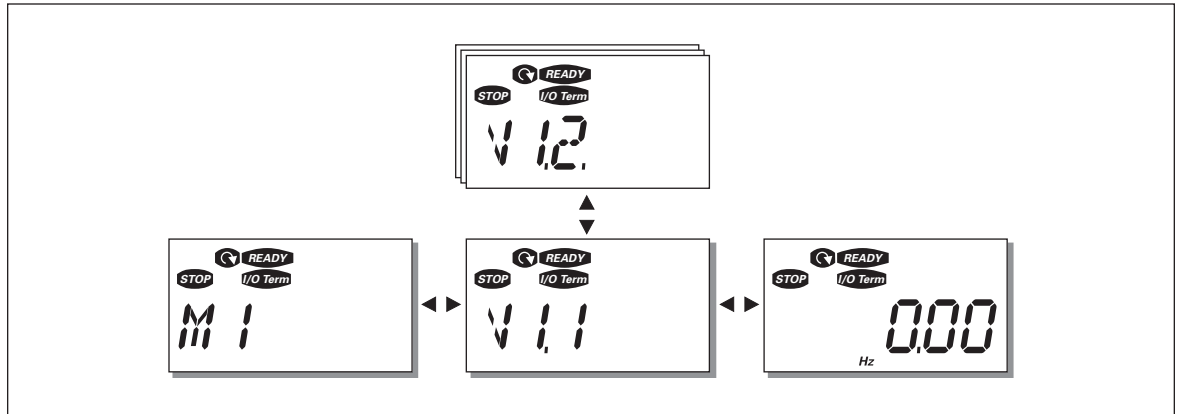

Figure 5-5: Monitoring Menu

Table 5-5: Monitored Signals

Code	Signal Name	Unit	ID	Description
V1.1	Output frequency	Hz	1	Frequency to the motor
V1.2	Frequency reference	Hz	25	
V1.3	Motor speed	rpm	2	Calculated motor speed
V1.4	Motor current	A	3	Measured motor current
V1.5	Motor torque	%	4	Calculated actual torque/nominal torque of the motor
V1.6	Motor power	%	5	Calculated actual power/nominal power of the motor
V1.7	Motor voltage	V	6	Calculated motor voltage
V1.8	DC-link voltage	V	7	Measured DC-link voltage
V1.9	Unit temperature	°C	8	Heatsink temperature
V1.10	Analog input 1		13	AI1
V1.11	Analog input 2		14	AI2
V1.12	Analog output current	mA	26	AO1
V1.13	Analog output current 1, expander board	mA	31	
V1.14	Analog output current 2, expander board	mA	32	
V1.15	DIN1, DIN2, DIN3		15	Digital input statuses
V1.16	DIE1, DIE2, DIE3		33	I/O expander board: Digital input statuses
V1.17	RO1		34	Relay output 1 status
V1.18	ROE1, ROE2, ROE3		35	I/O exp. board: Relay output statuses
V1.19	DOE1		36	I/O exp. board: Digital output 1 status
V1.20	PID Reference	%	20	In percent of the maximum process reference
V1.21	PID Actual value	%	21	In percent of the maximum actual value
V1.22	PID Error value	%	22	In percent of the maximum error value
V1.23	PID Output	%	23	In percent of the maximum output value
V1.24	Autochange outputs 1, 2, 3		30	Used only in pump and fan control

Parameter Menu (P2)

Parameter values can be edited by entering the Parameter Menu from the Main Menu when the location indication **P2** is visible on the display. The value editing procedure is presented in **Figure 5-6**.

Pressing Menu Button Right once takes you to the Parameter Group Menu (G#). Locate the desired parameter group by using the Browser buttons and press Menu Button Right again to see the group and its parameters. Use the Browser buttons to find the parameter (P#) you want to edit. Pressing Menu Button Right takes you to the edit mode. As a sign of this, the parameter value starts to blink. You can now change the value in two different ways:

- Set the desired value with the Browser buttons and confirm the change with the ENTER button. Consequently, the blinking stops and the new value is visible in the value field.
- Press Menu Button Right once more. Now you will be able to edit the value digit by digit. This may come in handy, when a relatively greater or smaller value than that on the display is desired. Confirm the change with the ENTER button.

October 2007

The value will not change unless the ENTER button is pressed. Pressing Menu Button Left takes you back to the previous menu.

Several parameters are locked, i.e. cannot be edited, when the drive is in RUN status. The drive must be stopped to edit these parameters.

The parameter values can also be locked using the function in menu **S6** (see **Page 5-16**).

You can return to the Main Menu any time by pressing Menu Button Left for 1 to 2 seconds.

The basic parameters are listed in **Chapter 6**. You will find the complete parameter lists and descriptions in the *Multi-Control Application* manual.

Once in the last parameter of a parameter group, you can move directly to the first parameter of that group by pushing the Browser button up.

Once in the last parameter of a parameter group, you can move directly to the first parameter of that group by pressing Browser Button Up.

See the diagram for parameter value change procedure in **Figure 5-6**.

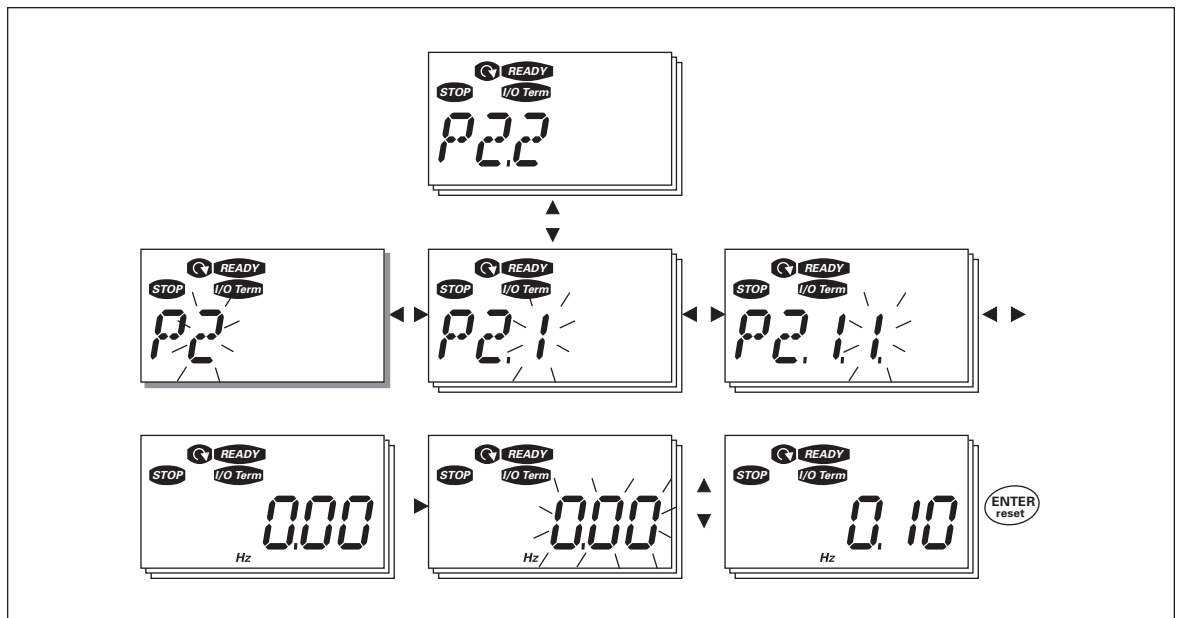

Figure 5-6: Parameter Value Change Procedure

Keypad Control Menu (K3)

In the Keypad Control Menu, you can choose the control place, edit the frequency reference and change the direction of the motor. You can enter the submenu level by pressing Menu Button Right.

Table 5-6: Keypad Control Menu Selections

Parameters in Menu K3	Selections
P3.1 = Selection of control place	1 = I/O terminals 2 = Keypad 3 = Fieldbus
R3.2 = Keypad reference	
P3.3 = Keypad direction	0 = Forward 1 = Reverse
P3.4 = Stop button activation	0 = Limited function of Stop button 1 = Stop button always enabled
P3.5 = PID reference 1	
P3.6 = PID reference 2	

Selection of Control Place

There are three different places (sources) where the drive can be controlled. For each control place, a different symbol will appear on the alphanumeric display:

- I/O terminals
- Keypad (panel)
- Fieldbus

You can change the control place by entering the edit mode with Menu Button Right. The options can then be browsed with the Browser buttons. Select the desired control place with the ENTER button. See **Figure 5-7**.

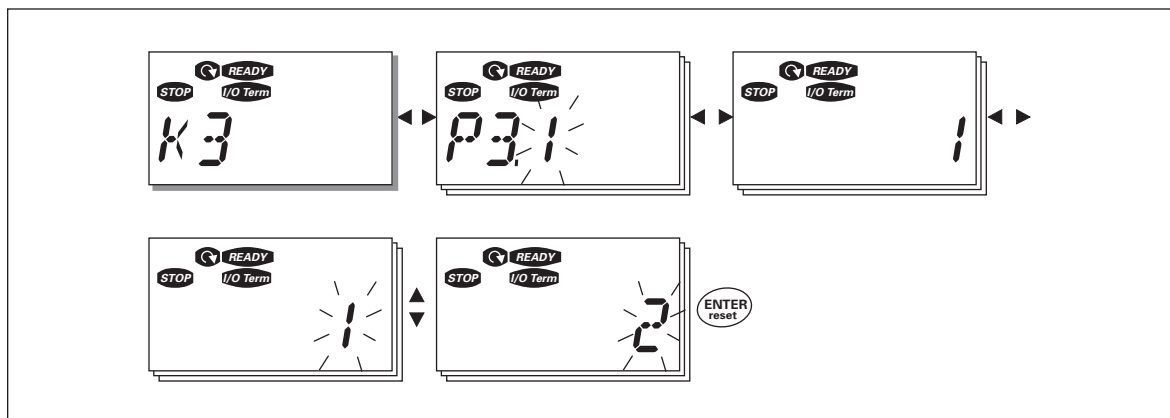

Figure 5-7: Selection of Control Place

October 2007

Keypad Reference

The keypad reference submenu (**R3.2**) displays and allows the operator to edit the frequency reference. The changes will take place immediately. **This reference value will not, however, influence the rotation speed of the motor unless the keypad has been selected as the active control place.**

Note: The maximum difference between the output frequency and the keypad reference is 6 Hz. The program automatically monitors the keypad reference value.

You may edit the reference value (pressing the ENTER button is not necessary). See **Figure 5-6**.

Keypad Direction

The keypad direction submenu displays and allows the operator to change the rotating direction of the motor. **This setting will not, however, influence the rotation direction of the motor unless the keypad has been selected as the active control place.**

Note: See **Table 5-6** for how to change the rotation direction.

STOP Button Activated

By default, pushing the STOP button will **always** stop the motor regardless of the selected control place. You can disable this function by giving parameter 3.4 the value **0**. If the value of this parameter is **0**, the STOP button will stop the motor only **when the keypad has been selected as the active control place.**

Note: See **Table 5-6** for how to change the value of this parameter.

Active Faults Menu (F4)

You can enter the Active Faults menu from the Main Menu by pressing Menu Button Right when the location indication **F4** is visible on the keypad display.

The memory of active faults can store a maximum of five faults in the order of appearance. The display can be cleared with the RESET button and the read-out will return to the same state it was in before the fault trip. The fault remains active until it is cleared with the RESET button or with a reset signal from the I/O terminal.

Note: Remove external Start signal before resetting the fault to prevent unintentional restart of the drive.

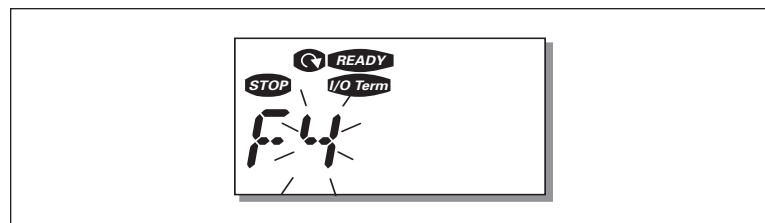

Figure 5-8: Normal State, No Faults

Fault Types

The drive has two types of faults. These types differ from each other on the basis of the subsequent behavior of the drive. See **Table 5-7**.

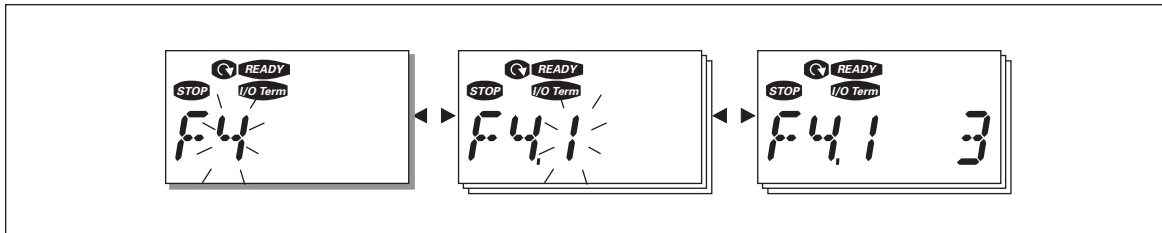

Figure 5-9: Fault Display

Table 5-7: Fault Types

Fault Type Symbol	Meaning
A (Alarm)	This type of fault is a sign of an unusual operating condition. It does not cause the drive to stop, nor does it require any special actions. The "A fault" remains in the display for about 30 seconds.
F (Fault)	An "F fault" makes the drive stop. Actions need to be taken to restart the drive.

Note: Fault Codes are listed in **Appendix A**.

Fault History Menu (H5)

You can enter the Fault History menu from the Main Menu by pressing Menu Button Right when the location indication **H5** is visible on the keypad display.

All faults are stored in the Fault History menu where you can browse them with the Browser buttons. You can return to the previous menu any time by pressing Menu Button Left.

The memory of the drive can store a maximum of 5 faults in order of appearance. The latest fault is indicated by H5.1, the one before that by H5.2 and so on. If there are 5 uncleared faults in the memory, the next fault will erase the oldest fault from the memory.

Pressing the ENTER button for about 2 to 3 seconds resets the whole fault history.

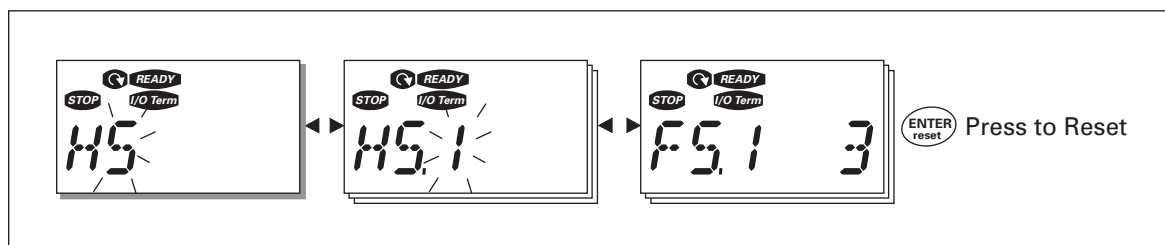

Figure 5-10: Fault History Menu

October 2007

System Menu (S6)

You can enter the System Menu from the Main menu by pressing Menu Button Right when the location indication **S6** is visible on the first line of the keypad display.

The controls associated with the general use of the drive, such as keypad settings, customized parameter sets or information about the hardware and software are located under the System Menu.

Table 5-8 has a list of the functions available in the System Menu.

Table 5-8: System Menu Functions

Code	Function	Min.	Max.	Unit	Default	Cust.	Selections
S6.3	Copy parameters						
P6.3.1	Parameter sets						0 = Select 1 = Store set 1 2 = Load set 1 3 = Store set 2 4 = Load set 2 5 = Load factory defaults 6 = Fault 7 = Wait 8 = OK
S6.5	Security						
P6.5.2	Parameter lock	0	1		0		0 = Change Enabled 1 = Change Disabled
S6.6	Keypad settings						
P6.6.1	Default page	0			1.1		
P6.6.3	Timeout time	5	65535	s	1200		
S6.7	Hardware settings						
P6.7.2	Fan control	0			0		0 = Continuous 1 = Temperature (only sizes MF4 and larger)
P6.7.3	HMI acknowledg. timeout	200	5000	mS	200		
P6.7.4	HMI number of retries	1	10		5		
S6.8	System info						
S6.8.1	Counters menu						
C6.8.1.1	Mwh counter			KWh			
C6.8.1.2	Operating days counter			hh:mm:ss			
C6.8.1.3	Operating hours counter			hh:mm:ss			
S6.8.2	Trip counters						
T6.8.2.1	MWh trip counter			kWh			
P6.8.2.2	Clear MWh trip counter						0 = No action 1 = Clear MWh trip counter
T6.8.2.3	Operating days trip counter						

Table 5-8: System Menu Functions (Continued)

Code	Function	Min.	Max.	Unit	Default	Cust.	Selections
T6.8.2.4	Operating hours trip counter			hh:mm:ss			
P6.8.2.5	Clear operating time counter						0 = No action 1 = Clear T6.8.2.3, T6.8.2.4
S6.8.3	Software info						
I6.8.3.1	Software package						Scroll information with menu button right
I6.8.3.2	System SW version						
I6.8.3.3	Firmware interface						
I6.8.3.4	System load			%			
S6.8.4	Application info						
S6.8.4.1	Application						
A6.8.4.1.1	Application ID						
A6.8.4.1.2	Application version						
A6.8.4.1.3	Firmware interface						
S6.8.5	Hardware info						
I6.8.5.2	Unit voltage			V			
I6.8.5.3	Brake chopper						0 = Not present, 1 = Present
S6.8.6	Options						
S6.8.6.1	Slot E OPT-						Note: the submenus do not show if no option board is installed
I6.8.6.1.1	Slot E status	1	5				1 = Connection lost 2 = Initializing 3 = Run 5 = Fault
I6.8.6.1.2	Slot E program version						
S6.8.6.2	Slot D OPT-						Note: the submenus do not show if no option board is installed
I6.8.6.2.1	Slot D status	1	5				1 = Connection lost 2 = Initializing 3 = Run 5 = Fault
I6.8.6.2.2	Slot D program version						
S6.9	AI mode						
P6.9.1	AIA1 mode	0	1		0		0 = Voltage input 1 = Current input (Types MF4 – MF6)
P6.9.2	AIA2 mode	0	1		1		0 = Voltage input 1 = Current input
S6.10	Fieldbus parameters						
I6.10.1	Communication status						

October 2007

Table 5-8: System Menu Functions (Continued)

Code	Function	Min.	Max.	Unit	Default	Cust.	Selections
P6.10.2	Fieldbus protocol	1	1		1		0 = Not used 1 = Modbus protocol
P6.10.3	Slave address	1	255		1		Addresses 1 – 255
P6.10.4	Baud rate	0	8		5		0 = 300 baud 1 = 600 baud 2 = 1200 baud 3 = 2400 baud 4 = 4800 baud 5 = 9600 baud 6 = 19200 baud 7 = 38400 baud 8 = 57600 baud
P6.10.5	Stop bits	0	1		0		0 = 1 1 = 2
P6.10.6	Parity type	0	2		0		0 = None 1 = Odd 2 = Even
P6.10.7	Communication timeout	0	300	s	0		0 = Not used 1 = 1 second 2 = 2 seconds, etc.

Copy Parameters

The Copy parameters submenu (**S6.3**) is located under the System menu.

The SLX9000 drive allows the user to store and load two customized parameter sets (all parameters included in the application, not the system menu parameters) and to load back the factory default parameter values.

Parameter Sets (S6.3.1)

On Parameter sets page (**S6.3.1**), push the Menu Button Right to enter the Edit menu. You can store or load two customized parameter sets or load back the factory defaults. Confirm with the ENTER button. Wait until **8 (=OK)** appears on the display.

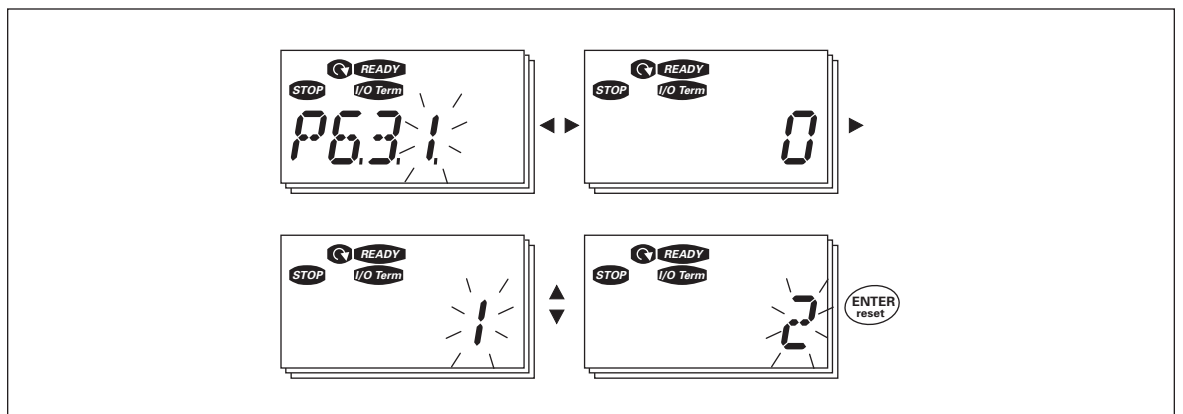

Figure 5-11: Storing and Loading of Parameter Sets

Security

The Security submenu (**S6.5**) under the system menu has a function that allows the user to prohibit changes to the parameters.

Parameter Lock (P6.5.2)

If the parameter lock is activated the parameter values cannot be edited.

Note: This function does not prevent unauthorized editing of parameter values.

Enter the edit mode by pushing the Menu Button Right. Use the Browser buttons to change the parameter lock status (0 = changes enabled, 1 = changes disabled). Accept the change with the ENTER button or return to the previous level with the Menu Button Left.

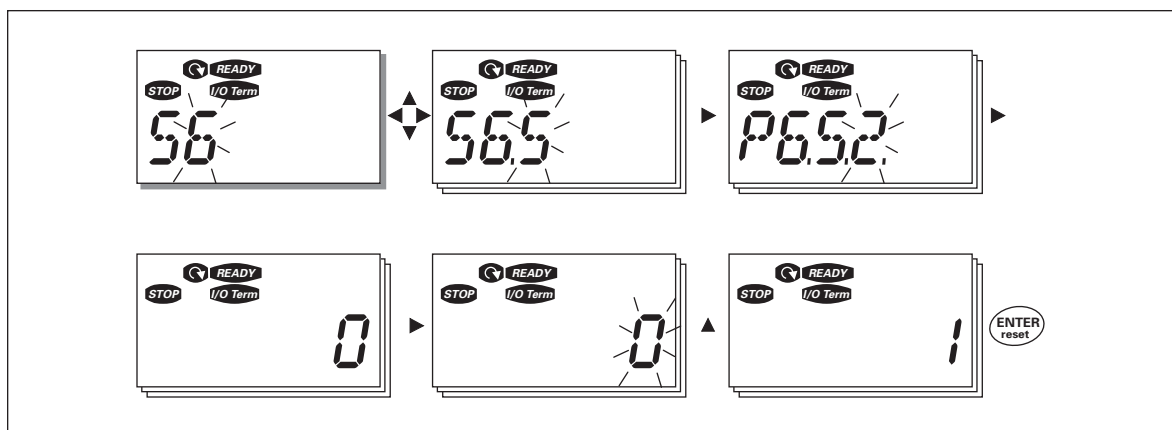

Figure 5-12: Parameter Locking

Keypad Settings

In the Keypad Settings submenu under the System menu, you can further customize your drive operator interface.

Locate the Keypad Setting submenu (**S6.6**). Under the submenu, there are two pages (**P#**) associated with the keypad operation:

Default Page (P6.6.1)

Here you can set the location (page) to which the display automatically moves as the Timeout Time (see below) has expired or as the power is switched on to the keypad.

Press the Menu Button Right once to enter the edit mode. Pressing the Menu Button Right once again makes you able to edit the number of the submenu/page digit by digit. Confirm the new default page value with the ENTER button. You can return to the previous step anytime by pushing the Menu Button Left.

Note: If you set a page that does not exist in the menu, the display will automatically move to the last available page in the menu.

October 2007

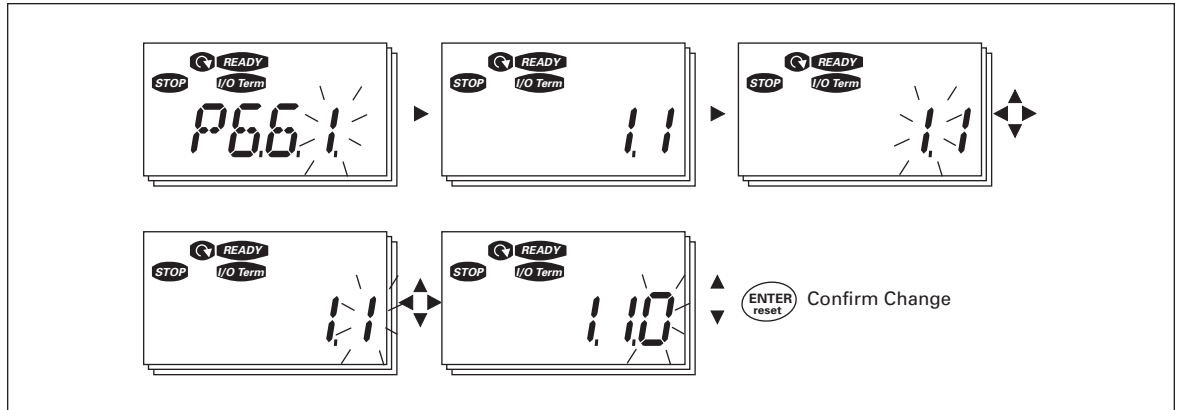

Figure 5-13: Default Page Function

Timeout Time (P6.6.3)

The Timeout Time setting defines the time after which the keypad display returns to the Default page (P6.6.1).

Enter the edit mode by pressing Menu Button Right. Set the desired timeout time and confirm it with the ENTER button. You can return to the previous menu at any time by pressing Menu Button Left.

Note: This function cannot be disabled.

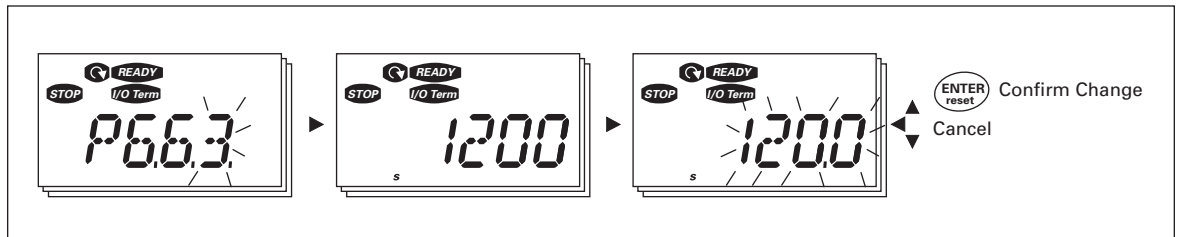

Figure 5-14: Timeout Time Setting

Hardware Settings

In the Hardware settings submenu (S6.7) you can further customize the settings of the drive with three parameters: Fan control, HMI acknowledgement timeout and HMI retry.

Fan Control (P6.7.2)

Note: Only the higher power modules of MF3 have been equipped with a cooling fan, in lower power modules of MF3 the cooling fan is available as optional equipment.

If the cooling fan has been installed in MF3 it runs continuously when the power is switched on.

This function allows you to control the drive's cooling fan. You can set the fan to run continuously when the power is switched on or depending on the temperature of the unit. If the latter function has been selected the fan is switched on automatically when the heatsink temperature reaches 60°C. The fan receives a stop command when the heatsink temperature falls to 55°C. However the fan runs for about a minute after receiving the stop command, as well as after changing the value from **0** (*Continuous*) to **1** (*Temperature*).

Enter the edit mode by pushing the Menu Button Right. The present mode shown starts to blink. Use the Browser buttons to change the fan mode. Accept the change with the ENTER button or return to the previous level with the Menu Button Left.

HMI Acknowledge Timeout (P6.7.3)

This function allows the user to change the timeout of the HMI acknowledgement time.

Note: If the drive has been connected to the PC with a **normal cable**, the default values of parameters 6.7.3 and 6.7.4 (200 and 5) **must not be changed**.

If the drive has been connected to the PC via a modem and there is delay in transferring messages, the value of par. 6.7.3 must be set according to the delay as follows:

Example:

- Transfer delay between the drive and the PC = 600 ms
- The value of par. 6.7.3 is set to 1200 mS (2 x 600, sending delay + receiving delay)
- The corresponding setting shall be entered in the (Misc)-part of the file NCDrive.ini:
 - Retries = 5
 - AckTimeOut = 1200
 - TimeOut = 6000

It must also be considered that intervals that are shorter than the AckTimeOut-time cannot be used in NC-Drive monitoring.

Enter the edit mode by pushing the Menu Button Right. Use the Browser buttons to change the acknowledgement time. Accept the change with the ENTER button or return to the previous level with the Menu Button Left. See **Figure 5-15** for how to change the HMI acknowledgement timeout.

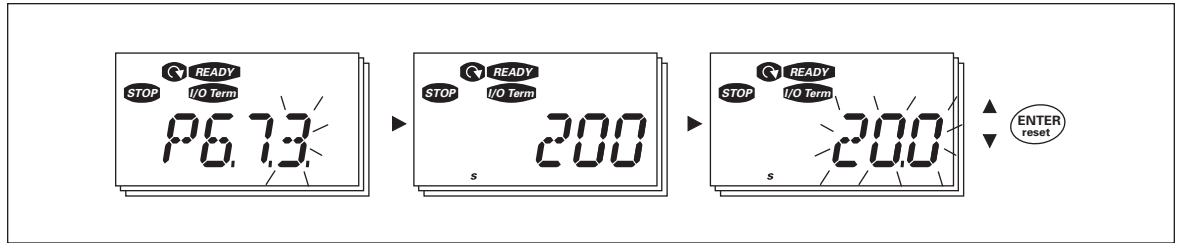

Figure 5-15: HMI Acknowledge Timeout

Number of Retries to Receive HMI Acknowledgement (P6.7.4)

With this parameter you can set the number of times the drive will try receive acknowledgement if this does not succeed within the acknowledgement time (P6.7.3)

Enter the edit mode by pushing the Menu Button Right. The present value shown starts to blink. Use the Browser buttons to change the amount of retries. Accept the change with the ENTER button or return to the previous level with the Menu Button Left.

System Information

In the submenu S6.8 under the System menu you can find drive-related hardware and software information as well as operation-related information.

Enter the Info menu by pressing the Menu Button Right. Now you can browse through the information pages with the Browser buttons.

Counters Submenu (S6.8.1)

In the Counters submenu (**S6.8.1**) you can find information related to the drive operation times, i.e. the total numbers of MWh, operation days and operation hours passed so far. Unlike the counters in the trip counters menu, these counters cannot be reset.

Note: The operation time counter (days and hours) always runs when the power is on.

Table 5-9: Counter Pages

Page	Counter
C6.8.1.1	MWh counter
C6.8.1.2	Operation day counter
C6.8.1.3	Operation hour counter

Trip Counters Submenu (S6.8.2)

Trip counters (menu **S6.8.2**) are counters with values of which can be reset i.e. restored to zero. You have the following resettable counters at your disposal:

Table 5-10: Trip Counter Pages

Page	Counter
C6.8.2.1	MWh counter
P6.8.2.2	Clear mWh counter
T6.8.2.3	Operation day counter
T6.8.2.4	Operation hour counter
P6.8.2.5	Clear operation time counter

Note: The trip counters only run when the motor is running.

Example: When you want to reset the operation counters, you should do the following:

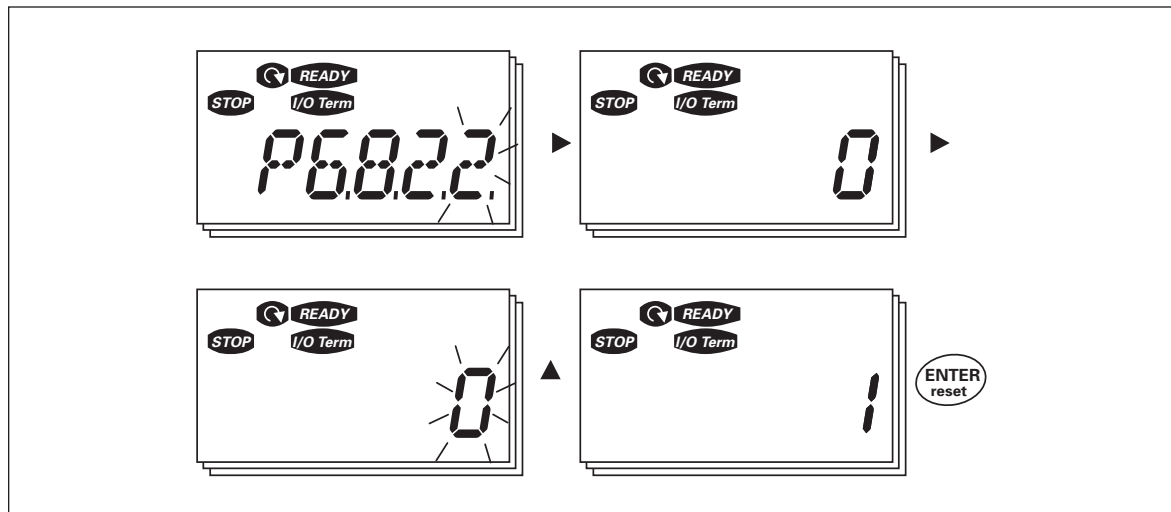
**Figure 5-16: MWh Counter Reset***Software Info Submenu (S6.8.3)*

The following information can be found under the Software Info submenu (S6.8.3):

Table 5-11: Software Information Pages

Page	Content
I6.8.3.1	Software package
I6.8.3.2	System software version
I6.8.3.3	Firmware interface
I6.8.3.4	System load

October 2007

Application Information Submenu (S6.8.4)

You can find the following information from the Application Info submenu (S6.8.4):

Table 5-12: Application Information Pages

Page	Content
A6.8.4.1	Application
D6.8.4.1.1	Application ID
D6.8.4.1.2	Version
D6.8.4.1.3	Firmware interface

Hardware Information Submenu (S.8.5)

You can find the following information from the Hardware Info submenu (S6.8.5):

Table 5-13: Hardware Information Pages

Page	Content
I6.8.5.2	Unit voltage
I6.8.5.3	Brake chopper

Connected Options Submenu (S6.8.6)

The Connected options submenu (S6.8.6) shows the following information on the option board connected to the drive:

Table 5-14: Connected Options Submenu

Page	Content
S6.8.6.1	Slot E option board
I6.8.6.1.1	Slot E option board status
I6.8.6.1.2	Slot E program version
S6.8.6.2	Slot D option board
I6.8.6.2.1	Slot D option board status
I6.8.6.2.2	Slot D program version

In this submenu you find information about the option board connected to the control board (see **Chapter 4**).

You can check the status of the slot by entering the board submenu with the Menu Button Right and using the Browser buttons. Push the Menu Button Right again to display the status of the board. The selections are shown in **Table 5-8**. The keypad will also display the program version of the respective board when you push either one of the Browser buttons.

For more information on the expander board-related parameters, see **Page 5-26**.

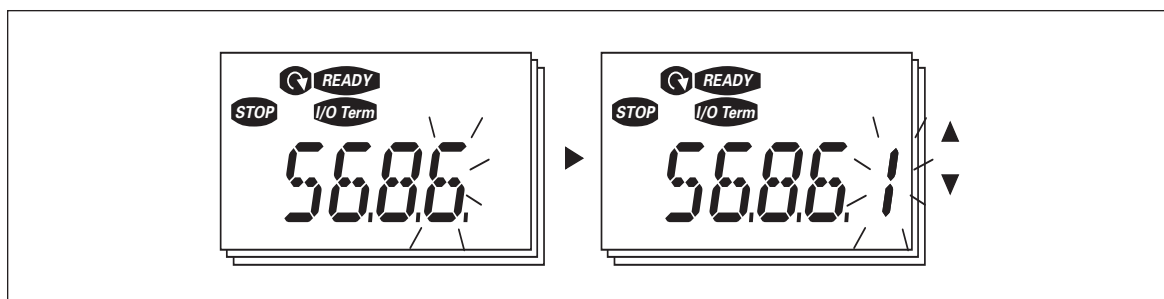

Figure 5-17: Expander Board Information Menu

AI mode

The parameters P6.9.1 and P6.9.2 select the analog input mode. **P6.9.1** appears only in classes MF4 – MF6.

- 0 = voltage input (par. 6.9.1 default)
- 1 = current input (par. 6.9.2 default)

Note: Make sure that the jumper selections correspond to the selections of this parameter. See **Figure 4-4**.

Modbus Interface

SLX9000 has a built-in Modbus RTU bus interface. The signal level of the interface is in accordance with the RS-485 standard.

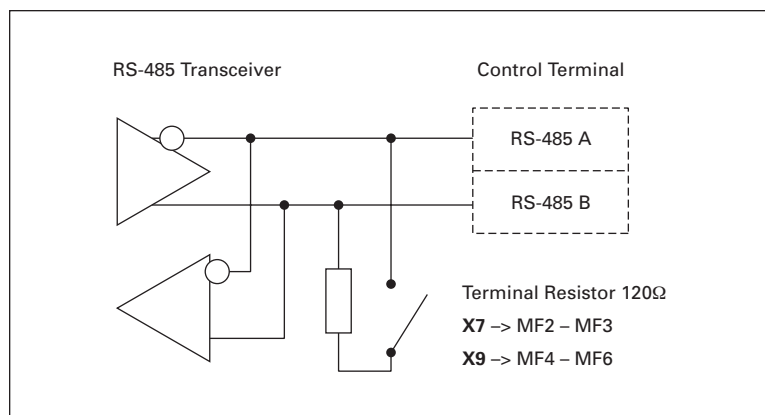

Figure 5-18: Modbus Interface

Protocol:	Modbus RTU
Baud rates:	300, 600, 1200, 2400, 4800, 9600, 19200, 38700, 57600 (bit/s)
Signal level:	RS-485 (TIA/EIA-485-A)
Input impedance:	2 k Ω

October 2007

Modbus RTU Protocol

Modbus RTU protocol is a simple but effective fieldbus protocol. Modbus network has a bus topology, where every device has an individual address. With the help of the individual bus addresses the commands are directed to the single devices within the network. Modbus supports also broadcast-type messages, that are received by every device of the bus. Broadcast messages are sent to the address "0" which is reserved for these messages.

The protocol includes CRC error detection and parity check for preventing the handling of messages containing errors. In Modbus the data is transferred in hex mode a synchronically and a break of approximately 3.5 characters is used as an end character. The length of the break depends on the used baud rate.

Table 5-15: Modbus Commands Supported by SLX9000

Function Code	Function Name	Address	Broadcast Messages
03	Read Holding Register	All ID numbers	No
04	Read Input Register	All ID numbers	No
06	Preset Single Register	All ID numbers	Yes
16	Preset Multiple Register	All ID numbers	Yes

Termination Resistor

The RS-485 bus is terminated with 120Ω termination resistors in both ends. SLX9000 has a built-in termination resistor which is switched off as a default. See the jumper selections in **Chapter 4**.

Modbus Address Area

The Modbus bus of SLX9000 uses the ID numbers of the application as addresses. The ID numbers can be found in the parameter tables of the application manual.

When several parameters/monitoring values are read at a time they must be consecutive. 11 addresses can be read and the addresses can be parameters or monitoring values.

Modbus Process Data

Process data is an address area for fieldbus control. Fieldbus control is active when the value of parameter 3.1 (Control place) is 2 (= fieldbus). The contents of the process data has been determined in the application. The following tables present the process data contents in the Multi-Control Application.

Table 5-16: Output Process Data

Addr.	Modbus Register	Name	Scale	Type
2101	32101, 42101	FB Status Word	—	Binary coded
2102	32102, 42102	FB General Status Word	—	Binary coded
2103	32103, 42103	FB Actual Speed	0.01	%
2104	32104, 42104	Motor speed	0.01	+/- Hz
2105	32105, 42105	Motor speed	1	+/- Rpm
2106	32106, 42106	Motor current	0.1	A
2107	32107, 42107	Motor Torque	0.1	+/- % (of nominal)
2108	32108, 42108	Motor Power	0.1	+/- % (of nominal)
2109	32109, 42109	Motor Voltage	0.1	V
2110	32110, 42110	DC Voltage	1	V
2111	32111, 42111	Active Fault	—	Fault code

Table 5-17: Input Process Data

Addr.	Modbus Register	Name	Scale	Type
2001	32001, 42001	FB Control Word	—	Binary coded
2002	32002, 42002	FB General Control Word	—	Binary coded
2003	32003, 42003	FB Speed Reference	0.01	%
2004	32004, 42004	PID Control Reference	0.01	%
2005	32005, 42005	PID Actual Value	0.01	%
2006	32006, 42006	—	—	—
2007	32007, 42007	—	—	—
2008	32008, 42008	—	—	—
2009	32009, 42009	—	—	—
2010	32010, 42010	—	—	—
2011	32011, 42011	—	—	—

Table 5-18: Status Word

15	14	13	12	11	10	9	8	7	6	5	4	3	2	1	0
—	—	—	—	—	—	—	—	F	Z	AREF	W	FLT	DIR	RUN	RDY

Information about the status of the device and messages is indicated in the Status word. The Status word is composed of 16 bits the meanings of which are described in **Table 5-19**.

Table 5-19: Actual Speed

15	14	13	12	11	10	9	8	7	6	5	4	3	2	1	0
MSB	—	—	—	—	—	—	—	—	—	—	—	—	—	—	LSB

This is actual speed of the drive. The scaling is -10000 – 10000. In the application, the value is scaled in percentage of the frequency area between set minimum and maximum frequency.

Table 5-20: Control Word

15	14	13	12	11	10	9	8	7	6	5	4	3	2	1	0
—	—	—	—	—	—	—	—	—	—	—	—	—	RST	DIR	RUN

In SLX9000 applications, the three first bits of the control word are used to control the drive. However, you can customize the content of the control word for your own applications because the control word is sent to the drive as such.

Table 5-21: Speed Reference

15	14	13	12	11	10	9	8	7	6	5	4	3	2	1	0
MSB	—	—	—	—	—	—	—	—	—	—	—	—	—	—	LSB

This is the Reference 1 to the drive. Used normally as Speed reference. The allowed scaling is -10000 – 10000. In the application, the value is scaled in percentage of the frequency area between the set minimum and maximum frequencies.

Table 5-22: Bit Definitions

Bit	Description	
	Value = 0	Value = 1
RUN	Stop	Run
DIR	Clockwise	Counterclockwise
RST	Rising edge of this bit will reset active fault	
RDY	Drive not ready	Drive ready
FLT	No fault	Fault active
W	No warning	Warning active
AREF	Ramping	Speed reference reached
Z	—	Drive is running at zero speed
F	—	Flux Ready

Fieldbus Parameters

RS-485 Communication Status (I6.10.1)

With this function you can check the status of the RS-485 bus. If the bus is not in use, this value is 0.

xx.yyy

xx = 0 – 64 (Number of messages containing errors)

yyy = 0 – 999 (Number of messages received correctly)

Fieldbus Protocol (P6.10.2)

With this function you can select the fieldbus communications protocol.

0 = Not used

1 = Modbus protocol

Slave Address (P6.10.3)

Sets the slave address for the Modbus protocol. You can set any address between 1 and 255.

Baud Rate (P6.10.4)

Selects the baud rate used with the Modbus communication.

- 0 = 300 baud
- 1 = 600 baud
- 2 = 1200 baud
- 3 = 2400 baud
- 4 = 4800 baud
- 5 = 9600 baud
- 6 = 19200 baud
- 7 = 38400 baud
- 8 = 57600 baud

Stop Bits (P6.10.5)

Sets number of stop bits used in Modbus communication.

- 0 = 1 stop bit
- 1 = 2 stop bits

Parity Type (P6.10.6)

Here you can select the type of parity checking used with the Modbus communication.

- 0 = None
- 1 = Odd
- 2 = Even

Communication time-out (P6.10.7)

If communication between two messages is broken for a longer time than that defined by this parameter, a communication error is initiated. If the value of this parameter is 0, the function is not used.

- 0 = Not used
- 1 = 1 second
- 2 = 2 seconds, etc.

Expander Board Menu (E7)

The *Expander board menu* makes it possible for the user 1) to see which expander board is connected to the control board and 2) to reach and edit the parameters associated with the expander board.

Enter the following menu level (**E#**) with the Menu Button Right. You can view and edit the parameter values in the same way as described on **Page 5-8**.

Further Keypad Functions

The SLX9000 control keypad embodies additional application-related functions. See Eaton's *Multi-Control Application Manual* for more information.

October 2007

Chapter 6 — Start-Up

Safety Precautions

Before start-up, note the following directions and warnings:

 **WARNING**

- 1** Internal components and circuit boards of the drive (except for the galvanically isolated I/O terminals) are **live** when the drive is connected to mains potential. **Coming into contact with this voltage is extremely dangerous and may cause death or severe injury.**
- 2** The motor terminals U, V, W and the DC-link/brake resistor terminals +/- are **live** when the drive is connected to DC supply, **even if the motor is not running.**
- 3** The control I/O-terminals are isolated from the mains potential. However, the relay outputs and other I/O-terminals may have a dangerous control voltage present even when the drive is disconnected from power supply.
- 4** Do not make any connections when the drive is connected to the power supply.
- 5** After having disconnected the drive, wait until the fan stops and the indicators on the keypad go out (if no keypad is attached see the indicator through the keypad base). Wait 5 more minutes before doing any work on drive connections. Do not open the cover before the time has expired.
- 6** Before connecting the drive to power supply, make sure that the drive's front cover is closed.

Sequence of Operation

1. Carefully read the safety instructions in the front of this manual and above and follow them.
2. After the installation, make sure that:
 - both the drive and the motor are grounded.
 - the power supply and motor cables comply with the requirements given in **Chapter 3**.
 - the control cables are located as far as possible from the power cables (see **Chapter 3**) and the shields of the shielded cables are connected to protective ground. The wires may not touch the electrical components of the drive.
 - **For option boards only:** make sure that the common ends of digital input groups are connected to +24V or ground of the I/O terminal or the external supply.
3. Check the quality and quantity of cooling air. (See **Chapter 2**, Mounting Space Dimensions.)
4. Check the inside of the drive for condensation.
5. Check that all Start/Stop switches connected to the I/O terminals are in Stop position.
6. Connect the drive to power supply.
7. Set the parameters of group 1 according to the requirements of your application (see application manual). At least the following parameters should be set:
 - motor nominal voltage
 - motor nominal frequency
 - motor nominal speed
 - motor nominal current

You will find the values needed for the parameters on the motor nameplate.

Note: You can also run the Start-Up Wizard. See **Page 6-4**.

8. Perform run test without motor.
Perform either Test A or Test B:
Test A — Controls from the I/O terminals:
 - Turn the Start/Stop switch to ON position.
 - Change the frequency reference (potentiometer).
 - Check in the Monitoring Menu M1 that the value of Output Frequency changes according to the change of frequency reference.
 - Turn the Start/Stop switch to OFF position.

October 2007

- Test B**— Control from the control keypad:
- Change the control from the I/O terminals to the keypad as advised on **Page 5-10**.
 - Press the START button on the keypad.
 - Move over to the Keypad Control Menu K3 and Keypad Reference submenu (see Keypad Reference on **Page 5-11**) and change the frequency reference with the Browser up and down buttons.
 - Check in Monitoring Menu M1 that the value of Output Frequency changes according to the change of frequency reference.
 - Press the STOP button on the keypad.
9. Run the start-up tests without the motor being connected to the process. If this is not possible, make sure that running each test is safe prior to running it. Inform your co-workers of the tests.
- Switch off the supply voltage and wait until the drive has stopped as advised on **Page 6-1, Safety Precautions**.
 - Connect the motor cable to the motor and to the motor cable terminals of the drive.
 - Make sure that all Start/Stop switches are in Stop positions.
 - Switch the supply voltage ON.
 - Repeat test 8A or 8B.
10. Connect the motor to the process (if the start-up test was run without the motor being connected).
- Before running the tests, make sure that this can be done safely.
 - Inform your co-workers of the tests.
 - Repeat test 8A or 8B.

Start-Up Wizard

SLX9000 has a built-in start-up wizard, that speeds up the programming of the drive. The wizard helps you choose between four different operating modes, Standard, Fan, Pump and High Performance. Each mode has automatic parameter settings optimized for the mode in question. The programming wizard is started by pressing the STOP button for 5 seconds, when the drive is in stop mode. See **Figure 6-1** for the procedure:

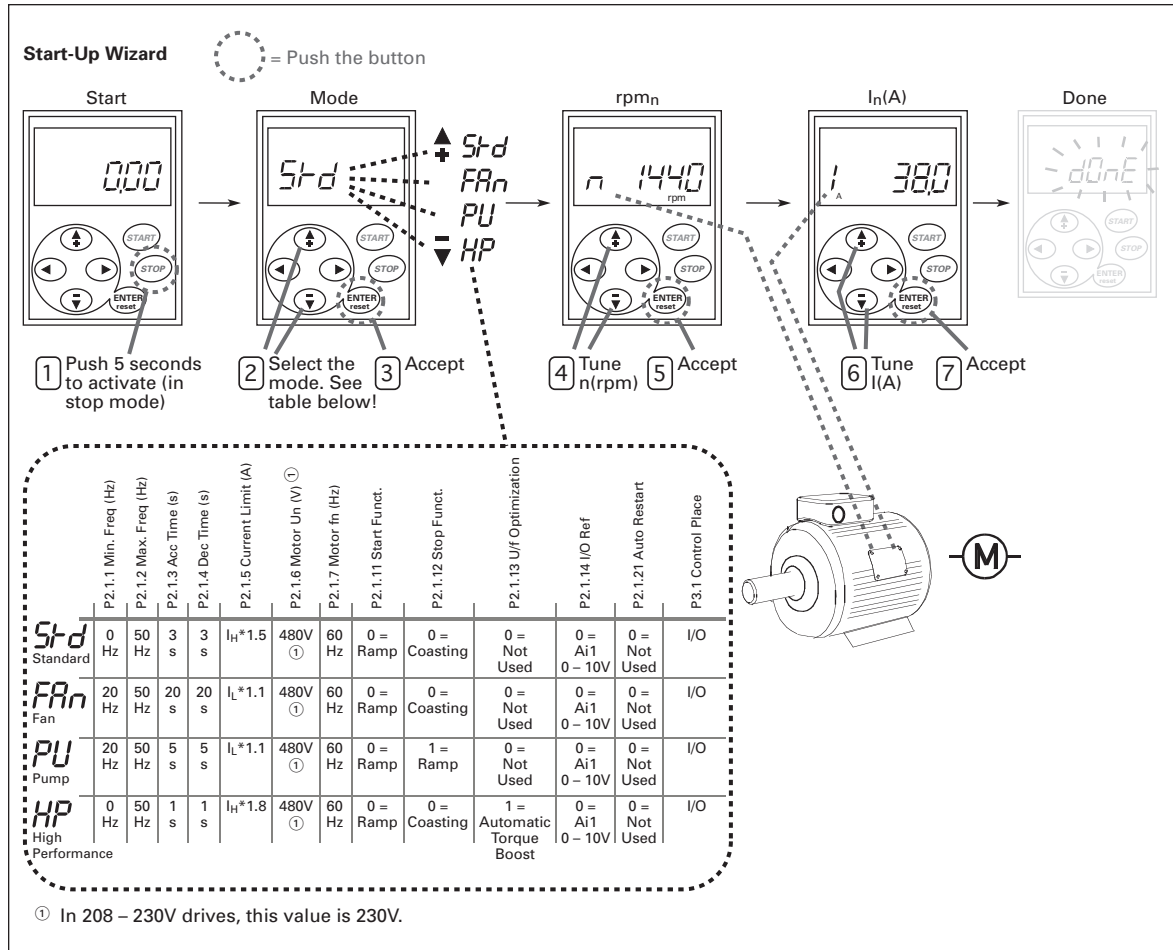

Figure 6-1: SLX9000 Start-Up Wizard



IMPORTANT

Start-Up Wizard returns all other parameters to factory defaults!

Note: See the application manual for detailed parameter descriptions.

October 2007

Chapter 7 — Basic Application

On the next pages you will find the list of parameters that are essential for the commissioning of the drive. You will find more details of these and other special parameters in **Chapter 9**.

Note: If you wish to edit the special parameters, you must set the value of par. 2.1.22 to 0.

Column explanations:

Code	=	Location indication on the keypad; Shows the operator the present param. number
Parameter	=	Name of parameter
Min	=	Minimum value of parameter
Max	=	Maximum value of parameter
Unit	=	Unit of parameter value; Given if available
Default	=	Value preset by factory
Cust	=	Customer's own setting
ID	=	ID number of the parameter (used with PC tools)
Ⓢ	=	On the parameter code: parameter value can only be changed after the drive has been stopped.

Monitoring Values (Control Keypad: Menu M1)

The monitoring values are the actual values of parameters and signals as well as statuses and measurements. Monitoring values cannot be edited. See **Page 5-7** for more information.

Table 7-1: Monitoring Values

Code	Parameter	Unit	ID	Description
V1.1	Output frequency	Hz	1	Frequency to the motor
V1.2	Frequency reference	Hz	25	
V1.3	Motor speed	rpm	2	Calculated motor speed
V1.4	Motor current	A	3	Measured motor current
V1.5	Motor torque	%	4	Calculated actual torque/nominal torque of the unit
V1.6	Motor power	%	5	Calculated actual power/nominal power of the unit
V1.7	Motor voltage	V	6	Calculated motor voltage
V1.8	DC-link voltage	V	7	Measured DC-link voltage
V1.9	Unit temperature	°C	8	Heatsink temperature
V1.10	Analog input 1	V	13	AI1
V1.11	Analog input 2		14	AI2
V1.12	Analog output current		26	AO1
V1.13	Analog output current 1, expander board	mA	31	
V1.14	Analog output current 2, expander board	mA	32	
V1.15	DIN1, DIN2, DIN3		15	Digital input statuses
V1.16	DIE1, DIE2, DIE3		33	I/O expander board: Digital input statuses
V1.17	RO1		34	Relay output 1 status
V1.18	ROE1, ROE2, ROE3		35	I/O exp. board: Relay output statuses
V1.19	DOE1		36	I/O exp. board: Digital output 1 status
V1.20	PID Reference	%	20	In percent of the maximum frequency
V1.21	PID Actual value	%	21	In percent of the maximum actual value
V1.22	PID Error value	%	22	In percent of the maximum error value
V1.23	PID Output	%	23	In percent of the maximum output value
V1.24	Autochange outputs 1, 2, 3		30	Used only in pump and fan control
V1.25	Mode		66	Shows the current drive configuration mode selected with start-up wizard: 0 = No mode selected (Default) 1 = Standard 2 = Fan 3 = Pump 4 = High performance

October 2007

Parameter List

Table 7-2: Basic Parameters (Control Keypad: Menu P2 → B2.1)

Code	Parameter	Min.	Max.	Unit	Default	Cust.	ID	Note
P2.1.1	Min. frequency	0.00	Par. 2.1.2	Hz	0.00		101	
P2.1.2	Max. frequency	Par. 2.1.1	320.00	Hz	50.00		102	NOTE: If f_{max} > than the motor synchronous speed, check suitability for motor and drive system
P2.1.3	Acceleration time 1	0.1	3000.0	s	1.0		103	
P2.1.4	Deceleration time 1	0.1	3000.0	s	1.0		104	
P2.1.5	Current limit	$0.1 \times I_L$	$1.5 \times I_L$	A	I_L		107	NOTE: Formulas apply approximately for drives up to MF3. For greater sizes, consult the factory.
P2.1.6 ①	Nominal voltage of the motor	180	690	V	240V:230V 480V:400V		110	
P2.1.7 ①	Nominal frequency of the motor	30.00	320.00	Hz	50.00		111	Check the rating plate of the motor
P2.1.8 ①	Nominal speed of the motor	300	20 000	rpm	1440		112	The default applies for a 4-pole motor and a nominal size drive.
P2.1.9 ①	Nominal current of the motor	$0.3 \times I_L$	$1.5 \times I_L$	A	I_L		113	Check the rating plate of the motor
P2.1.10 ①	Motor $\cos\phi$	0.30	1.00		0.85		120	Check the rating plate of the motor
P2.1.11 ①	Start function	0	1		0		505	0 = Ramp 1 = Flying start
P2.1.12	Stop function	0	1		0		506	0 = Coasting 1 = Ramp
P2.1.13	V/f optimization	0	1		0		109	0 = Not used 1 = Automatic torque boost
P2.1.14	I/O reference	0	4		0		117	0 = AI1 1 = AI2 2 = Keypad reference 3 = Fieldbus reference (FBSpeedReference) 4 = Motor potentiometer
P2.1.15	AI2 signal range	1	2		2		390	Not used if AI2 Custom min >0% or AI2 custom max. <100% 1 = 0 – 20 mA 2 = 4 – 20 mA 3 = 0 – 10V 4 = 2 – 10V

Table 7-2: Basic Parameters (Control Keypad: Menu P2 → B2.1) (Continued)

Code	Parameter	Min.	Max.	Unit	Default	Cust.	ID	Note
P2.1.16	Analog output function	0	12		1		307	<ul style="list-style-type: none"> 0 = Not used 1 = Output freq. ($0 - f_{max}$) 2 = Freq. reference ($0 - f_{max}$) 3 = Motor speed ($0 - \text{Motor nominal speed}$) 4 = Output current ($0 - I_{nMotor}$) 5 = Motor torque ($0 - T_{nMotor}$) 6 = Motor power ($0 - P_{nMotor}$) 7 = Motor voltage ($0 - U_{nMotor}$) 8 = DC-link volt ($0 - U_{nMotor}$) 9 = PI controller ref. value 10 = PI contr. act. value 1 11 = PI contr. error value 12 = PI controller output
P2.1.17 ①	DIN2 function	0	10		1		319	<ul style="list-style-type: none"> 0 = Not used 1 = Start Reverse 2 = Reverse 3 = Stop pulse 4 = External fault, cc 5 = External fault, oc 6 = Run enable 7 = Preset speed 2 8 = Motor pot. UP (cc) 9 = Disable PID (Direct freq. reference) 10 = Interlock 1
P2.1.18 ①	DIN3 function	0	16		6		301	<ul style="list-style-type: none"> 0 = Not used 1 = Reverse 2 = External fault, cc 3 = External fault, oc 4 = Fault reset 5 = Run enable 6 = Preset speed 1 7 = Preset speed 2 8 = DC-braking command 9 = Motor pot. UP (cc) 10 = Motor pot. DOWN (cc) 11 = Disable PID (PID control selection) 12 = PID Keypad ref. 2 selection 13 = Interlock 2 14 = Thermistor input (See Page 4-9) 15 = Force CP to I/O 16 = Force CP to Fieldbus
P2.1.19	Preset speed 1	0.00	Par. 2.1.2	Hz	10.00		105	
P2.1.20	Preset speed 2	0.00	Par. 2.1.2	Hz	50.00		106	
P2.1.21	Automatic restart	0	1		0		731	<ul style="list-style-type: none"> 0 = Not used 1 = Used
P2.1.22	Parameter conceal	0	1		1		115	<ul style="list-style-type: none"> 0 = All parameters and menus visible 1 = Only group P2.1 and menus M1 – H5 visible

October 2007

Chapter 8 — Multi-Control Application

Introduction

The Multi-Control Application of the Cutler-Hammer® SLX9000 drive by Eaton's electrical business uses direct frequency reference from the analog input 1 as a default. However, a PID controller can be used (for example, in pump and fan applications), which offers versatile internal measuring and adjusting functions.

The direct frequency reference can be used for the control without the PID controller and it can be selected from the analog inputs, fieldbus, keypad, preset speeds or motor potentiometer.

Special parameters for Pump and Fan Control (Group P2.10) can be browsed and edited after changing the value of par 2.9.1 to 2 (Pump and fan control activated).

The PID controller reference can be selected from the analog inputs, fieldbus, PID keypad reference 1 or by enabling the PID keypad reference 2 via digital input. The PID controller actual value can be selected from the analog inputs, fieldbus or the actual values of the motor. PID controller can also be used when the drive is controlled via fieldbus or the control keypad.

- Digital inputs DIN2, DIN3, (DIN4) and optional digital inputs DIE1, DIE2, DIE3 are freely programmable.
- Internal and optional digital/relay and analog outputs are freely programmable.
- Analog input 1 can be programmed as current input, voltage input or digital input DIN4.

Note: If the analog input 1 has been programmed as DIN4 with parameter 2.2.6 (AI1 Signal Range), check that the jumper selections (**Figure 9-1**) are correct.

Additional functions:

- The PID controller can be used from control places I/O, keypad and fieldbus
- Identification
- Programming wizard
- Sleep function
- Actual value supervision function: fully programmable; off, warning, fault
- Programmable Start/Stop and Reverse signal logic
- Reference scaling
- 2 Preset speeds
- Analog input range selection, signal scaling, inversion and filtering
- Frequency limit supervision
- Programmable start and stop functions
- DC-brake at start and stop
- Prohibit frequency area

- Programmable VHz curve and VHz optimization
- Adjustable switching frequency
- Autorestart function after fault
- Protections and supervisions (all fully programmable; off, warning, fault):
 - Current input fault
 - External fault
 - Output phase
 - Undervoltage
 - Ground fault
 - Motor thermal, stall and underload protection
 - Thermistor
 - Fieldbus communication
 - Option board

October 2007

Control Input/Output

Table 8-1: Multi-Control Application Default Input/Output Configuration, MF4 – MF6 460V



Reference potentiometer	Terminal	Signal	Description
	1	+10V _{ref}	Reference output Voltage for potentiometer, etc.
	2	AI1+	Analog input, voltage range 0 – 10V DC Voltage input frequency reference Can be programmed as DIN4
	3	AI1-	I/O Ground Ground for reference and controls
	4	AI2+	Analog input, voltage range 0 – 10V DC, or current range 0/4 – 20 mA Current input frequency reference
	5	AI2- /GND	
	6	+24V	Control voltage output Voltage for switches, etc. max 0.1A
	7	GND	I/O ground Ground for reference and controls
	8	DIN1	Start forward Contact closed = start forward
	9	DIN2	Start reverse (programmable) Contact closed = start reverse
	10	DIN3	Multi-step speed selection 1 (programmable) Contact closed = multi-step speed
	11	GND	I/O ground Ground for reference and controls
	18	AO1+	Output frequency Analog output Programmable Range 0 – 20 mA, R _L max. 500Ω
19	AO1-		
	A	RS 485	Serial bus Differential receiver/transmitter
	B	RS 485	Serial bus Differential receiver/transmitter
	30	+24V	24V aux. input voltage Control power supply backup
	21	RO1	 Relay output 1 FAULT Programmable
	22	RO1	
	23	RO1	

Table 8-2: AI1 Configuration, When Programmed as DIN4

	Terminal	Signal	Description
	1	+10V _{ref}	Reference output Voltage for potentiometer, etc.
	2	AI1+ or DIN 4	Analog input, voltage range 0 – 10V DC Voltage/current input frequency reference Can be programmed as DIN4
	3	AI1-	I/O Ground Ground for reference and controls
	4	AI2+	Analog input, current range 0 – 20 mA Current input frequency reference
	5	AI2- /GND	
	6	+24V	Control voltage output
	7	GND	I/O ground Ground for reference and controls

Reference potentiometer
1 – 10 kΩ

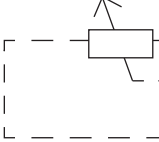
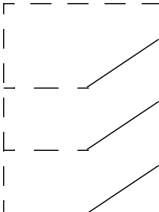
Table 8-3: Default I/O Configuration, All 230V, FR7 – FR8 460V and All 575V

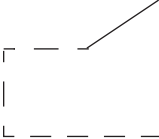
Terminal	Signal	Description
OPTA1		
1	+10V _{ref}	Reference output Voltage for potentiometer, etc.
2	AI1+	Analog input, voltage range 0 – 10V DC Voltage input frequency reference
3	AI1-	I/O Ground Ground for reference and controls
4	AI2+	Analog input, current range 0 – 20 mA Current input frequency reference
5	AI2-	
6	+24V ●	Control voltage output Voltage for switches. etc. max 0.1A
7 ●	GND	I/O ground Ground for reference and controls
8	DIN1	Start forward Contact closed = start forward
9	DIN2	Start reverse Contact closed = start reverse
10	DIN3	External fault input (programmable) Contact open = no fault Contact closed = fault
11	CMA	Common for DIN1 – DIN3 Connect to GND or +24V
12	+24V ●	Control voltage output Voltage for switches (see #6)
13 ●	GND	I/O ground Ground for reference and controls
14	DIN4	Multi-step speed select 1 DIN4 DIN5 Frequency ref. Open Open Ref. U _{in} Closed Open Multi-step ref.1 Open Closed Multi-step ref.2 Closed Closed RefMax
15	DIN5	
16	DIN6	
17	CMB	
18	AO1+	Output frequency Analog output Programmable Range 0 – 20 mA/R _L , max. 500Ω
19 ●	AO1-	
20	DO1	Digital output READY Programmable Open collector, I ≤ 50 mA, U ≤ 48V DC
OPTA2		
21	RO1	Relay output 1 RUN
22	RO1	
23	RO1	
24	RO2	Relay output 2 FAULT
25	RO2	
26	RO2	

October 2007

Parameter Lists

On the next pages you will find the lists of parameters within the respective parameter groups. The parameter descriptions are given in **Chapter 9**.

Column explanations:

Code	=	Location indication on the keypad; Shows the operator the present parameter number
Parameter	=	Name of parameter
Min.	=	Minimum value of parameter
Max.	=	Maximum value of parameter
Unit	=	Unit of parameter value; Given if available
Default	=	Value preset by factory
Cust	=	Customer's own setting
ID	=	ID number of the parameter (used with PC tools)
①	=	On the parameter code: parameter value can only be changed after the drive has been stopped.

Monitoring Values (Control Keypad: Menu M1)

The monitoring values are the actual values of parameters and signals as well as statuses and measurements. Monitoring values cannot be edited. See **Page 5-7** for more information.

Table 8-4: Monitoring Values

Code	Parameter	Unit	ID	Description
V1.1	Output frequency	Hz	1	Frequency to the motor
V1.2	Frequency reference	Hz	25	
V1.3	Motor speed	rpm	2	Calculated motor speed
V1.4	Motor current	A	3	Measured motor current
V1.5	Motor torque	%	4	Calculated actual torque/nom. torque of the motor
V1.6	Motor power	%	5	Calculated actual power/nom. power of the motor
V1.7	Motor voltage	V	6	Calculated motor voltage
V1.8	DC-link voltage	V	7	Measured DC-link voltage
V1.9	Unit temperature	°C	8	Heat sink temperature
V1.10	Analog input 1		13	AI1
V1.11	Analog input 2		14	AI2
V1.12	Analog output current	mA	26	AO1
V1.13	Analog output current 1, expander board	mA	31	
V1.14	Analog output current 2, expander board	mA	32	
V1.15	DIN1, DIN2, DIN3		15	Digital input statuses
V1.16	DIE1, DIE2, DIE3		33	I/O expander board: Digital input statuses
V1.17	RO1		34	Relay output 1 status
V1.18	ROE1, ROE2, ROE3		35	I/O exp. board: Relay output statuses
V1.19	DOE1		36	I/O exp. board: Digital output 1 status
V1.20	PID Reference	%	20	In percent of the maximum process reference
V1.21	PID Actual value	%	21	In percent of the maximum actual value
V1.22	PID Error value	%	22	In percent of the maximum error value
V1.23	PID Output	%	23	In percent of the maximum output value
V1.24	Autochange outputs 1, 2, 3		30	Used only in pump and fan control
V1.25	Mode		66	Shows current operation mode selected with start-up wizard: 0 = Not selected 1 = Standard 2 = Fan 3 = Pump 4 = High Performance

October 2007

Basic Parameters (Control Keypad: Menu P2 → P2.1)

Table 8-5: Basic Parameters P2.1

Code	Parameter	Min.	Max.	Unit	Default	Cust	ID	Note
P2.1.1	Min frequency	0.00	Par. 2.1.2	Hz	0.00		101	
P2.1.2	Max frequency	Par. 2.1.1	320.00	Hz	50.00		102	NOTE: If f_{max} > than the motor synchronous speed, check suitability for motor and drive system
P2.1.3	Acceleration time 1	0.1	3000.0	s	1.0		103	
P2.1.4	Deceleration time 1	0.1	3000.0	s	1.0		104	
P2.1.5	Current limit	$0.1 \times I_L$	$1.5 \times I_L$	A	I_L		107	NOTE: Consult the factory.
P2.1.6 ①	Nominal voltage of the motor	180	690	V	400V		110	
P2.1.7 ①	Nominal frequency of the motor	30.00	320.00	Hz	50.00		111	Check the rating plate of the motor
P2.1.8 ①	Nominal speed of the motor	300	20 000	rpm	1440		112	The default applies for a 4-pole motor and a nominal size drive.
P2.1.9 ①	Nominal current of the motor	$0.3 \times I_L$	$1.5 \times I_L$	A	I_L		113	Check the rating plate of the motor
P2.1.10 ①	Power factor	0.30	1.00		0.85		120	Check the rating plate of the motor
P2.1.11 ①	Start function	0	1		0		505	0 = Ramp 1 = Flying start
P2.1.12	Stop function	0	1		0		506	0 = Coasting 1 = Ramp
P2.1.13	VHz optimization	0	1		0		109	0 = Not used 1 = Automatic torque boost
P2.1.14	I/O reference	0	5		0		117	0 = AI1 1 = AI2 2 = Keypad reference 3 = Fieldbus reference (FBSpeedReference) 4 = Motor potentiometer 5 = AI1/AI2 selection
P2.1.15	AI2 signal range	1	4		2		390	Not used if AI2 Custom min <> 0% or AI2 custom max. <> 100% 1 = 0 – 20 mA 2 = 4 – 20 mA 3 = 0V – 10V 4 = 2V – 10V

Table 8-5: Basic Parameters P2.1, continued

Code	Parameter	Min.	Max.	Unit	Default	Cust	ID	Note
P2.1.16	Analog output function	0	12		1		307	<p>0 = Not used 1 = Output freq. ($0 - f_{max}$) 2 = Freq. reference ($0 - f_{max}$) 3 = Motor speed ($0 -$ Motor nominal speed) 4 = Output current ($0 - I_{nMotor}$) 5 = Motor torque ($0 - T_{nMotor}$) 6 = Motor power ($0 - P_{nMotor}$) 7 = Mot. voltage ($0 - V_{nMotor}$) 8 = DC-link volt ($0 - 1000V$) 9 = PI controller ref. value 10 = PI contr. act. value 1 11 = PI contr. error value 12 = PI controller output</p>
P2.1.17 ^①	DIN2 function	0	10		1		319	<p>0 = Not used 1 = Start Reverse (DIN1 = Start forward) 2 = Reverse (DIN1 = Start) 3 = Stop pulse (DIN1 = Start pulse) 4 = External fault, cc 5 = External fault, oc 6 = Run enable 7 = Preset speed 2 8 = Motor pot. UP (cc) 9 = Disable PID (Direct freq. reference) 10 = Interlock 1</p>
P2.1.18 ^①	DIN3 function	0	17		6		301	<p>0 = Not used 1 = Reverse 2 = External fault, cc 3 = External fault, oc 4 = Fault reset 5 = Run enable 6 = Preset speed 1 7 = Preset speed 2 8 = DC-braking command 9 = Motor pot. UP (cc) 10 = Motor pot. DOWN (cc) 11 = Disable PID (Direct freq. reference) 12 = PID Keypad ref. 2 selection 13 = Interlock 2 14 = Thermistor input Note! See Page 4-9 15 = Force control place to I/O 16 = Force control place to Fieldbus 17 = AI1/AI2 selection for I/O reference</p>

October 2007

Table 8-5: Basic Parameters P2.1, continued

Code	Parameter	Min.	Max.	Unit	Default	Cust	ID	Note
P2.1.19	Preset speed 1	0.00	Par. 2.1.2	Hz	10.00		105	
P2.1.20	Preset speed 2	0.00	Par. 2.1.2	Hz	50.00		106	
P2.1.21	Automatic restart	0	1		0		731	0 = Not used 1 = Used
P2.1.22	Parameter conceal	0	1		0		115	0 = All parameters and menus visible 1 = Only group P2.1 and menus M1 to H5 visible

Input Signals (Control Keypad: Menu P2 → P2.2)

Table 8-6: Input Signals, P2.2

Code	Parameter	Min.	Max.	Unit	Default	Cust	ID	Note
P2.2.1 ①	Expander board DIE1 function	0	13		7		368	0 = Not used 1 = Reverse 2 = External fault, cc 3 = External fault, oc 4 = Fault reset 5 = Run enable 6 = Preset speed 1 7 = Preset speed 2 8 = DC-braking command 9 = Motor pot. UP (cc) 10 = Motor pot. DOWN (cc) 11 = Disable PID (PID control selection) 12 = PID Keypad ref. 2 selection 13 = Interlock 1
P2.2.2 ①	Expander board DIE2 function	0	13		4		330	Same as parameter 2.2.1, except: 13 = Interlock 2
P2.2.3 ①	Expander board DIE3 function	0	13		11		369	Same as parameter 2.2.1, except: 13 = Interlock 3
P2.2.4	DIN4 function (AI1)	0	13		2		499	Used if P2.2.6 = 0 Selections same as in parameter 2.2.3
P2.2.5	AI1 signal selection	0			10		377	10 = AI1 (1 = Local, 0 = input 1) 11 = AI2 (1 = Local, 1 = input 2) 20 = Exp. AI1 (2 = exp. board, 0 = input 1) 21 = Exp AI2 (2 = exp. board, 1 = input 2)
P2.2.6	AI1 signal range	1	4		3		379	0 = Digital input 4 1 = 0 – 20 mA 2 = 4 – 20 mA 3 = 0 – 10V 4 = 2 – 10V Not used if AI2 Custom min > 0% or AI2 custom max. < 100% Note! See Page 5-22

Table 8-6: Input Signals, P2.2, continued

Code	Parameter	Min.	Max.	Unit	Default	Cust	ID	Note
P2.2.7	AI1 custom minimum setting	0.00	100.00	%	0.00		380	
P2.2.8	AI1 custom maximum setting	0.00	100.00	%	100.00		381	
P2.2.9	AI1 inversion	0	1		0		387	0 = Not inverted 1 = Inverted
P2.2.10	AI1 filter time	0.00	10.00	s	0.10		378	0 = No filtering
P2.2.11	AI2 signal selection	0			11		388	Same as parameter 2.2.5
P2.2.12	AI2 signal range	1	4		2		390	Not used if AI2 Custom min <> 0% or AI2 custom max. <> 100% 1 = 0 – 20 mA 2 = 4 – 20 mA 3 = 0V – 10V 4 = 2V – 10V
P2.2.13	AI2 custom minimum setting	0.00	100.00	%	0.00		391	
P2.2.14	AI2 custom maximum setting	0.00	100.00	%	100.00		392	
P2.2.15	AI2 inversion	0	1		0		398	0 = Not inverted 1 = Inverted
P2.2.16	AI2 filter time	0.00	10.00	s	0.10		389	0 = No filtering
P2.2.17	Motor potentiometer frequency reference memory reset	0	2		1		367	0 = No reset 1 = Reset if stopped or powered down 2 = Reset if powered down
P2.2.18	Reference scaling minimum value	0.00	P2.2.19		0.00		344	Does not affect the fieldbus reference (Scaled between par. 2.1.1 and par. 2.1.2)
P2.2.19	Reference scaling maximum value	P2.2.18	320.00		0.00		345	Does not affect the fieldbus reference (Scaled between par. 2.1.1 and par. 2.1.2)
P2.2.20	Keypad control reference selection	0	5		2		121	0 = AI1 1 = AI2 2 = Keypad reference 3 = Fieldbus reference (FBspeedreference) 4 = Motor potentiometer 5 = PID controller
P2.2.21	Fieldbus control reference selection	0	5		3		122	See above

October 2007

Output Signals (Control Keypad: Menu P2 → P2.3)

Table 8-7: Output Signals, G2.3

Code	Parameter	Min.	Max.	Unit	Default	Cust	ID	Note
P2.3.1	Relay output 1 function	0	20		3		313	0 = Not used 1 = Ready 2 = Run 3 = Fault 4 = Fault inverted 5 = FC overheat warning 6 = Ext. fault or warning 7 = Ref. fault or warning 8 = Warning 9 = Reversed 10 = Preset speed 11 = At speed 12 = Mot. regulator active 13 = OP freq. limit superv. 1 14 = Control place: IO 15 = Thermistor fault/ warning 16 = Actual value supervision 17 = Autochange 1 control 18 = Autochange 2 control 19 = Autochange 3 control 20 = AI supervision
P2.3.2	Expander board relay output 1 function	0	19		2		314	Same as parameter 2.3.1
P2.3.3	Expander board relay output 2 function	0	19		3		317	Same as parameter 2.3.1
P2.3.4	Expander board digital output 1 function	0	19		1		312	Same as parameter 2.3.1
P2.3.5	Analog output function	0	12		1		307	See parameter 2.1.16
P2.3.6	Analog output filter time	0.00	10.00	s	1.00		308	0 = No filtering
P2.3.7	Analog output inversion	0	1		0		309	0 = Not inverted 1 = Inverted
P2.3.8	Analog output minimum	0	1		0		310	0 = 0 mA 1 = 4 mA
P2.3.9	Analog output scale	10	1000	%	100		311	
P2.3.10	Expander board analog output 1 function	0	12		0		472	Same as parameter 2.1.16
P2.3.11	Expander board analog output 2 function	0	12		0		479	Same as parameter 2.1.16
P2.3.12	Output frequency limit 1 supervision	0	2		0		315	0 = No limit 1 = Low limit supervision 2 = High limit supervision
P2.3.13	Output frequency limit 1; Supervised value	0.00	Par. 2.1.2	Hz	0.00		316	

Table 8-7: Output Signals, G2.3, continued

Code	Parameter	Min.	Max.	Unit	Default	Cust	ID	Note
P2.3.14	Analog input supervision	0	2		0		356	0 = Not used 1 = AI1 2 = AI2
P2.3.15	AI supervision OFF limit	0.00	100.00	%	10.00		357	
P2.3.16	AI supervision ON limit	0.00	100.00	%	90.00		358	
P2.3.17	Relay output 1 ON delay	0.00	320.00	s	0.00		487	ON delay for RO1
P2.3.18	Relay output 1 OFF delay	0.00	320.00	s	0.00		488	OFF delay for RO1

Drive Control Parameters (Control Keypad: Menu P2 → P2.4)**Table 8-8: Drive Control Parameters, P2.4**

Code	Parameter	Min.	Max.	Unit	Default	Cust	ID	Note
P2.4.1	Ramp 1 shape	0.0	10.0	s	0.0		500	0 = Linear >0 = S-curve ramp time
P2.4.2 [Ⓢ]	Brake chopper	0	3		0		504	0 = Disabled 1 = Used in Run state 3 = Used in Run and Stop state
P2.4.3	DC braking current	0.15 × I _n	1.5 × I _n	A	Varies		507	
P2.4.4	DC braking time at stop	0.00	600.00	s	0.00		508	0 = DC brake is off at stop
P2.4.5	Frequency to start DC braking during ramp stop	0.10	10.00	Hz	1.50		515	
P2.4.6	DC braking time at start	0.00	600.00	s	0.00		516	0 = DC brake is off at start
P2.4.7	Flux brake	0	1		0		520	0 = Off 1 = On
P2.4.8	Flux braking current	0.0	Varies	A	0.0		519	

Prohibit Frequency Parameters (Control Keypad: Menu P2 → P2.5)**Table 8-9: Prohibit Frequency Parameters, P2.5**

Code	Parameter	Min.	Max.	Unit	Default	Cust	ID	Note
P2.5.1	Prohibit frequency range 1 low limit	0.0	Par. 2.5.2	Hz	0.0		509	0 = Not used
P2.5.2	Prohibit frequency range 1 high limit	0.0	Par. 2.1.2	Hz	0.0		510	0 = Not used
P2.5.3	Prohibit frequencies acc./dec. ramp scaling	0.1	10.0	times	1.0		518	Multiplier of the currently selected ramp time between prohibit frequency limits

October 2007

Motor Control Parameters (Control Keypad: Menu P2 → P2.6)

Table 8-10: Motor Control Parameters, P2.6

Code	Parameter	Min.	Max.	Unit	Default	Cust	ID	Note
P2.6.1 ①	Motor control mode	0	1		0		600	0 = Frequency control 1 = Speed control
P2.6.2 ①	VHz ratio selection	0	3		0		108	0 = Linear 1 = Squared 2 = Programmable 3 = Linear with flux optim.
P2.6.3 ①	Field weakening point	30.00	320.00	Hz	50.00		602	
P2.6.4 ①	Voltage at field weakening point	10.00	200.00	%	100.00		603	$n\% \times U_{nmot}$
P2.6.5 ①	VHz curve midpoint frequency	0.00	par. P2.6.3	Hz	50.00		604	
P2.6.6 ①	VHz curve midpoint voltage	0.00	100.00	%	100.00		605	$n\% \times U_{nmot}$ Parameter max. value = par. 2.6.4
P2.6.7 ①	Output voltage at zero frequency	0.00	40.00	%	0.00		606	$n\% \times U_{nmot}$
P2.6.8	Switching frequency	1.0	16.0	kHz	6.0		601	Depends on hp
P2.6.9	Overvoltage controller	0	1		1		607	0 = Not used 1 = Used
P2.6.10	Undervoltage controller	0	1		1		608	0 = Not used 1 = Used
P2.6.11	Identification	0	1		0		631	0 = No action 1 = ID no run

Protections (Control Keypad: Menu P2 → P2.7)

Table 8-11: Protections, P2.7

Code	Parameter	Min.	Max.	Unit	Default	Cust	ID	Note
P2.7.1	Response to 4 mA reference fault	0	3		0		700	0 = No response 1 = Warning 2 = Fault, stop acc. to 2.1.12 3 = Fault, stop by coasting
P2.7.2	Response to external fault	0	3		2		701	0 = No response 1 = Warning 2 = Fault, stop acc. to 2.1.12 3 = Fault, stop by coasting
P2.7.3	Response to undervoltage fault	1	3		2		727	
P2.7.4	Output phase supervision	0	3		2		702	
P2.7.5	Ground fault protection	0	3		2		703	
P2.7.6	Thermal protection of the motor	0	3		2		704	
P2.7.7	Motor ambient temperature factor	-100.0	100.0	%	0.0		705	

Table 8-11: Protections, P2.7, continued

Code	Parameter	Min.	Max.	Unit	Default	Cust	ID	Note
P2.7.8	Motor cooling factor at zero speed	0.0	150.0	%	40.0		706	
P2.7.9	Motor thermal time constant	1	200	min	45		707	
P2.7.10	Motor duty cycle	0	100	%	100		708	
P2.7.11	Stall protection	0	3		1		709	Same as parameter 2.7.1
P2.7.12	Stall current limit	0.1	$I_{n\text{motor}} \times 2$	A	$I_{n\text{motor}} \times 1.3$		710	
P2.7.13	Stall time limit	1.00	120.00	s	15.00		711	
P2.7.14	Stall frequency limit	1.0	P2.1.2	Hz	25.0		712	
P2.7.15	Underload protection	0	3		0		713	Same as parameter 2.7.1
P2.7.16	Underload curve at nominal frequency	10.0	150.0	%	50.0		714	
P2.7.17	Underload curve at zero frequency	5.0	150.0	%	10.0		715	
P2.7.18	Underload protection time limit	2.00	600.00	s	20.00		716	
P2.7.19	Response to thermistor fault	0	3		2		732	Same as parameter 2.7.1
P2.7.20	Response to fieldbus fault	0	3		2		733	Same as parameter 2.7.1
P2.7.21	Response to slot fault	0	3		2		734	Same as parameter 2.7.1
P2.7.22	Actual value supervision	0	4		0		735	0 = No response 1 = Warning if below limit 2 = Warning if above limit 3 = Fault, if below limit 4 = Fault, if above limit
P2.7.23	Actual value supervision limit	0.0	100.0	%	10.0		736	
P2.7.24	Actual value supervision delay	0	3600	s	5		737	

Autorestart Parameters (Control Keypad: Menu P2 → P2.8)**Table 8-12: Autorestart Parameters, P2.8**

Code	Parameter	Min.	Max.	Unit	Default	Cust	ID	Note
P2.8.1	Wait time	0.10	10.00	s	0.50		717	
P2.8.2	Trial time	0.00	60.00	s	30.00		718	
P2.8.3	Start function	0	2		0		719	0 = Ramp 1 = Flying start 2 = According to par. 2.4.6

October 2007

PID Reference Parameters (Control Keypad: Menu P2 → P2.9)

Table 8-13: PID Reference Parameters, P2.9

Code	Parameter	Min.	Max.	Unit	Default	Cust	ID	Note
P2.9.1	PID activation	0	1		0		163	0 = Not used 1 = PID controller activated 2 = Pump & fan control active, group P2.10 visible
P2.9.2	PID reference	0	3		2		332	0 = AI1 1 = AI2 2 = Ref. from keypad (PID Ref 1) 3 = Fieldbus reference (ProcessDataIN1)
P2.9.3	Actual value input	0	6		1		334	0 = AI1 signal 1 = AI2 signal 2 = Fieldbus (ProcessDataIN2) 3 = Motor torque 4 = Motor speed 5 = Motor current 6 = Motor power
P2.9.4	PID controller gain	0.0	1000.0	%	100.0		118	
P2.9.5	PID controller I-time	0.00	320.00	s	10.00		119	
P2.9.6	PID controller D-time	0.00	10.00	s	0.00		132	
P2.9.7	Actual value 1 minimum scale	-1000.0	1000.0	%	0.00		336	0 = No minimum scaling
P2.9.8	Actual value 1 maximum scale	-1000.0	1000.0	%	100.0		337	100 = No maximum scaling
P2.9.9	Error value inversion	0	1		0		340	
P2.9.10	Sleep frequency	Par. 2.1.1	Par. 2.1.2	Hz	10.00		1016	
P2.9.11	Sleep delay	0	3600	s	30		1017	
P2.9.12	Wake up level	0.00	100.00	%	25.00		1018	
P2.9.13	Wake up function	0	3		0		1019	0 = Wake-up at fall below wake-up level (2.9.12) 1 = Wake-up at exceeded wake-up level (2.9.12) 2 = Wake-up at fall below wake-up level (PID ref) 3 = Wake-up at exceeded wake-up level (PID ref)

Pump and Fan Control Parameters (Control Keypad: Menu P2 → P2.10)

Note: Group P2.10 is visible only if the value of par 2.9.1 is set to 2.

Table 8-14: Pump and Fan Control Parameters, P2.10

Code	Parameter	Min.	Max.	Unit	Default	Cust	ID	Note
P2.10.1	Number of auxiliary drives	0	3		1		1001	
P2.10.2	Start delay, auxiliary drives	0.0	300.0	s	4.0		1010	
P2.10.3	Stop delay, auxiliary drives	0.0	300.0	s	2.0		1011	
P2.10.4	Autochange	0	4		0		1027	0 = Not used 1 = Autochange with aux pumps 2 = Autochange with drive & aux pumps 3 = Autochange and interlocks (aux pumps) 4 = Autochange and interlocks (drive & aux pumps)
P2.10.5	Autochange interval	0.0	3000.0	h	48.0		1029	0.0 = TEST = 40 s Elapsed time for autochange
P2.10.6	Autochange; Maximum number of auxiliary drives	0	3		1		1030	Autochange level for auxiliary drives
P2.10.7	Autochange frequency limit	0.00	par. 2.1.2	Hz	25.00		1031	Autochange frequency level for variable speed drive
P2.10.8	Start frequency, auxiliary drive 1	Par. 2.10.9	320.00	Hz	51.00		1002	
P2.10.9	Stop frequency, auxiliary drive 1	Par. 2.1.1	Par. 2.10.8	Hz	10.00		1003	

Keypad Control (Control Keypad: Menu K3)

The parameters for the selection of control place and direction on the keypad are listed in **Table 8-15**. See the Keypad Control Menu on **Page 5-10**.

Table 8-15: Keypad Control Parameters, K3

Code	Parameter	Min.	Max.	Unit	Default	Cust	ID	Note
P3.1	Control place	1	3		1		125	1 = I/O terminal 2 = Keypad 3 = Fieldbus
R3.2	Keypad reference	Par. 2.1.1	Par. 2.1.2	Hz				
P3.3	Direction (on keypad)	0	1		0		123	0 = Forward 1 = Reverse
R3.4	Stop button	0	1		1		114	0 = Limited function of Stop button 1 = Stop button always enabled
R3.5	PID reference	0.00	100.00	%	0.00			
R3.6	PID reference 2	0.00	100.00	%	0.00			Selected with digital inputs

October 2007

System Menu (Control Keypad: Menu S6)

For parameters and functions related to the general use of the drive, such as customized parameter sets or information about the hardware and software, see **Page 5-13**.

Expander Boards (Control Keypad: Menu E7)

The E7 menu shows the expander boards attached to the control board and board-related information. For more information, see **Page 5-26**.

October 2007

Chapter 9 — Description of Parameters

Basic Parameters

- | | | |
|---------------|--|-------|
| 2.1.1 | Minimum frequency | ID101 |
| 2.1.2 | Maximum frequency | ID102 |
| | Defines the frequency limits of the drive. The maximum value for parameters 2.1.1 and 2.1.2 is 320 Hz.
The software will automatically check the values of parameters 2.1.19, 2.1.20, 2.3.13, 2.5.1, 2.5.5 and 2.6.5. | |
| 2.1.3 | Acceleration time 1 | ID103 |
| 2.1.4 | Deceleration time 1 | ID104 |
| | These limits correspond to the time required for the output frequency to accelerate from the zero frequency to the set maximum frequency (par. 2.1.2). | |
| 2.1.5 | Current limit | ID107 |
| | This parameter determines the maximum motor current from the drive. To avoid motor overload, set this parameter according to the rated current of the motor. The current limit is equal to the rated converter current (I_L) by default. | |
| 2.1.6 | Nominal voltage of the motor | ID110 |
| | Find this value V_n on the motor nameplate. This parameter sets the voltage at the field weakening point (parameter 2.6.4) to $100\% \times U_{n\text{motor}}$. | |
| 2.1.7 | Nominal frequency of the motor | ID111 |
| | Find this value f_n on the motor nameplate. This parameter sets the field weakening point (parameter 2.6.3) to the same value. | |
| 2.1.8 | Nominal speed of the motor | ID112 |
| | Find this value n_n on the motor nameplate. | |
| 2.1.9 | Nominal current of the motor | ID113 |
| | Find this value I_n on the motor nameplate. | |
| 2.1.10 | Power Factor | ID120 |
| | Find this value on the motor nameplate. | |

2.1.11 Start function

ID505

Ramp:

- 0** The drive starts from 0 Hz and accelerates to maximum frequency within the set acceleration time. (Load inertia or starting friction may cause prolonged acceleration times).

Flying start:

- 1** The drive is able to start into a running motor by applying a small torque to motor and searching for the frequency corresponding to the speed the motor is running at. Searching starts from the maximum frequency towards the actual frequency until the correct value is detected. Thereafter, the output frequency will be increased/decreased to the set reference value according to the set acceleration/deceleration parameters.

Use this mode if the motor is coasting when the start command is given. With the flying start, it is possible to ride through short utility voltage interruptions.

2.1.12 Stop function

ID506

Coasting:

- 0** The motor coasts to a halt without control from the drive after the Stop command.

Ramp:

- 1** After the Stop command, the speed of the motor is decelerated according to the set deceleration parameters.
If the regenerated energy is high it may be necessary to use an external braking resistor for faster deceleration.

2.1.13 V/Hz optimization

ID109

- 0** Not used

- 1** Automatic torque boost

The voltage to the motor changes automatically which makes the motor produce sufficient torque to start and run at low frequencies. The voltage increase depends on the motor type and power. Automatic torque boost can be used in applications where starting torque due to starting friction is high, e.g. in conveyors.

Note: In high torque — low speed applications — it is likely that the motor will overheat. If the motor has to run a prolonged time under these conditions, special attention must be paid to cooling the motor. Use external cooling for the motor if the temperature tends to rise too high.

October 2007

2.1.14 I/O Reference selection ID117

Defines the selected frequency reference source when the drive is controlled from the I/O terminal.

- 0 AI1 reference (terminals 2 and 3, e.g. potentiometer)
- 1 AI2 reference (terminals 5 and 6, e.g. transducer)
- 2 Keypad reference (parameter R3.2)
- 3 Reference from Fieldbus (FBSpeedReference)
- 4 Motor potentiometer reference
- 5 AI1/AI2 selection. Selection of AI2 is made programmable by DIN3 Function (P2.1.18)

2.1.15 AI2 (I_{in}) signal range ID390

- 1 Signal range 0 – 20 mA
- 2 Signal range 4 – 20 mA
- 3 Signal range 0 – 10V
- 4 Signal range 2 – 10V

Note: The selections have no effect if par. 2.2.12 > 0%, or par. 2.2.13 < 100%.

2.1.16 Analog output function ID307

This parameter selects the desired function for the analog output signal. See **Table 8-5** for the parameter values.

2.1.17 DIN2 function

ID319

This parameter has 10 selections. If digital input DIN2 is not used, set the parameter value to 0.

- | | |
|-----------|---|
| 1 | Start reverse |
| 2 | Reverse |
| 3 | Stop pulse |
| 4 | External fault
Contact closed: Fault is displayed and motor stopped when the input is active |
| 5 | External fault
Contact open: Fault is displayed and motor stopped when the input is not active |
| 6 | Run enable
Contact open: Start of motor disabled
Contact closed: Start of motor enabled
Coast stop if dropped during RUN |
| 7 | Preset speed 2 |
| 8 | Motor potentiometer UP
Contact closed: Reference increases until the contact is opened. |
| 9 | Disable the PID-controller (Direct frequency reference) |
| 10 | Interlock 1 (can only be selected when pump and fan control is active, P2.9.1=2) |

October 2007

2.1.18 DIN3 function

ID301

The parameter has 13 selections. If digital input DIN3 is not used, set the parameter value to 0.

- | | |
|----|---|
| 1 | Reverse
Contact open: Forward
Contact closed: Reverse |
| 2 | External fault
Contact closed: Fault is displayed and motor stopped when the input is active |
| 3 | External fault
Contact open: Fault is displayed and motor stopped when the input is not active |
| 4 | Fault reset
Contact closed: All faults reset |
| 5 | Run enable
Contact open: Start of motor disabled
Contact closed: Start of motor enabled
Coast stop if dropped during RUN |
| 6 | Preset speed 1 |
| 7 | Preset speed 2 |
| 8 | DC braking command
Contact closed: In Stop mode, the DC braking operates until the contact is opened. DC-braking current is about 10% of the value selected with par. 2.4.3. |
| 9 | Motor potentiometer UP
Contact closed: Reference increases until the contact is opened. |
| 10 | Motor potentiometer DOWN.
Contact closed: Reference decreases until the contact is opened |
| 11 | Disable the PID-controller (Direct frequency reference) |
| 12 | PID Keypad reference 2 selection |
| 13 | Interlock 2 (can only be selected when pump and fan control is active, P2.9.1=2) |
| 14 | Thermistor input (See Page 4-9) |
| 15 | Force control place to I/O |
| 16 | Force control place to Fieldbus |
| 17 | AI1/AI2 selection for I/O Reference (par 2.1.14) |

2.1.19 Preset speed 1

ID105

2.1.20 Preset speed 2

ID106

Parameter values are automatically limited between the minimum and maximum frequencies (par. 2.1.1 and 2.1.2).

2.1.21 Automatic restart function ID731

The automatic restart is taken into use with this parameter.

- 0** Disable
- 1** Enabled (3 automatic restarts, see par. 2.8.1 – 2.8.3)

2.1.22 Parameter conceal ID115

With this parameter you can hide all other parameter groups except the basic parameter group (B2.1).

The factory default of this parameter is 0.

- 0** Disabled (all parameter groups can be browsed with the keypad)
- 1** Enabled (only the basic parameters, B2.1, can be browsed with the keypad)

Input Signals

2.2.1 Expander board DIE1 function ID368

This parameter has 12 selections. If the expander board digital input DIN1 is not used, set the parameter value to 0.

Selections are the same as in parameter 2.1.18, except:

- 13** Interlock 1

2.2.2 Expander board DIE2 function ID330

The selections are the same as in parameter 2.2.1, except:

- 13** Interlock 2

2.2.3 Expander board DIE3 function ID369

The selections are the same as in parameter 2.2.1, except:

- 13** Interlock 3

2.2.4 DIN4 Function ID499

If the value of par. 2.2.6 is set to 0, AI1 functions as digital input 4.

The selections are the same as in parameter 2.2.3.

Note: If you program the analog input as DIN4, check that the jumper selections are correct (see **Figure 9-1**).

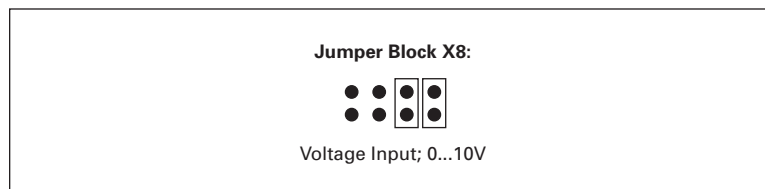

Figure 9-1: Jumper Selections of X4/X8 When AI1 Functions as DIN4

October 2007

2.2.5 AI1 signal selection

ID377

Connect the AI1 signal to the analog input of your choice with this parameter.

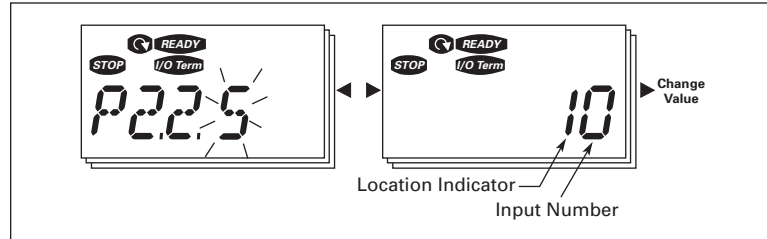

Figure 9-2: AI1 Signal Selection

The value of this parameter is built from the board indicator and the respective input terminal number. See **Figure 9-2** above.

- | | |
|-------------------|-------------------------|
| Board indicator 1 | = Local inputs |
| Board indicator 2 | = Expander board inputs |
| Input number 0 | = Input 1 |
| Input number 1 | = Input 2 |
| Input number 2 | = Input 3 |
| — | |
| — | |
| Input number 9 | = Input 10 |

Example:

If you set the value of this parameter to **10**, you have selected the local input **1** for the AI1 signal. Again, if the value is set to **21**, the expander board input **2** has been selected for the AI1 signal.

If you want to use the values of analog input signal for testing purposes only, you can set the parameter value to **0 – 9**. In this case, value **0** corresponds to **0%**, value **1** corresponds to **20%** and any value between **2** and **9** corresponds to **100%**.

2.2.6 AI1 signal range ID379

With this parameter you can select the AI1 signal range.

0	DIN 4
1	Signal range 0 – 20 mA
2	Signal range 4 – 20 mA
3	Signal range 0 – 10V
4	Signal range 2 – 10V

Note: The selections have no effect if par. 2.2.7 > 0%, or par. 2.2.8 < 100%.

If the value of par. 2.2.6 is set to 0, AI1 functions as digital input 4. See par. 2.2.4.

2.2.7 AI1 custom setting minimum ID380**2.2.8 AI1 custom setting maximum** ID381

Set the custom minimum and maximum levels for the AI1 signal within 0 – 10V.

2.2.9 AI1 signal inversion ID387

By setting the parameter value to 1 the AI1 signal inversion takes place.

2.2.10 AI1 signal filter time ID378

This parameter, given a value greater than 0, activates the function that filters out disturbances from the incoming analog V_{in} signal.

Long filtering time makes the regulation response slower. See **Figure 9-3**.

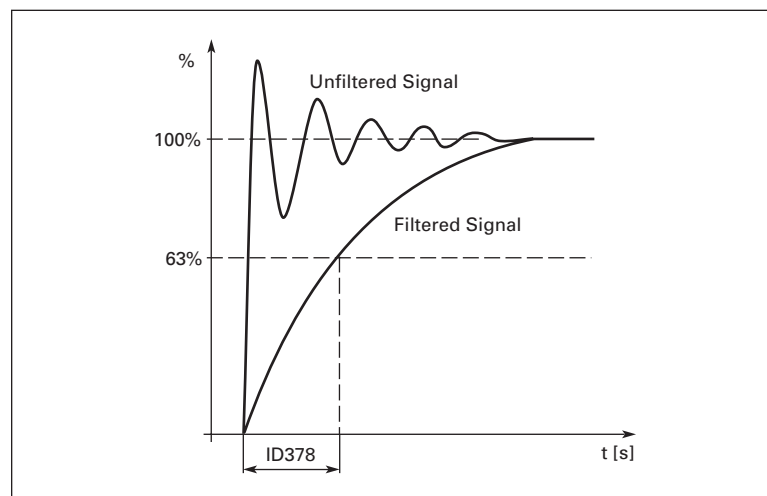

Figure 9-3: AI1 Signal Filtering

2.2.11 AI2 signal selection ID388

Connect the AI2 signal to the analog input of your choice with this parameter. See par. 2.2.5 for the value setting procedure.

October 2007

2.2.12 AI2 signal range ID390

- 1 Signal range 0 – 20 mA
- 2 Signal range 4 – 20 mA
- 3 Signal range 0 – 10V
- 4 Signal range 2 – 10V

Note: The selections have no effect if par. 2.2.13 > 0%, or par. 2.2.14 < 100%.

2.2.13 AI2 custom minimum ID391**2.2.14 AI2 custom maximum** ID392

These parameters allow you to scale the input current signal between 0 and 20 mA. Similar to parameters 2.2.7 and 2.2.8.

2.2.15 Analog input AI2 signal inversion ID398

See corresponding parameter 2.2.9.

2.2.16 Analog input AI2 signal filter time ID389

See corresponding parameter 2.2.10.

2.2.17 Motor potentiometer memory reset (Frequency reference) ID367

- 0 No reset
- 1 Memory reset in stop and powerdown
- 2 Memory reset in powerdown

- 2.2.18 Reference scaling minimum value** ID344
2.2.19 Reference scaling maximum value ID345

You can choose a scaling range for the frequency reference between the Minimum and Maximum frequency. If no scaling is desired set the parameter value to 0.

In **Figure 9-4**, voltage input AI1 with signal range 0 – 10V is selected for reference.

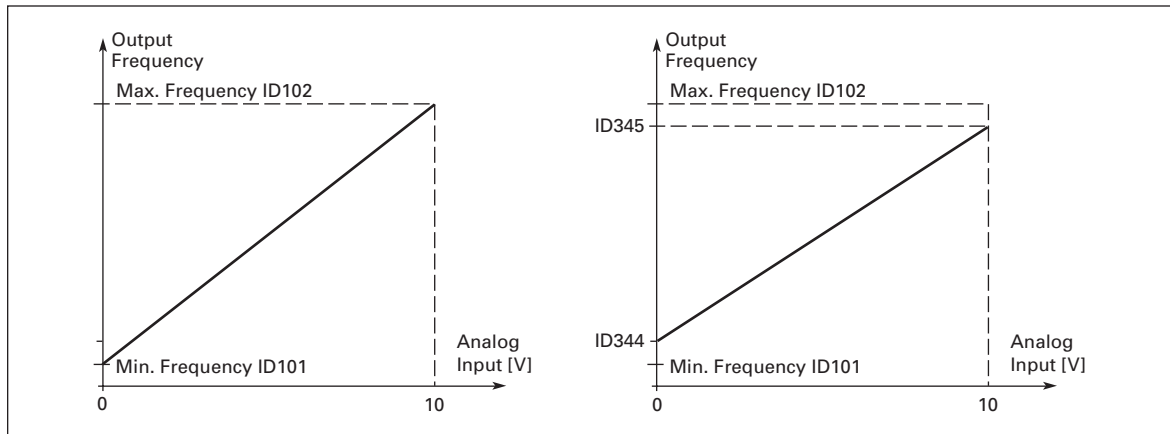

Figure 9-4: Without (Left) and With (Right) Reference Scaling

- 2.1.20 Keypad frequency reference selection** ID121

Defines the selected reference source when the drive is controlled from the keypad.

- 0** AI1 reference (by default AI1, terminals 2 and 3, e.g. potentiometer)
- 1** AI2 reference (by default AI2, terminals 5 and 6, e.g. transducer)
- 2** Keypad reference (parameter 3.2)
- 3** Reference from Fieldbus (FBSpeedReference)
- 4** Motor potentiometer reference
- 5** PID-controller reference

- 2.2.21 Fieldbus frequency reference selection** ID122

Defines the selected reference source when the drive is controlled from the fieldbus. For the parameter values, see par. 2.2.20.

Output Signals

- 2.3.1 Relay output 1 function** ID313
- 2.3.2 Expander board relay output 1 function** ID314
- 2.3.3 Expander board relay output 2 function** ID317
- 2.3.4 Expander board digital output 1 function** ID312

October 2007

Table 9-1: Output Signals via RO1 and Expander Board RO1, RO2 and DO1

Setting value	Signal content
0 Not used	Out of operation
Relay output RO1 and expander board programmable relays (RO1, RO2) are activated when:	
1 Ready	The drive is ready to operate
2 Run	The drive operates (motor is running)
3 Fault	A fault trip has occurred
4 Fault inverted	A fault trip not occurred
5 Drive overheat warning	The heatsink temperature exceeds +70°C
6 External fault or warning	Fault or warning depending on par. 2.7.2
7 Reference fault or warning	Fault or warning depending on par. 2.7.1 – if analog reference is 4 – 20 mA and signal is <4 mA
8 Warning	Always if a warning exists
9 Reversed	The reverse command has been selected
10 Preset speed	A preset speed has been selected
11 At speed	The output frequency has reached the set reference
12 Motor regulator activated	Overvoltage or overcurrent regulator was activated
13 Output frequency limit 1 supervision	The output frequency goes outside the set supervision low limit/high limit (see parameters 2.3.12 and 2.3.13 below)
14 Control from I/O terminals	Selected control place (Menu K3; par. 3.1) is "I/O terminal"
15 Thermistor fault or warning	The thermistor input of option board indicates overtemperature. Fault or warning depending on parameter 2.7.19.
16 Actual value supervision active	Parameters 2.7.22 – 2.7.24
17 Autochange 1 control	Pump 1 control, parameters 2.10.1 – 2.10.7
18 Autochange 2 control	Pump 2 control, parameters 2.10.1 – 2.10.7
19 Autochange 3 control	Pump 3 control, parameters 2.10.1 – 2.10.7
20 AI supervision	The relay energizes according to settings of parameters 2.3.14 – 2.3.16.

2.3.5 Analog output function ID307

This parameter selects the desired function for the analog output signal.
See **Table 8-5** for the parameter values.

2.3.6 Analog output filter time ID308

Defines the filtering time of the analog output signal.
If you set value 0 for this parameter, no filtering takes place.

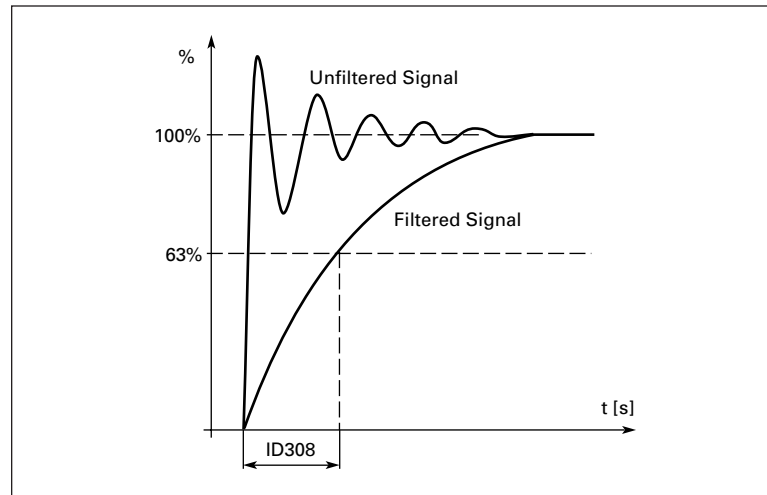

Figure 9-5: Analog Output Filtering

October 2007

2.3.7 Analog output invert ID309

Inverts the analog output signal:

Maximum output signal = 0 %

Minimum output signal = Maximum set value (parameter 2.3.9)

0 Not inverted**1** Inverted

See parameter 2.3.9 below.

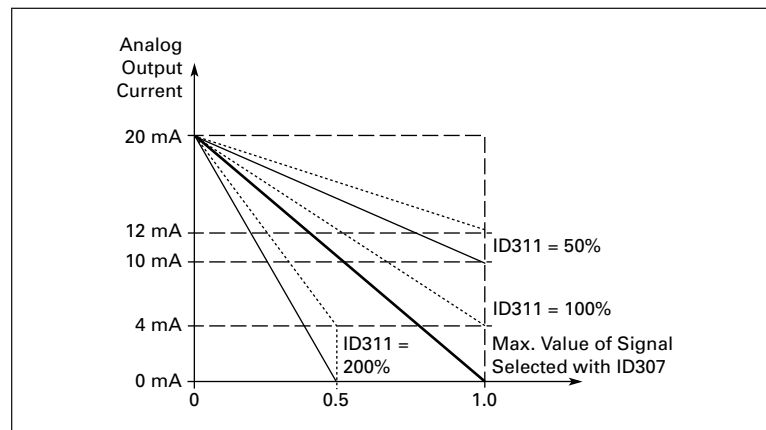
**Figure 9-6: Analog Output Invert****2.3.8 Analog output minimum** ID310

Sets the signal minimum to either 0 mA or 4 mA (living zero). Note the difference in the analog output scaling in parameter 2.3.9.

2.3.9 Analog output scale ID311

Scaling factor for the analog output.

Table 9-2: Analog Output Scaling

Signal	Max. value of the signal
Output frequency	100% x f_{max}
Motor speed	100% x Motor nom. speed
Output current	100% x I_{nMotor}
Motor torque	100% x T_{nMotor}
Motor power	100% x P_{nMotor}
Motor voltage	100% x V_{nMotor}
DC-link voltage	1000 V
PI-ref. value	100% x ref. value max.
PI act. value 1	100% x actual value max.
PI error value	100% x error value max.
PI output	100% x output max.

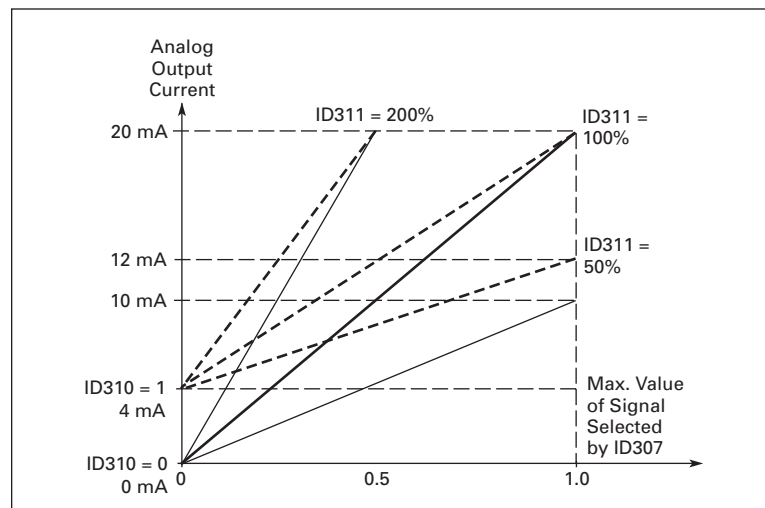
**Figure 9-7: Analog Output Scaling**

2.3.10 Expander board analog output 1 function ID472

2.3.11 Expander board analog output 2 function ID479

These parameters select the desired functions for the expander board analog output signals. See par. 2.1.16 for the parameter values.

2.3.12 Output frequency limit 1 supervision function ID315

- 0** No supervision
- 1** Low limit supervision
- 2** High limit supervision

If the output frequency goes under/over the set limit (par. 2.3.13) this function generates a warning message via the relay outputs depending on the settings of parameters 2.3.1 – 2.3.4.

2.3.13 Output frequency limit 1 supervised value ID316

Selects the frequency value supervised by parameter 2.3.12.

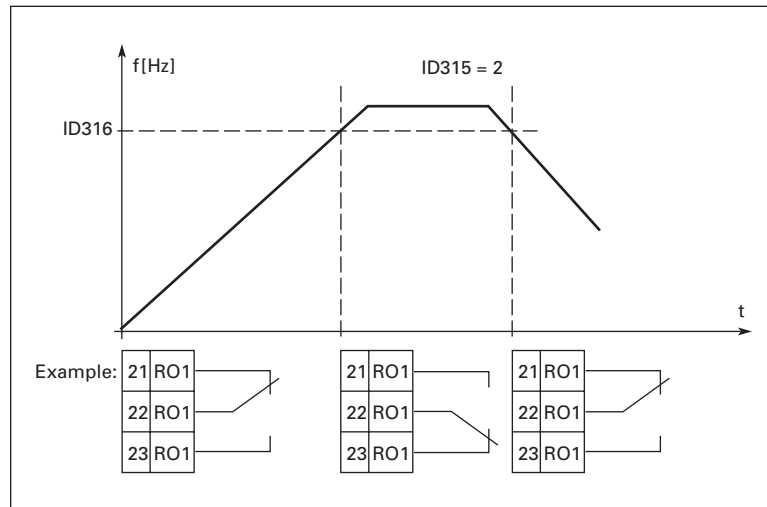

Figure 9-8: Output Frequency Supervision

2.3.14 Analog input supervision ID356

With this parameter you can select the analog input to be supervised.

- 0** Not used
- 1** AI1
- 2** AI2

2.3.15 Analog input supervision OFF limit ID357

When the signal of analog input selected with par. 2.3.14 falls under the limit set with this parameter, the relay output goes off.

2.3.16 Analog input supervision ON limit ID358

When the signal of analog input selected with par. 2.3.14 goes over the limit set with this parameter, the relay output goes on.

This means that if for example ON limit is 60% and OFF limit is 40%, the relay goes on when signal goes over 60% and remains on until it falls under 40%.

2.3.17 Relay output 1 ON delay ID487**2.3.18 Relay output 1 OFF delay** ID488

With these parameters you can set on- and off-delays to relay output 1 (par 2.3.1).

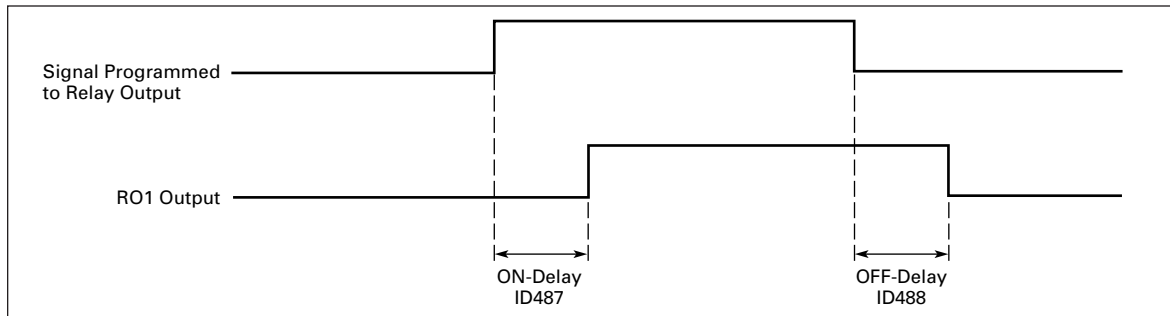

Figure 9-9: Relay Output 1 ON- and OFF-Delays

Drive Control

2.4.1 Acceleration/Deceleration ramp 1 shape ID500

The start and end of the acceleration and deceleration ramps can be smoothed with this parameter. Setting value 0 gives a linear ramp shape which causes acceleration and deceleration to act immediately to the changes in the reference signal.

Setting value 0.1 – 10 seconds for this parameter produces an S-shaped acceleration/ deceleration. The acceleration time is determined with parameters 2.1.3/2.1.4.

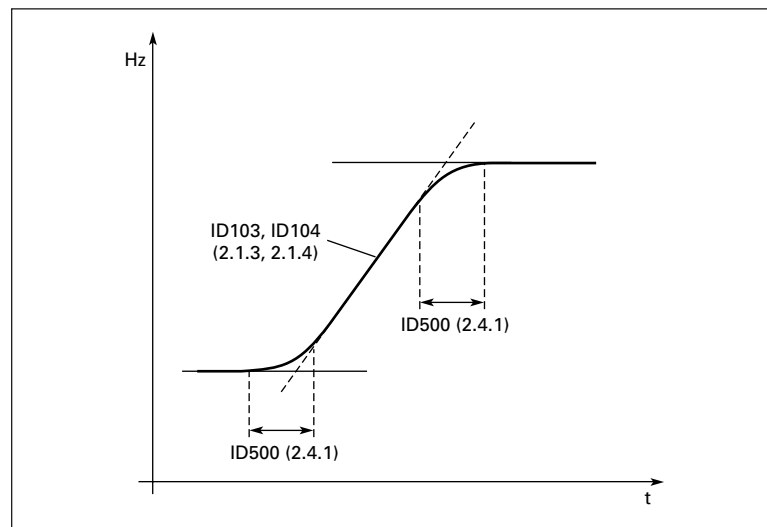

Figure 9-10: Acceleration/Deceleration (S-Shaped)

October 2007

2.4.2 Brake chopper ID504

Note: An internal brake chopper is installed.

- 0** No brake chopper used
- 1** Brake chopper used in Run state
- 3** Used in Run and Stop state

When the drive is decelerating the motor, the inertia of the motor and the load are fed into an external brake resistor. This enables the drive to decelerate the load with a torque equal to that of acceleration (provided that the correct brake resistor has been selected). See separate Brake resistor installation manual.

2.4.3 DC-braking current ID507

Defines the current injected into the motor during DC-braking.

2.4.4 DC-braking time at stop ID508

Determines if braking is ON or OFF and the braking time of the DC-brake when the motor is stopping. The function of the DC-brake depends on the stop function, parameter 2.1.12.

- 0** DC-brake is not used
- >0** DC-brake is in use and its function depends on the Stop function, (par. 2.1.12). The DC-braking time is determined with this parameter.

Par. 2.1.12 = 0 (Stop function = Coasting):

After the stop command, the motor coasts to a stop without control from the drive.

With the DC injection, the motor can be electrically stopped in the shortest possible time, without using an optional external braking resistor.

The braking time is scaled by the frequency when the DC-braking starts. If the frequency is greater than the nominal frequency of the motor, the set value of parameter 2.4.4 determines the braking time. When the frequency is $\leq 10\%$ of the nominal, the braking time is 10% of the set value of parameter 2.4.4.

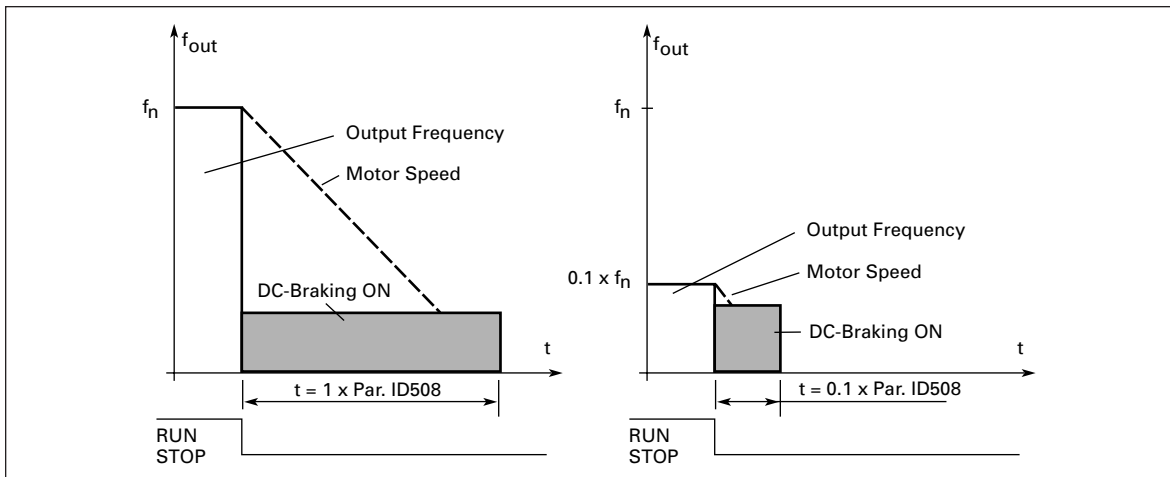

Figure 9-11: DC-Braking Time When Stop Mode = Coasting

Par. 2.1.12 = 1 (Stop function = Ramp):

After the Stop command, the speed of the motor is reduced according to the set deceleration parameters, as fast as possible, to the speed defined with parameter 2.4.5, where the DC-braking starts.

The braking time is defined with parameter 2.4.4. If high inertia exists, it is recommended to use an external braking resistor for faster deceleration. See **Figure 9-12**.

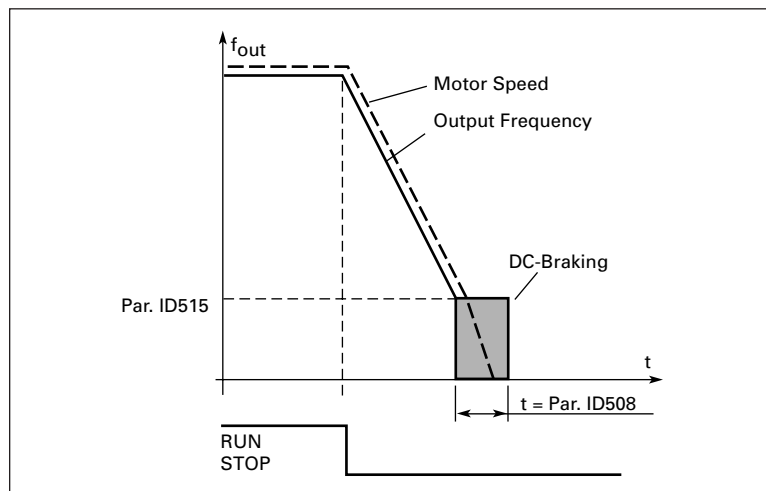

Figure 9-12: DC-Braking Time When Stop Mode = Ramp

2.4.5 DC-braking frequency in ramp stop ID515

The output frequency at which the DC-braking is applied. See **Figure 9-12**.

October 2007

2.4.6 DC-braking time at start ID516

DC-brake is activated when the start command is given. This parameter defines the time before the brake is released. After the brake is released, the output frequency increases according to the set start function by parameter 2.1.11. See **Figure 9-13**.

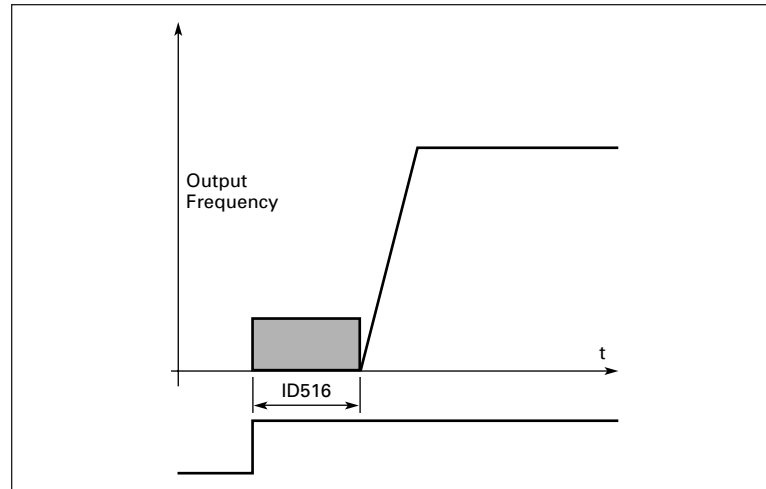
**Figure 9-13: DC Braking Time at Start****2.4.7 Flux brake** ID520

Instead of DC braking, flux braking is a useful form of braking with motors ≤ 15 kW.

When braking is needed, the frequency is reduced and the flux in the motor is increased, which in turn increases the motor's capability to brake. Unlike DC braking, the motor speed remains controlled during braking.

Flux braking can be set ON or OFF.

0 Flux braking OFF

1 Flux braking ON

Note: Flux braking converts the energy into heat at the motor and should be used intermittently to avoid motor damage.

2.4.8 Flux braking current ID519

Defines the flux braking current value. It can be set between $0.3 \times I_H$ (approximately) and the current limit.

Prohibit Frequencies**2.5.1 Prohibit frequency area 1; Low limit** ID509**2.5.2 Prohibit frequency area 1; High limit** ID510

In some systems it may be necessary to avoid certain frequencies because of mechanical resonance problems. With these parameters it is possible to set a limit for the "skip frequency" region. See **Figure 9-14**.

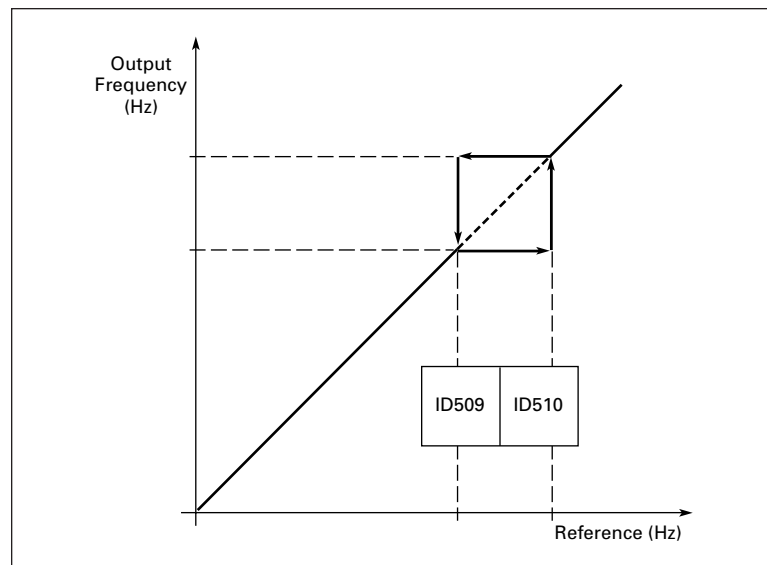

Figure 9-14: Prohibit Frequency Area Setting

2.5.3 Acceleration/deceleration ramp speed scaling ratio between prohibit frequency limits ID518

Defines the acceleration/deceleration time when the output frequency is between the selected prohibit frequency range limits (parameters 2.5.1 and 2.5.2). The ramping time (selected acceleration/ deceleration time 1 or 2) is multiplied with this factor. E.g. value 0.1 makes the acceleration time 10 times shorter than outside the prohibit frequency range limits.

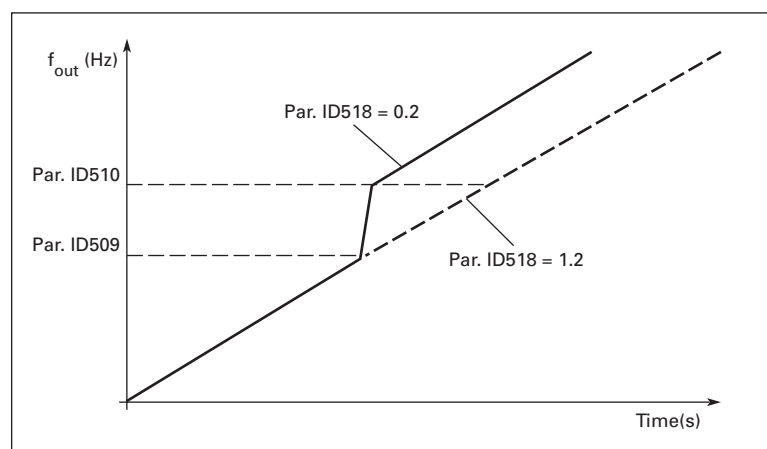

Figure 9-15: Ramp Speed Scaling Between Prohibit Frequencies

October 2007

Motor Control

- 2.6.1 Motor control mode** ID600
- 0** Frequency control: The I/O terminal and keypad references are frequency references and the drive controls the output frequency (output frequency resolution = 0.01 Hz).
 - 1** Speed control: The I/O terminal and keypad references are speed references and the drive controls the motor speed (accuracy $\pm 0.5\%$).

- 2.6.2 VHz ratio selection** ID108
- Linear: 0** The voltage of the motor changes linearly with the frequency in the constant flux area from 0 Hz to the field weakening point where the nominal voltage is supplied to the motor. Linear VHz ratio should be used in constant torque applications. See **Figure 9-16**.

This default setting should be used if there is no special need for another setting.

- Squared: 1** The voltage of the motor changes following a squared curve form with the frequency in the area from 0 Hz to the field weakening point where the nominal voltage is also supplied to the motor. The motor runs under magnetized below the field weakening point and produces less torque and electromechanical noise. Squared VHz ratio can be used in applications where torque demand of the load is proportional to the square of the speed, e.g in centrifugal fans and pumps.

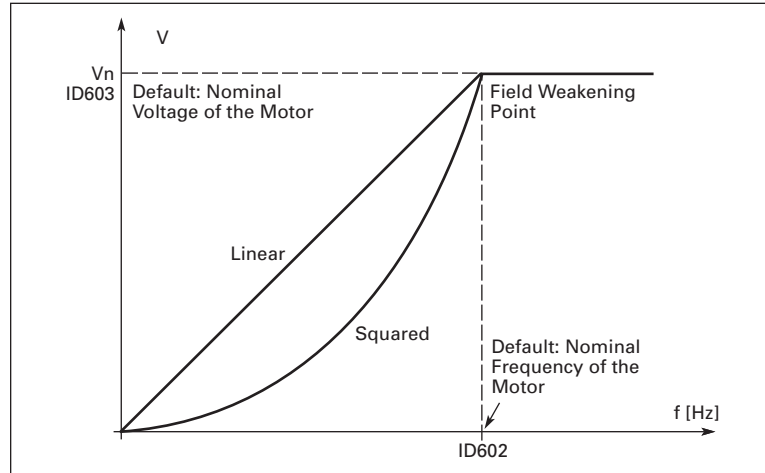

Figure 9-16: Linear and Squared Change of Motor Voltage

- Programmable VHz curve: 2** The VHz curve can be programmed with three different points. Programmable VHz curve can be used if the other settings do not satisfy the needs of the application.
- Linear with flux optimization: 3** The drive starts to search for the minimum motor current and in order to save energy, lower the disturbance level and the noise. Can be used in applications with constant motor load, such as fans, pumps, etc.

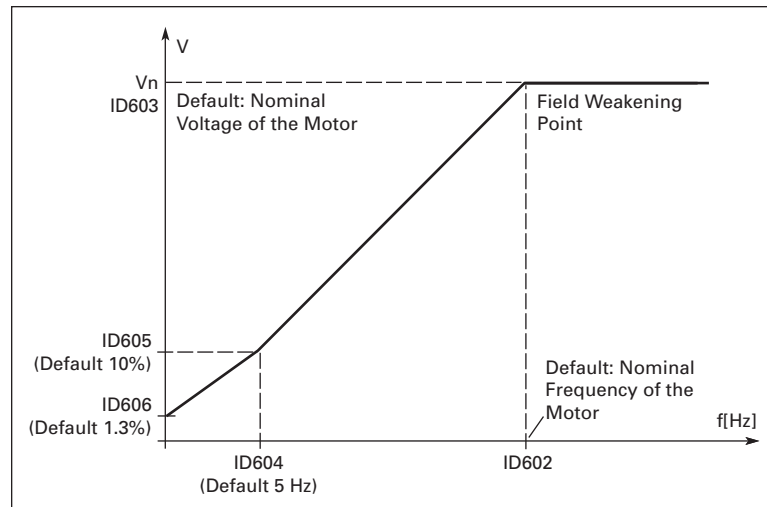

Figure 9-17: Programmable VHz Curve

2.6.3 Field weakening point ID602

The field weakening point is the output frequency at which the output voltage reaches the value set with par. 2.6.4.

2.6.4 Voltage at field weakening point ID603

Above the frequency at the field weakening point, the output voltage remains at the value set with this parameter. Below the frequency at the field weakening point, the output voltage depends on the setting of the VHz curve parameters. See parameters 2.1.13, 2.6.2, 2.6.5, 2.6.6 and 2.6.7 and **Figure 9-17**.

When the parameters 2.1.6 and 2.1.7 (nominal voltage and nominal frequency of the motor) are set, the parameters 2.6.3 and 2.6.4 are automatically given the corresponding values. If you need different values for the field weakening point and the voltage, change these parameters after setting the parameters 2.1.6 and 2.1.7.

2.6.5 VHz curve, middle point frequency ID604

If the programmable VHz curve has been selected with parameter 2.6.2, this parameter defines the middle point frequency of the curve. See **Figure 9-17**.

2.6.6 VHz curve, middle point voltage ID605

If the programmable VHz curve has been selected with the parameter 2.6.2, this parameter defines the middle point voltage of the curve. See **Figure 9-17**.

October 2007

2.6.7 Output voltage at zero frequency ID606

This parameter defines the zero frequency voltage of the curve. See **Figure 9-17**.

2.6.8 Switching frequency ID601

Motor noise can be minimized using a high switching frequency. Increasing the switching frequency reduces the capacity of the drive.

Switching frequency for SLX9000: 1 – 16 kHz

2.6.9 Overvoltage controller ID607**2.6.10 Undervoltage controller** ID608

These parameters allow the under-/overvoltage controllers to be switched out of operation. This may be useful, for example, if the utility supply voltage varies more than -15% to +10% and the application will not tolerate this over-/undervoltage. This regulator controls the output frequency taking the supply fluctuations into account.

Note: Over-/undervoltage trips may occur when controllers are switched out of operation.

0 Controller switched off

1 Controller switched on

2.6.11 Identification ID631

0 No action

1 ID no run

When ID no run is selected, the drive will perform an ID-run when it is started from selected control place. Drive has to be started within 20 seconds, otherwise identification is aborted.

The drive does not rotate the motor during ID no run. When ID run is ready, the drive is stopped. Drive will start normally when the next start command is given.

The ID run improves the torque calculations and the automatic torque boost function. It will also result in a better slip compensation in speed control (more accurate RPM).

Protections

2.7.1 Response to 4 mA reference fault ID700

0 No response

1 Warning

2 Fault, stop mode after fault according to parameter 2.1.12

3 Fault, stop mode after fault always by coasting

A warning or a fault action and message is generated if the 4 – 20 mA reference signal is used and the signal falls below 3.5 mA for 5 seconds or below 0.5 mA for 0.5 seconds. The information can also be programmed into relay outputs.

2.7.2 Response to external fault ID701

- 0 No response
- 1 Warning
- 2 Fault, stop mode after fault according to parameter 2.1.12
- 3 Fault, stop mode after fault always by coasting

A warning or a fault action and message is generated from the external fault signal in the programmable digital inputs. The information can also be programmed into relay outputs.

2.7.3 Response to undervoltage fault ID727

- 1 Warning
- 2 Fault, stop mode after fault according to parameter 2.1.12
- 3 Fault, stop mode after fault always by coasting

For the undervoltage limits see **Table 1-8**.

Note: This protection can not be inactivated.

2.7.4 Output phase supervision ID702

- 0 No response
- 1 Warning
- 2 Fault, stop mode after fault according to parameter 2.1.12
- 3 Fault, stop mode after fault always by coasting

Output phase supervision of the motor ensures that the motor phases have an approximately equal currents.

2.7.5 Ground fault protection ID703

- 0 No response
- 1 Warning
- 2 Fault, stop mode after fault according to parameter 2.1.12
- 3 Fault, stop mode after fault always by coasting

Ground fault protection ensures that the sum of the motor phase currents is zero. The overcurrent protection is always working and protects the drive from ground faults with high currents.

October 2007

Motor Thermal Protection:

The motor thermal protection is to protect the motor from overheating. The drive is capable of supplying higher than nominal current to the motor. If the load requires this high current, there is a risk that the motor will be thermally overloaded. This is the case especially at low frequencies. At low frequencies the cooling effect of the motor is reduced as well as its capacity. If the motor is equipped with an external fan, the load reduction at low speeds is small.

The motor thermal protection is based on a calculated model and it uses the output current of the drive to determine the load on the motor.

The motor thermal protection can be adjusted with parameters. The thermal current I_T specifies the load current above which the motor is overloaded. This current limit is a function of the output frequency.

 **CAUTION**

The calculated model does not protect the motor if the airflow to the motor is reduced by blocked air intake grill.

2.7.6 Motor thermal protection ID704

- | | |
|----------|--|
| 0 | No Response |
| 1 | Warning |
| 2 | Fault, stop mode after fault according to parameter 2.1.12 |
| 3 | Fault, stop mode after fault always by coasting |

If tripping is selected, the drive will stop and activate the fault stage.

Deactivating the protection, i.e. setting parameter to 0, will reset the thermal model of the motor to 0%.

2.7.7 Motor thermal protection: Motor ambient temperature factor ID705

When the motor ambient temperature must be taken into consideration, it is recommended to set a value for this parameter. The value of the factor can be set between -100.0% and 100.0% where -100.0% corresponds to 0°C and 100.0% to the maximum running ambient temperature of the motor. Setting this parameter value to 0% assumes that the ambient temperature is the same as the temperature of the heatsink at power-on.

2.7.8 Motor thermal protection: Cooling factor at zero speed ID706

The cooling power can be set between 0 – 150.0% x cooling power at nominal frequency. See **Figure 9-18**.

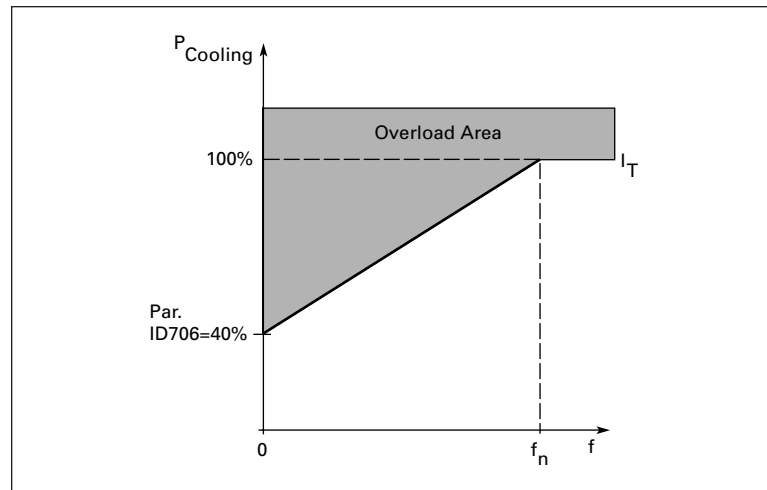

Figure 9-18: Motor Cooling Power

2.7.9 Motor thermal protection: Time constant ID707

This time can be set between 1 and 200 minutes.

This is the thermal time constant of the motor. The bigger the motor, the bigger the time constant. The time constant is the time within which the calculated thermal model has reached 63% of its final value.

The motor thermal time is specific to the motor design and it varies between different motor manufacturers.

If the motor's t_6 -time (t_6 is the time in seconds the motor can safely operate at six times the rated current) is known (given by the motor manufacturer) the time constant parameter can be set basing on it. As a rule of thumb, the motor thermal time constant in minutes equals to $2 \times t_6$. If the drive is in stop state, the time constant is internally increased to three times the set parameter value. The cooling in the stop state is based on convection and the time constant is increased. See also **Figure 9-19**.

Note: If the nominal speed (par. 2.1.8) or the nominal current (par. 2.1.9) of the motor are changed, this parameter is automatically set to the default value (45).

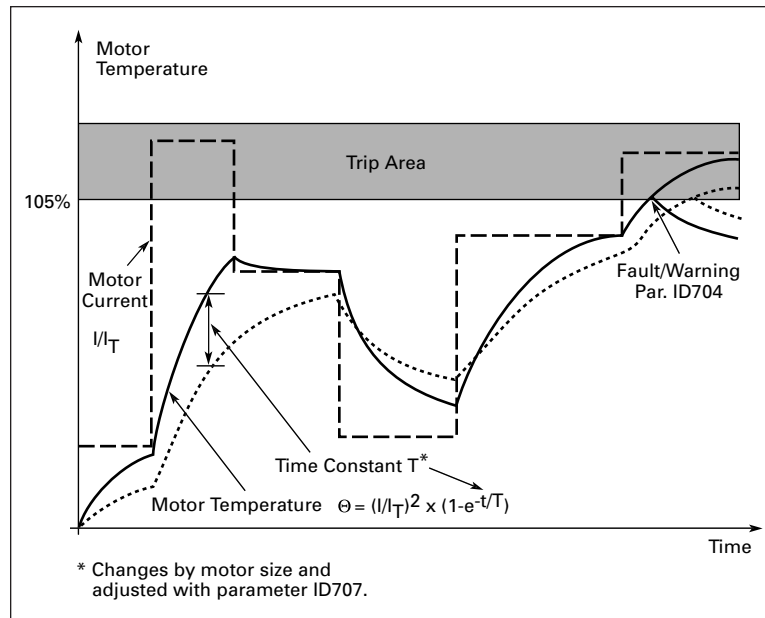

Figure 9-19: Motor Temperature Calculation

2.7.10 Motor thermal protection: Motor duty cycle ID708

Defines how much of the nominal motor load is applied.

The value can be set to 0% – 100%.

Stall Protection

The motor stall protection protects the motor from short time overload situations such as one caused by a stalled shaft. The reaction time of the stall protection can be set shorter than that of motor thermal protection. The stall state is defined with two parameters, 2.7.12 (Stall current) and 2.7.13 (Stall frequency). If the current is higher than the set limit and output frequency is lower than the set limit, the stall state is true. There is actually no real indication of the shaft rotation. Stall protection is a type of overcurrent protection.

2.7.11 Stall protection ID709

- 0** No response
- 1** Warning
- 2** Fault, stop mode after fault according to parameter 2.1.12
- 3** Fault, stop mode after fault always by coasting

Setting the parameter to 0 will deactivate the protection and reset the stall time counter.

2.7.12 Stall current limit

ID710

The current can be set to $0.0 - I_{nMotor} * 2$. For a stall stage to occur, the current must have exceeded this limit. See **Figure 9-20**. The software does not allow entering a greater value than $I_{nMotor} * 2$. If the parameter 2.1.9 Nominal current of motor is changed, this parameter is automatically restored to the default value ($I_{nMotor} * 1.3$).

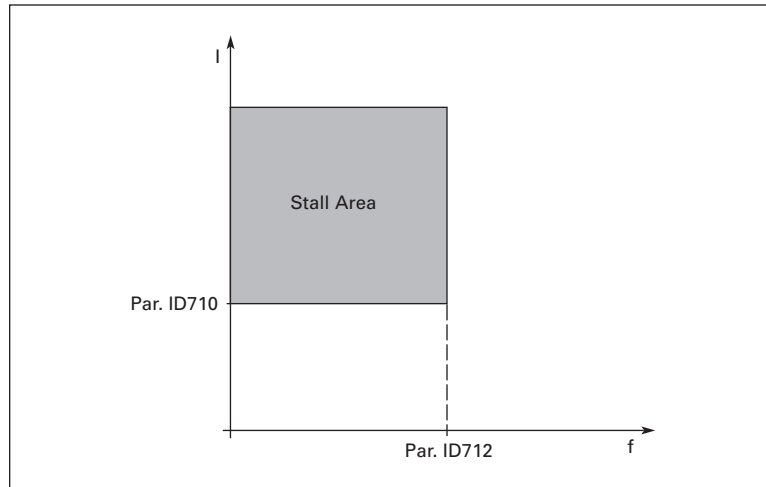

Figure 9-20: Stall Characteristics Settings

2.7.13 Stall time

ID711

This time can be set between 1.0 and 120.0s.

This is the maximum time allowed for a stall event detection. The stall time is counted by an internal up/down counter.

If the stall time counter value goes above this limit, the protection will cause a trip (see **Figure 9-21**).

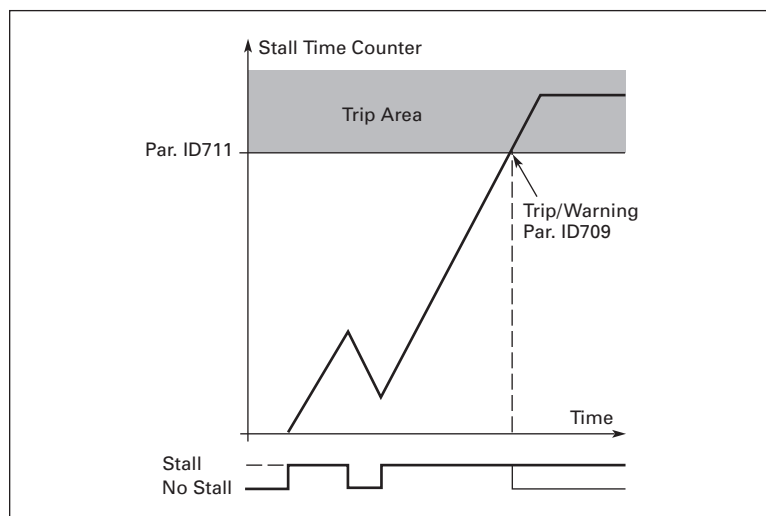

Figure 9-21: Stall Time Count

October 2007

2.7.14 Maximum stall frequency ID712

The frequency can be set between 1-fmax (par. 2.1.2).

For a stall event to occur, the output frequency must have remained below this limit.

Underload Protection

The purpose of the motor underload protection is to ensure that there is load on the motor when the drive is running. If the motor loses its load, there might be a problem in the process, e.g. a broken belt or a dry pump.

Motor underload protection can be adjusted by setting the underload curve with parameters 2.7.16 (Field weakening area load) and 2.7.17 (Zero frequency load), see below. The underload curve is a squared curve set between the zero frequency and the field weakening point. The protection is not active below 5 Hz (the underload time counter is stopped).

The torque values for setting the underload curve are set in percentage of nominal torque of the motor. The motor's nameplate data, the parameter Motor nominal current and the drive's nominal current I_L are used to find the scaling ratio for the internal torque value. If other than nominal motor is used with the drive, the accuracy of the torque calculation decreases.

2.7.15 Underload protection ID713

- | | |
|---|--|
| 0 | No response |
| 1 | Warning |
| 2 | Fault, stop mode after fault according to parameter 2.1.12 |
| 3 | Fault, stop mode after fault always by coasting |

If tripping is set active, the drive will stop and activate the fault stage.

Deactivating the protection by setting the parameter to 0 will reset the underload time counter.

2.7.16 Underload protection, field weakening area load ID714

The torque limit can be set between 10.0 and $150.0\% \times T_{nMotor}$.

This parameter gives the value for the minimum torque allowed when the output frequency is above the field weakening point. See **Figure 9-22**.

If you change the parameter 2.1.9 (Motor nominal current), this parameter is automatically restored to the default value.

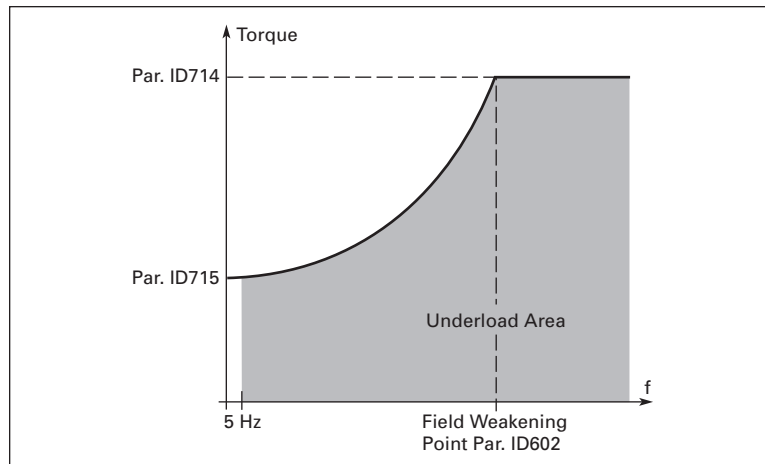

Figure 9-22: Setting of Minimum Load

2.7.17 Underload protection, zero frequency load ID715

The torque limit can be set between 5.0 and 150.0% $\times T_{nMotor}$.

This parameter gives value for the minimum torque allowed with zero frequency. See **Figure 9-22**.

If you change the value of parameter 2.1.9 (Motor nominal current), this parameter is automatically restored to the default value.

2.7.18 Underload time ID716

This time can be set between 2.0 and 600.0 s.

This is the maximum time allowed for an underload state to exist. An internal up/down counter counts the accumulated underload time. If the underload counter value goes above this limit the protection will cause a trip according to parameter 2.7.15). If the drive is stopped, the underload counter is reset to zero. See **Figure 9-23**.

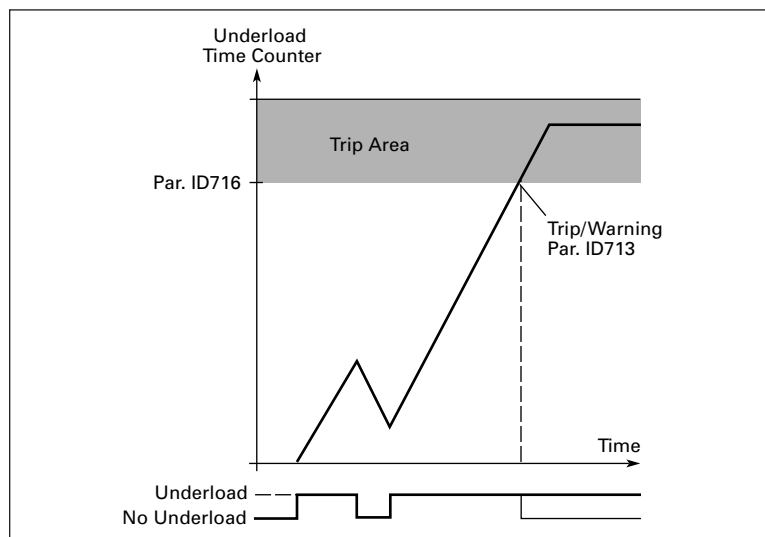

Figure 9-23: Underload Time Counter Function

October 2007

2.7.19 Response to thermistor fault ID732

- 0 No response
- 1 Warning
- 2 Fault, stop mode after fault according to parameter 2.1.12
- 3 Fault, stop mode after fault always by coasting

Setting the parameter to 0 will deactivate the protection.

2.7.20 Response to fieldbus fault ID733

Sets the response mode for the fieldbus fault if a fieldbus board is used. For more information, see the respective Fieldbus Board Manual.

See parameter 2.7.19.

2.7.21 Response to slot fault ID734

Sets the response mode for a board slot fault due to missing or broken board.

See parameter 2.7.19.

2.7.22 Actual value supervision function ID735

- 0 Not used
- 1 Warning, if actual value falls below the limit set with par. 2.7.23
- 2 Warning, if actual value exceeds the limit set with par. 2.7.23
- 3 Fault, if actual value falls below the limit set with par. 2.7.23
- 4 Fault, if actual value exceeds the limit set with par. 2.7.23

2.7.23 Actual value supervision limit ID736

With this parameter you can set the limit of actual value supervised by par. 2.7.22.

2.7.24 Actual value supervision delay ID737

Sets the delay for the actual value supervision function (par. 2.7.22).

If this parameter is in use, the function of par. 2.7.22 will be active only when the actual value stays outside the defined limit for the time determined by this parameter.

Auto Restart Parameters

The automatic restart function is active if the value of par. 2.1.21 = 1. There are always three restart trials.

2.8.1 Automatic restart: Wait time ID717

Defines the time before the drive tries to automatically restart the motor after the fault has disappeared.

2.8.2 Automatic restart: Trial time ID718

The Automatic restart function restarts the drive when the faults have disappeared and the waiting time has elapsed.

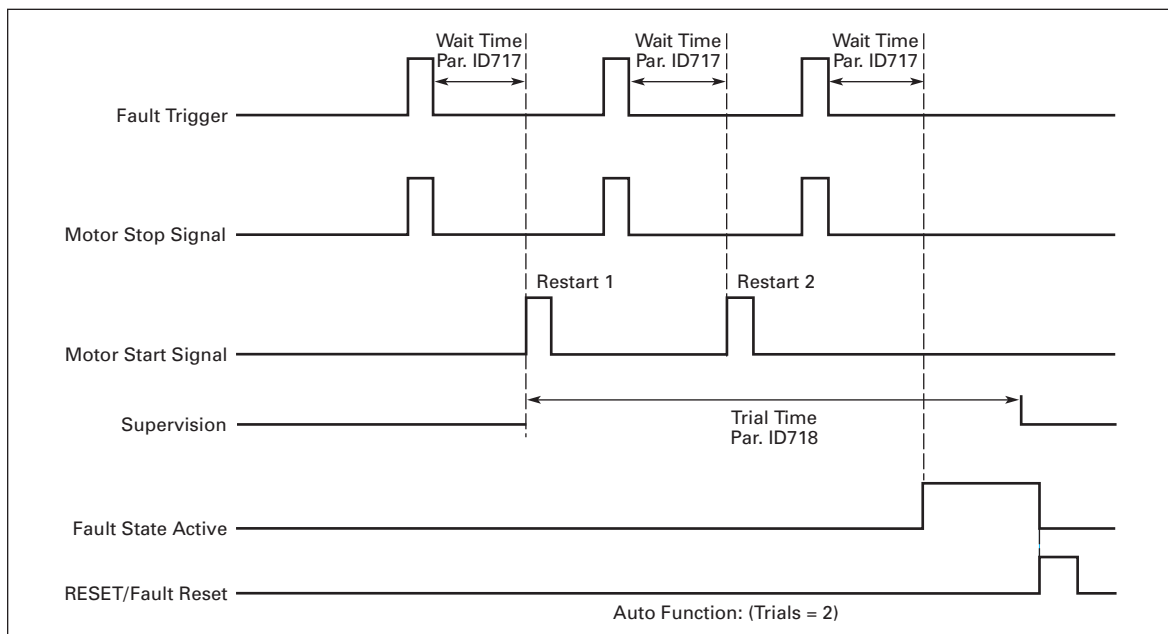

Figure 9-24: Automatic Restart

The time count starts from the first autorestart. If the number of faults occurring during the trial time exceeds three, the fault state becomes active. Otherwise the fault is cleared after the trial time has elapsed and the next fault starts the trial time count again.

If a single fault remains during the trial time, a fault state is true.

2.8.3 Automatic restart, start function ID719

The Start function for Automatic restart is selected with this parameter. The parameter defines the start mode:

- 0** Start with ramp
- 1** Flying start
- 2** Start according to par. 2.1.11

October 2007

PID Reference Parameters

2.9.1 PID activation ID163

With this parameter you can activate or deactivate the PID controller or activate the pump and fan control parameters.

- 0** PID controller deactivated
- 1** PID controller activated
- 2** Pump and fan control activated. Parameter group P2.10 becomes visible.

2.9.2 PID reference ID332

Defines which frequency reference source is selected for the PID controller. Default value is 2.

- 0** AI1 reference
- 1** AI2 reference
- 2** PID reference from the Keypad control page (Group K3, parameter R3.5)
- 3** Reference from the fieldbus (FBProcessDataIN1)

2.9.3 Actual value input ID334

- 0** AI1
- 1** AI2
- 2** Fieldbus (Actual value 1: FBProcessDataIN2; Actual value 2: FBProcessDataIN3)
- 3** Motor torque
- 4** Motor speed
- 5** Motor current
- 6** Motor power

2.9.4 PID controller gain ID118

This parameter defines the gain of the PID controller. If the value of the parameter is set to 100% a change of 10% in the error value causes the controller output to change by 10%.

If the parameter value is set to 0 the PID controller operates as ID-controller.

See examples below.

2.9.5 PID controller I-time ID119

This parameter defines the integration time of the PID controller. If this parameter is set to 1.00 second, a change of 10% in the error value causes the controller output to change by 10.00%/s. If the parameter value is set to 0.00 s, the PID controller will operate as PD-controller. See examples below.

2.9.6 PID controller D-time ID132

The parameter 2.9.5 defines the derivative time of the PID controller. If this parameter is set to 1.00 second, a change of 10% in the error value during 1.00 s causes the controller output to change by 10.00%. If the parameter value is set to 0.00 s, the PID controller will operate as PI-controller.

See examples below.

Example 1:

In order to reduce the error value to zero, with the given values, the drive output behaves as follows:

Given values:

- | | |
|---|------------------------|
| Par. 2.9.4, P = 0% | PID max limit = 100.0% |
| Par. 2.9.5, I-time = 1.00 s | PID min limit = 0.0% |
| Par. 2.9.6, D-time = 0.00 s | Min freq. = 0 Hz |
| Error value (setpoint - process value) = 10.00% | Max freq. = 50 Hz |

In this example, the PID controller operates practically as I-controller only.

According to the given value of parameter 2.9.5 (I-time), the PID output increases by 5 Hz (10% of the difference between the maximum and minimum frequency) every second until the error value is 0.

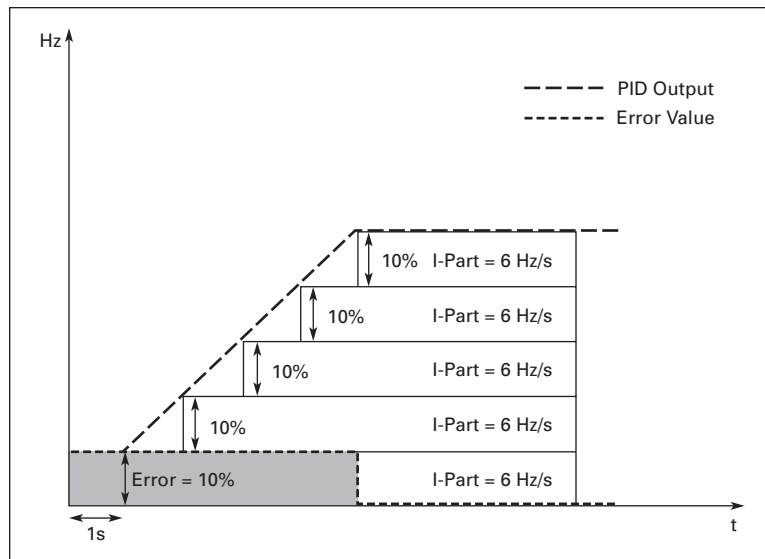

Figure 9-25: PID Controller Function as I-Controller

October 2007

Example 2:

Given values:

Par. 2.9.4, P = 100%

PID max limit = 100.0%

Par. 2.9.5, I-time = 1.00 s

PID min limit = 0.0%

Par. 2.9.6, D-time = 1.00 s

Min freq. = 0 Hz

Error value (setpoint - process value) = ±10%

Max freq. = 50 Hz

As the power is switched on, the system detects the difference between the setpoint and the actual process value and starts to either raise or decrease (in case the error value is negative) the PID output according to the I-time. Once the difference between the setpoint and the process value has been reduced to 0, the output is reduced by the amount corresponding to the value of parameter 2.9.5.

In case the error value is negative, the drive reacts, reducing the output correspondingly.

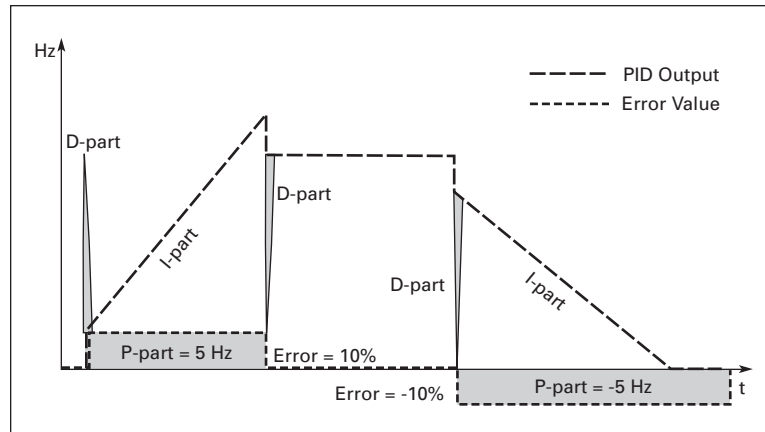

Figure 9-26: PID Output Curve with the Values of Example 2

Example 3:

Given values:

Par. 2.9.4, P = 100%

PID max limit = 100.0%

Par. 2.9.5, I-time = 0.00 s

PID min limit = 0.0%

Par. 2.9.6, D-time = 1.00 s

Min freq. = 0 Hz

Error value (setpoint - process value) =
 $\pm 10\%/s$

Max freq. = 50 Hz

As the error value increases, the PID output also increases according to the set values (D-time = 1.00s).

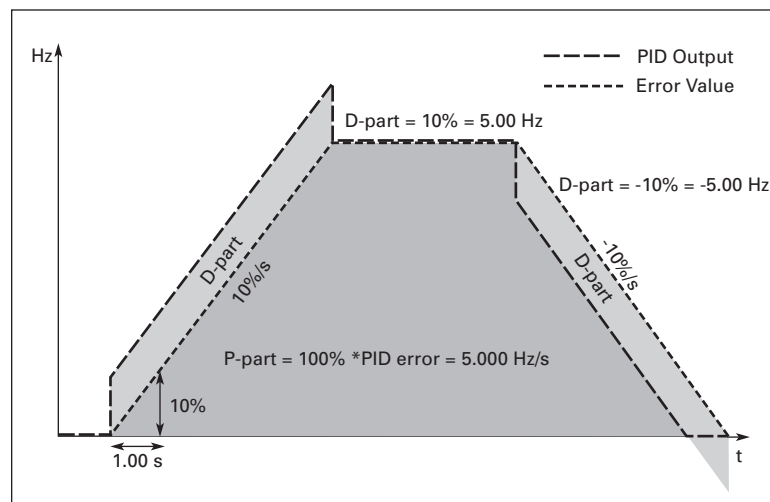
**Figure 9-27: PID Output with the Values of Example 3****2.9.7 Actual value 1 minimum scale**

ID336

Sets the minimum scaling point for Actual value 1. See **Figure 9-28**.**2.9.8 Actual value 1 maximum scale**

ID337

Sets the maximum scaling point for Actual value 1. See **Figure 9-28**.

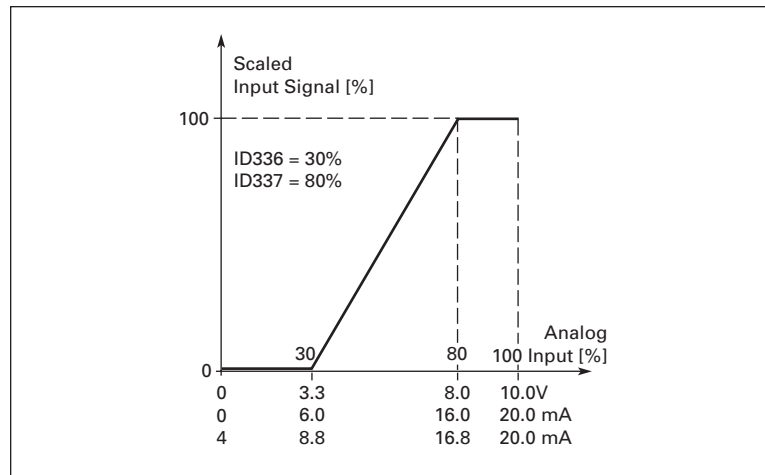

Figure 9-28: Example of Actual Value Signal Scaling

2.9.9 PID error value inversion ID340

This parameter allows you to invert the error value of the PID controller (and thus the operation of the PID controller).

- 0** No inversion
- 1** Inverted

2.9.10 Sleep frequency ID1016

The drive is stopped automatically if the frequency of the drive falls below the Sleep level defined with this parameter for a time greater than that determined by parameter 2.9.11. During the Stop state, the PID controller is operating switching the drive to Run state when the actual value signal either falls below or exceeds (see par. 2.9.13) the Wake-up level determined by parameter 2.9.12. See **Figure 9-29**.

2.9.11 Sleep delay ID1017

The minimum amount of time the frequency has to remain below the Sleep level before the drive is stopped. See **Figure 9-29**.

2.9.12 Wake-up level ID1018

The wake-up level defines the frequency below which the actual value must fall or which has to be exceeded before the Run state of the drive is restored. See **Figure 9-29**.

2.9.13 Wake-up function ID1019

This parameter defines if the restoration of the Run state occurs when the actual value signal falls below or exceeds the Wake-up level (par. 2.9.12). See **Figure 9-29**.

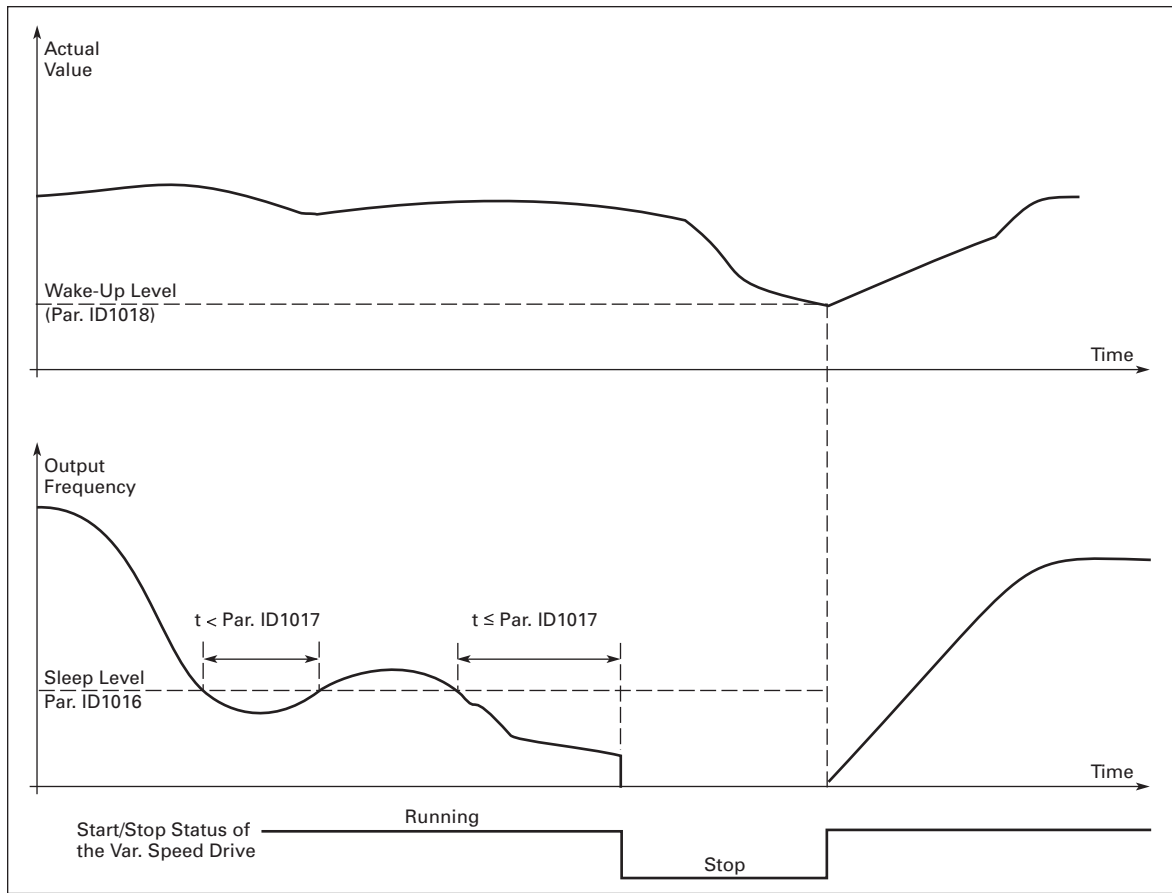

Figure 9-29: Sleep Function

October 2007

Table 9-3: Selectable Wake-Up Functions

Parameter Value	Function	Limit	Description
0	Wake-up happens when actual value goes below the limit	The limit defined with parameter ID1018 is in percent of the maximum actual value	
1	Wake-up happens when actual value exceeds the limit	The limit defined with parameter ID1018 is in percent of the maximum actual value	
2	Wake-up happens when actual value goes below the limit	The limit defined with parameter ID1018 is in percent of the current value of the reference signal	
3	Wake-up happens when actual value exceeds the limit	The limit defined with parameter ID1018 is in percent of the current value of the reference signal	

Pump and Fan Control

The Pump and Fan Control can be used to control one variable speed drive and up to three auxiliary drives. The PID controller of the drive controls the speed of the variable speed drive and gives control signals to start and stop the auxiliary drives to control the total flow. In addition to the eight parameter groups provided as standard, a parameter group for multi-pump and fan control functions is available.

Pump and Fan Control is used to control the operation of pumps and fans. The application utilizes external contactors for switching between the motors connected to the drive. The autochange feature provides the capability of changing the starting order of the auxiliary drives.

Short Description of PFC Function and Essential Parameters

Automatic Changing Between Drives (Autochange & Interlockings Selection, P2.10.4/ID1027)

The automatic change of starting and stopping order is activated and applied to either the auxiliary drives only or the auxiliary drives and the drive controlled by the frequency converter depending on the setting of parameter 2.10.4.

The Autochange function allows the starting and stopping order of drives controlled by the pump and fan automatics to be changed at desired intervals. The drive controlled by frequency converter can also be included in the automatic changing and locking sequence (par 2.10.4). The Autochange function makes it possible to equalize the run times of the motors and to prevent, for example, pump stalls due to running breaks that are too long.

- Apply the Autochange function with parameter 2.10.4, Autochange.
- The autochange takes place when the time set with parameter 2.10.5 Autochange interval has expired and the capacity used is below the level defined with parameter 2.10.7, Autochange frequency limit.
- The running drives are stopped and re-started according to the new order.
- External contactors controlled through the relay outputs of the frequency converter connect the drives to the frequency converter or to the mains. If the motor controlled by the frequency converter is included in the autochange sequence, it is always controlled through the relay output activated first. The other relays activated later control the auxiliary drives.

This parameter is used to activate the interlock inputs (Values 3 & 4). The interlocking signals come from the motor switches. The signals (functions) are connected to digital inputs which are programmed as interlock inputs using the corresponding parameters. The pump and fan control automatics only control the motors with active interlock data.

- If the interlock of an auxiliary drive is inactivated and another unused auxiliary drive available, the latter will be put to use without stopping the frequency converter.
- If the interlock of the controlled drive is inactivated, all motors will be stopped and re-started with the new set-up.
- If the interlock is re-activated in Run status, the automatics will stop all motors immediately and re-start with a new setup. Example: [P1 → P3] → [P2 LOCKED] → [STOP] → [P1 → P2 → P3]

See **Page 9-41**, Examples.

October 2007

Parameter 2.10.5/ID1029, Autochange interval

After expiration of the time defined with this parameter, the autochange function takes place if the capacity used lies below the level defined with parameters 2.10.7 (Autochange frequency limit) and 2.10.6 (Maximum number of auxiliary drives). Should the capacity exceed the value of par 2.10.7, the autochange will not take place before the capacity goes below this limit.

- The time count is activated only if the Start/Stop request is active.
- The time count is reset after the autochange has taken place or on removal of Start request

Parameters 2.10.6/ID1030, Maximum number of auxiliary drives and 2.10.7/ID1031, Autochange frequency limit

These parameters define the level below which the capacity used must remain so that the autochange can take place.

This level is defined as follows:

- If the number of running auxiliary drives is smaller than the value of parameter 2.10.6, the autochange function can take place.
- If the number of running auxiliary drives is equal to the value of parameter 2.10.6 and the frequency of the controlled drive is below the value of parameter 2.10.7, the autochange can take place.
- If the value of parameter 2.10.7 is 0.0 Hz, the autochange can take place only in rest position (Stop and Sleep), regardless of the value of parameter 2.10.6.

*Examples***PFC with interlocks and autochange between 3 pumps (OPT-AA or OPT-B5 option board required)**

Situation: 1 controlled drive and 2 auxiliary drives.

Parameter settings: 2.10.1 = 2

Interlock feedback signals used, autochange between all drives used.

Parameter settings: 2.10.4 = 4

DIN4 active (par. 2.2.6 = 0)

The interlock feedback signals come from the digital inputs DIN4 (AI1), DIN2 & DIN3 selected with parameters 2.1.17, 2.1.18 and 2.2.4.

The control of pump 1 (par. 2.3.1 = 17) is enabled through Interlock 1 (DIN2, 2.1.17 = 10), the control of pump 2 (par. 2.3.2 = 18) through Interlock 2 (DIN3, par. 2.1.18 = 13) and the control of pump 3 (par. 2.3.3 = 19) through Interlock 3 (DIN4).

Table 9-4: PFC-Control Input/Output Configuration with Three Pumps, MF4 – MF6 460V

	Terminal	Signal
Reference potentiometer	1	+10V _{ref} Reference output
2-Wire Transmitter	2	AI1+ Voltage input frequency reference/DIN4
	3	AI1- I/O Ground
Actual Value (0)4 – 20mA	4	AI2+ PID Actual Value
	5	AI2-
	6	+24V Control voltage output
	7	GND I/O ground
	8	DIN1 Start
	9	DIN2 Interlock 1 (par 2.1.17 = 10)
	10	DIN3 Interlock 2 (par 2.1.18 = 13)
	11	GND I/O ground
mA	18	AO1+ Output frequency
	19	AO1- Analog output
	A	RS 485 Serial bus
	B	RS 485 Serial bus
	21	RO1 Relay output 1
	22	RO1 FAULT
	23	RO1
OPT-B5		
	22	RO1/1 Autochange 1 (Pump 1 Control), par 2.3.2 = 17
	23	RO1/2
	25	RO2/1 Autochange 2 (Pump 2 Control), par 2.3.3 = 18
	26	RO2/2
	28	RO3/1 Autochange 3 (Pump 3 Control), par 2.3.4 = 19
	29	RO3/2

October 2007

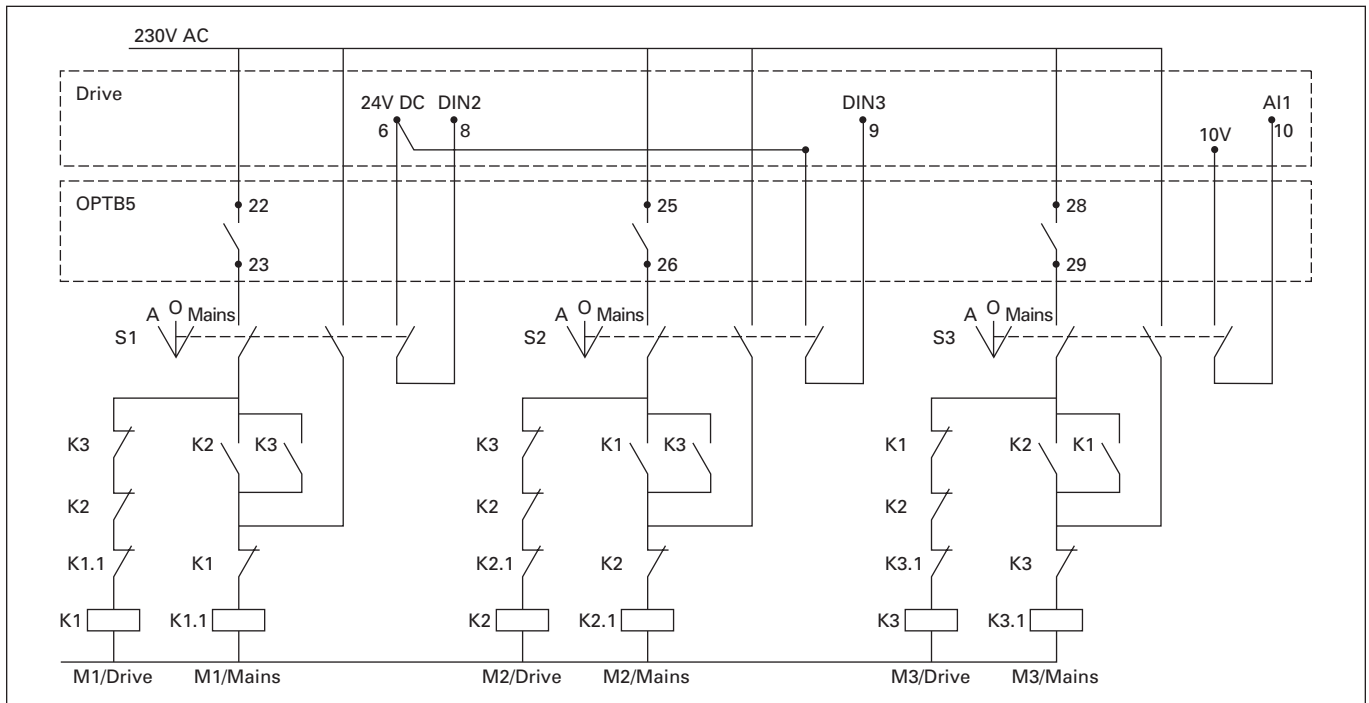

Figure 9-30: 3-Pump Autochange System, Principal Control Diagram

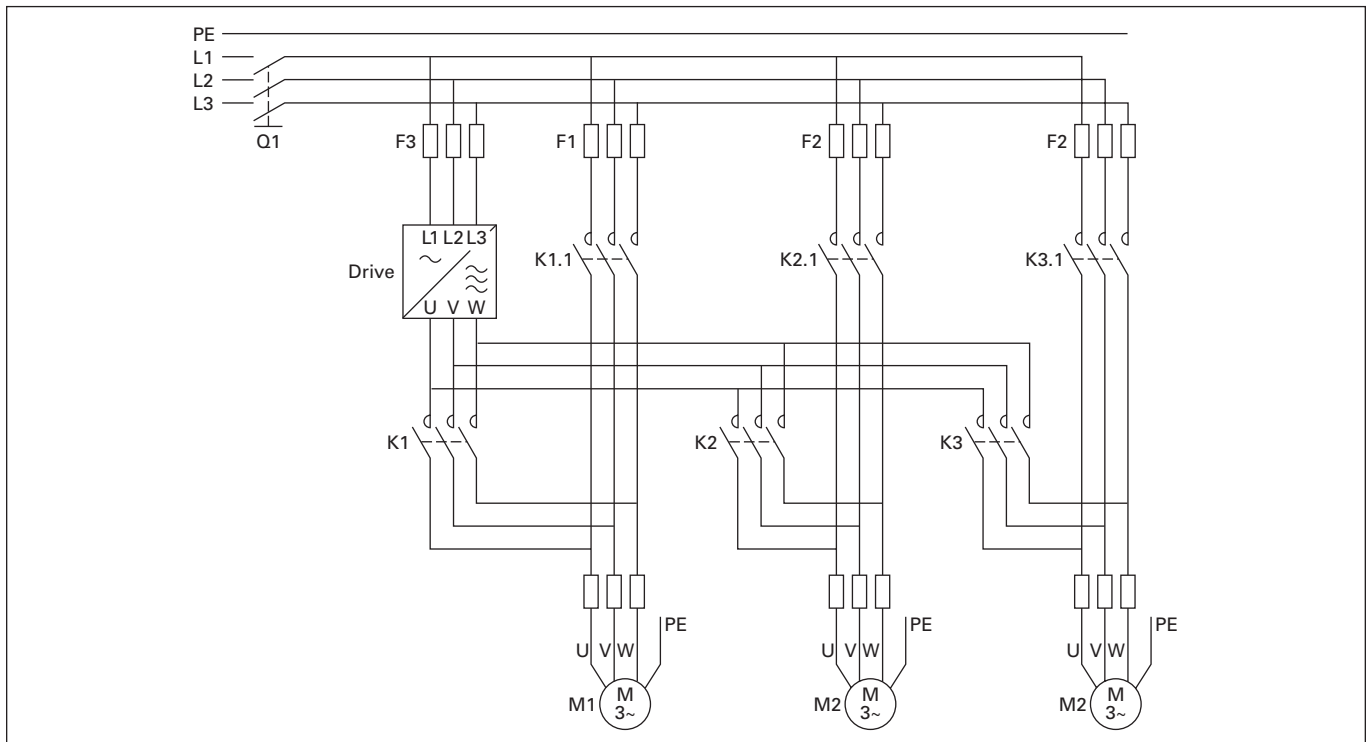

Figure 9-31: Example of 3-Pump Autochange, Main Diagram

PFC with interlocks and autochange between 2 pumps (OPTAA or OPTB5 option board required)

Situation: 1 controlled drive and 1 auxiliary drive.

Parameter settings: 2.10.1 = 1

Interlock feedback signals used, autochange between pumps used.

Parameter settings: 2.10.4 = 4

The interlock feedback signals come from the digital input DIN2 (par. 2.1.17) and digital input DIN3, (par. 2.1.18).

The control of pump 1 (par. 2.3.1 = 17) is enabled through Interlock 1 (DIN2, P2.1.17), the control of pump 2 (par. 2.3.2 = 18) through Interlock 2 (par. 2.1.18 = 13)

Table 9-5: PFC-Control Input/Output Configuration with Two Pumps, MF4 – MF6 460V

	Terminal	Signal
Reference potentiometer	1	+10V _{ref} Reference output
2-Wire Transmitter	2	AI1+ Voltage input frequency reference/DIN4
	3	AI1- I/O Ground
Actual Value (0)4 – 20mA	4	AI2+ PID Actual Value
	5	AI2-
+24V	6	+24V Control voltage output
	7	GND I/O ground
DIN1	8	DIN1 Start
	9	DIN2 Interlock 1 (par 2.1.17 = 10)
DIN3	10	DIN3 Interlock 2 (par 2.1.18 = 13)
	11	GND I/O ground
mA	18	AO1+ Output frequency
	19	AO1- Analog output
RS 485	A	RS 485 Serial bus
	B	RS 485 Serial bus
RO1	21	Autochange 1 (Pump 1 control) par 2.3.1. = 17
	22	
	23	
OPT-AA		
X1		
+24V	1	+24V Control voltage output max. 150 mA
	2	GND Ground for controls, e.g for +24V and DO
DIN1	3	DIN1 Preset speed 2, par 2.2.1 = 7
	4	DIN2 Fault reset, par 2.2.2 = 4
DIN3	5	DIN3 Disable PID (Freq reference from AI1), par 2.2.3 = 11
	6	DO1 Ready, par 2.3.4 = 1 Open collector output, 50 mA/48V
X2		
RO1/NO	22	Autochange 2 (Pump 2 control), par 2.3.2 = 18
	23	

October 2007

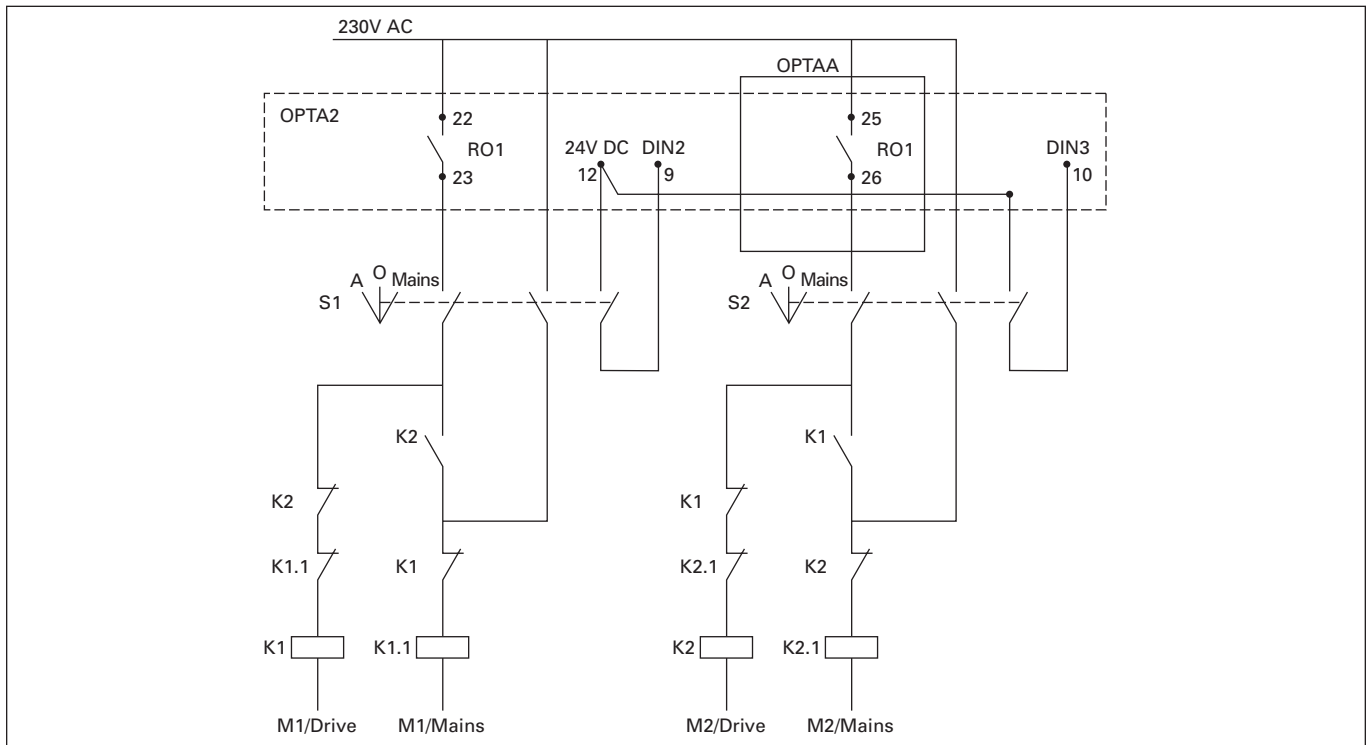

Figure 9-32: 2-Pump Autochange System, Principal Control Diagram

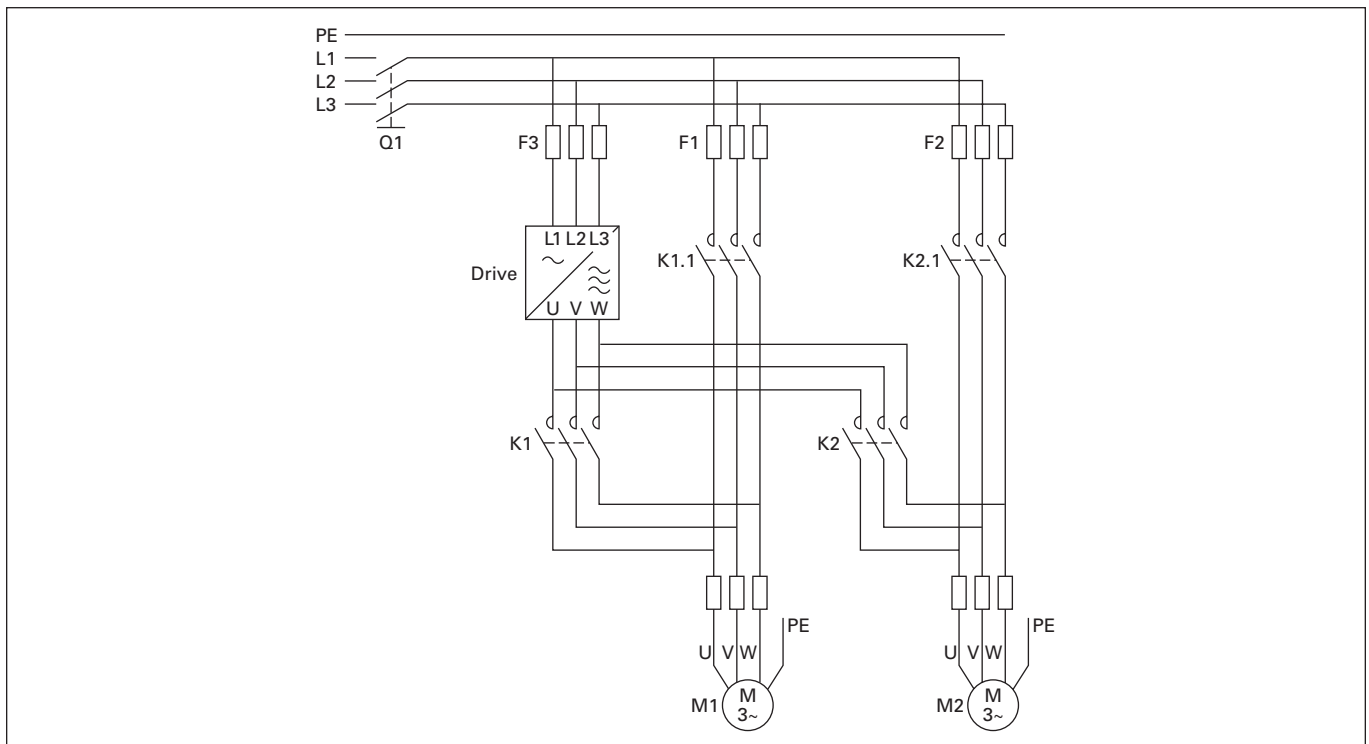

Figure 9-33: Example of 2-Pump Autochange, Main Diagram

2 Autochange with drive and auxiliary pumps

The drive controlled by the drive is included in the automatics and a contactor is needed for each drive to connect it to either the mains or the drive.

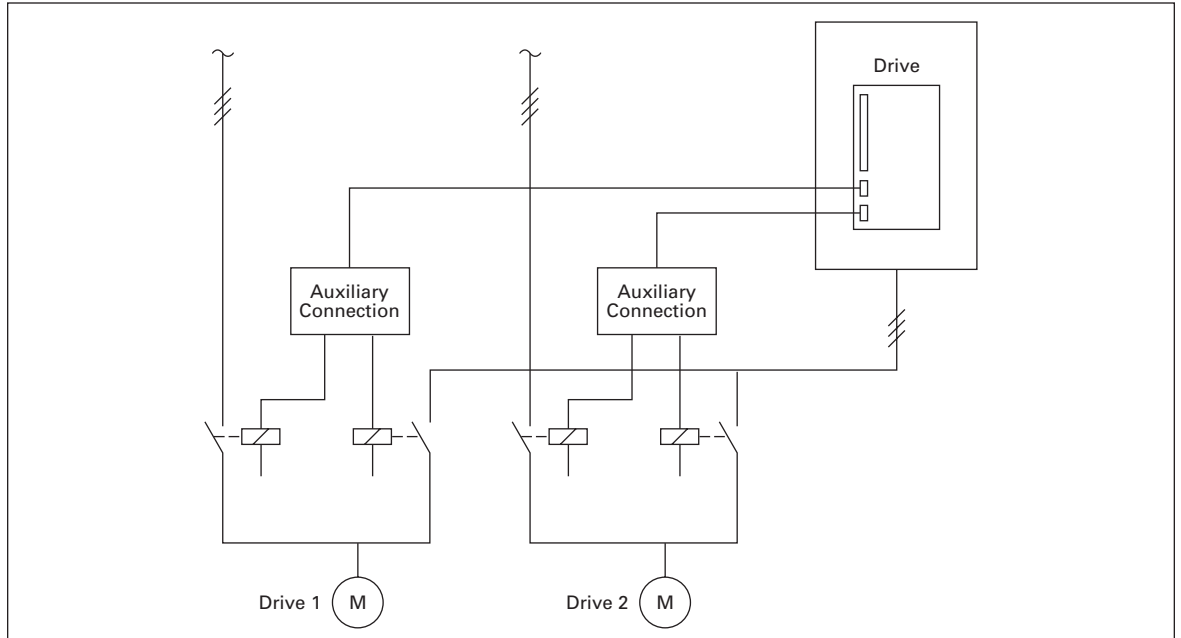

Figure 9-35: Autochange with All Drives

3 Autochange and interlocks (only auxiliary pumps)

The drive controlled by the drive is included in the automatics and a contactor is needed for each drive to connect it to either the mains or the drive.

4 Autochange and interlocks (Drive and aux pumps)

The drive controlled by the drive is included in the automatics and a contactor is needed for each drive to connect it to either the mains or the drive. DIN 1 is automatically interlocked for Autochange output 1. Interlocks for Autochange output 1, 2, 3 (or DIE1, 2, 3) can be selected with par. 2.1.17 and 2.1.18.

2.10.5 Autochange interval ID1029

After the time defined with this parameter, the autochange function takes place if the capacity used lies below the level defined with parameters 2.10.7 (Autochange frequency limit) and 2.10.6 (Maximum number of auxiliary drives). Should the capacity exceed the value of P2.10.7, the autochange will not take place before the capacity goes below this limit.

- The time count is activated only if the Start/Stop request is active. The time count is reset after the autochange has taken place or on removal of Start request.
- The time count is reset after the autochange has taken place or on removal of Start request.

2.10.6 Maximum number of auxiliary drives ID1030**2.10.7 Autochange frequency limit** ID1031

These parameters define the level below which the capacity used must remain so that the autochange can take place.

This level is defined as follows:

- If the number of running auxiliary drives is smaller than the value of parameter 2.10.6, the autochange function can take place.
- If the number of running auxiliary drives is equal to the value of parameter 2.10.6 and the frequency of the controlled drive is below the value of parameter 2.10.7, the autochange can take place.
- If the value of parameter 2.10.7 is 0.0 Hz, the autochange can take place only in rest position (Stop and Sleep) regardless of the value of parameter 2.10.6.

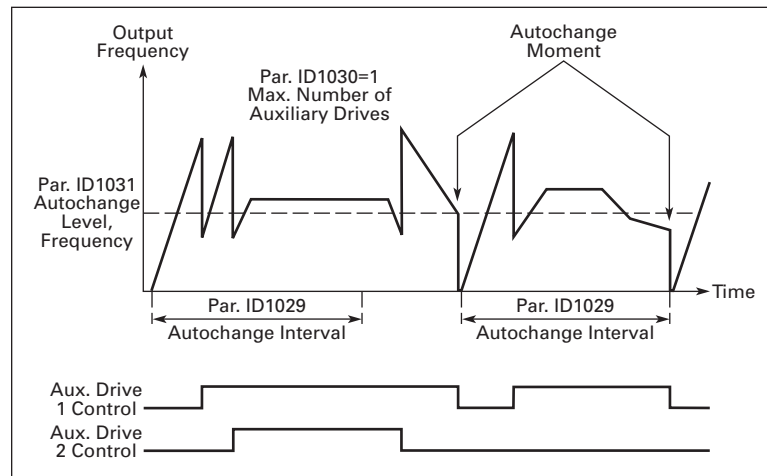

Figure 9-36: Autochange Interval and Limits

2.10.8 Start frequency, auxiliary drive 1 ID1002

The frequency of the drive controlled by the drive must exceed the limit defined with these parameters with 1 Hz before the auxiliary drive is started. The 1 Hz overdraft makes a hysteresis to avoid unnecessary starts and stops. See also parameters 2.1.1 and 2.1.2.

October 2007

2.10.9 Stop frequency, auxiliary drive 1 ID1003

The frequency of the drive controlled by the drive must fall with 1Hz below the limit defined with these parameters before the auxiliary drive is stopped. The stop frequency limit also defines the frequency to which the frequency of the drive controlled by the drive is dropped after starting the auxiliary drive.

Keypad Control Parameters**P3.1 Control place**

The active control place can be changed with this parameter. For more information, see **Page 5-10**.

R3.2 Keypad reference

The frequency reference can be adjusted from the keypad with this parameter. For more information, see **Page 5-11**.

P3.3 Keypad direction

This parameter allows you to invert the error value of the PID controller (and thus the operation of the PID controller).

0 Forward: The rotation of the motor is forward, when the keypad is the active control place.

1 Reverse: The rotation of the motor is reversed, when the keypad is the active control place.

For more information, see **Page 5-11**.

R3.4 Stop button activated

If you wish to make the Stop button a “hotspot” which always stops the drive regardless of the selected control place, give this parameter the value 1 (default). See **Page 5-11**.

See also parameter 3.1.

R3.5 PID reference 1

The PID controller keypad reference can be set between 0% and 100%. This reference value is the active PID reference if parameter 2.9.2 = 2.

R3.6 PID reference 2

The PID controller keypad reference 2 can be set between 0% and 100%. This reference is active if the DIN# function=12 and the DIN# contact is closed.

October 2007

Appendix A — Fault Codes

When a fault is detected by the drive’s control electronics, the drive is stopped and the symbol F together with the ordinal number of the fault, the fault code and a short fault description appear on the display. The fault can be reset with the RESET button on the control keypad or via the I/O terminal. The faults are stored in the Fault History Menu M5, which can be browsed. **Table A-1** contains all the fault codes.

Table A-1: Fault Codes

Fault Code	Fault	Possible Cause	Solution
1	Overcurrent	Drive has detected too high a current (>4xI _n) in the motor cable: <ul style="list-style-type: none"> • sudden heavy load increase • short circuit in motor cables • unsuitable motor 	Check loading. Check motor. Check cables.
2	Overvoltage	The DC-link voltage has exceeded the limits defined in Table 1-8 : <ul style="list-style-type: none"> • too short a deceleration time • high overvoltage spikes in supply 	Set the deceleration time longer.
3	Ground Fault ^①	Current measurement has detected that the sum of motor phase currents is not zero. <ul style="list-style-type: none"> • insulation failure in cables or motor 	Check motor cable and motor.
5	Charging Switch	The charging switch was open when the START command was been given due to: <ul style="list-style-type: none"> • faulty operation • component failure 	Reset the fault and restart. Should the fault re-occur, contact your Cutler-Hammer distributor.
6	Emergency stop	An Emergency stop signal was received from one of the digital inputs	Determine the reason for the Emergency stop and remedy it.
7	Saturation trip	<ul style="list-style-type: none"> • defective component • motor or motor cable short 	Cannot be reset from the keypad. Switch off power. If this fault appears simultaneously with Fault 1, check the motor and motor cables. IF THE PROBLEM IS NOT IN THE MOTOR OR ITS CABLES, DO NOT RE-CONNECT POWER! Contact your Cutler-Hammer distributor.
8	System fault	<ul style="list-style-type: none"> • component failure • faulty operation 	Reset the fault and restart. Should the fault reoccur, contact your Cutler-Hammer distributor.

^① Programmable.

Table A-1: Fault Codes (Continued)

Fault Code	Fault	Possible Cause	Solution
9	Undervoltage ^①	DC-link voltage is under the voltage limits defined in <ul style="list-style-type: none"> • most probable cause: too low a supply voltage • drive internal fault 	In case of temporary supply voltage break, reset the fault and restart the drive. Check the supply voltage. If it is adequate, an internal failure has occurred. Contact your Cutler-Hammer distributor.
10 ^①	Input line supervision	Input line phase is low or missing.	Check the utility supply voltage, cables and connections.
11	Output phase supervision ^①	Current measurement has detected that there is no current in one motor phase.	Check motor cable and motor.
13	Drive undertemperature	Heatsink temperature is under -10°C.	Provide supplemental heating, or relocate drive.
14	Drive overtemperature	Heatsink temperature is over 90°C. Overtemperature warning is issued when the heatsink temperature exceeds 85°C.	Check the correct amount and flow of cooling air. Check the heatsink for dust. Check the ambient temperature. Make sure that the switching frequency is not too high in relation to ambient temperature and motor load.
15	Motor stalled ^①	Motor stall protection has tripped.	Check motor.
16	Motor overtemperature ^①	<ul style="list-style-type: none"> • motor overheating has been detected by drive motor temperature model • motor is overloaded 	Decrease the motor load. If no motor overload exists, check the temperature model parameters.
17	Motor underload ^①	Motor underload protection has tripped.	
22	EEPROM checksum fault	Parameter save fault <ul style="list-style-type: none"> • faulty operation • component failure 	Contact your Cutler-Hammer distributor.
24	Counter fault ^②	Values displayed on counters are incorrect.	
25	Microprocessor watchdog fault	<ul style="list-style-type: none"> • faulty operation • component failure 	Reset the fault and restart. Should the fault re-occur, contact your Cutler-Hammer distributor.
29	Thermistor fault ^①	The thermistor input of option board has detected increase of the motor temperature.	Check motor cooling and loading. Check thermistor connection. (If thermistor input of the option board is not in use, it has to be short circuited.)
32	Fan cooling	The cooling fan did not start when commanded	Contact your Cutler-Hammer distributor.
34	Internal bus communication	Ambient interference or defective hardware	Should the fault re-occur, contact your Cutler-Hammer distributor.
35	Application fault	Selected application does not function	Contact your Cutler-Hammer distributor.

^① Programmable.

^② "A" faults only.

October 2007

Table A-1: Fault Codes (Continued)

Fault Code	Fault	Possible Cause	Solution
39	Device removed ^②	<ul style="list-style-type: none"> option board removed drive removed 	Reset
40	Device unknown	Unknown option board or drive.	Contact your Cutler-Hammer distributor.
41	IGBT temperature	IGBT Inverter Bridge overtemperature protection has detected too high a motor current.	Check loading. Check motor size.
44	Device change ^②	<ul style="list-style-type: none"> option board changed option board has default settings 	Reset.
45	Device added ^②	<ul style="list-style-type: none"> option board changed option board has default settings 	Reset.
50	Analog input $I_{in} < 4$ mA (selected signal range 4 to 20 mA) ^①	Current at the analog input is < 4 mA. <ul style="list-style-type: none"> control cable is broken or loose signal source has failed. 	Check the current loop circuitry.
51	External fault	Digital input failed. Digital input has been programmed as external fault input and this input is active.	Check the programming and the device indicated by the external fault information. Check also the cabling of this device.
52	Keypad communication fault	The connection between the control keypad and the drive is broken.	Check the keypad connection and keypad cable.
53	Fieldbus fault ^①	The data connection between the fieldbus master and the fieldbus board is broken.	Check installation. If installation is correct contact your Cutler-Hammer distributor.
54	Slot fault ^①	Defective option board or slot.	Check that the board is properly installed and seated in slot. If the installation is correct, contact your Cutler-Hammer distributor.
55	Actual value supervision ^①	Actual value has exceeded or fallen below (depending on para. 2.7.22) the actual value supervision limit (para. 2.7.23)	

^① Programmable.

^② "A" faults only.

October 2007

Appendix B — Expander Board OPTAA

Description of Expander Board OPTAA

- Description:** I/O expander board with one relay output, one open collector output and three digital inputs.
- Allowed slots:** SLX9000 board slot E
- Type ID:** 16705
- Terminals:** Two terminal blocks; screw terminals (M2.6 and M3); no coding
- Jumpers:** None
- Board parameters:** None

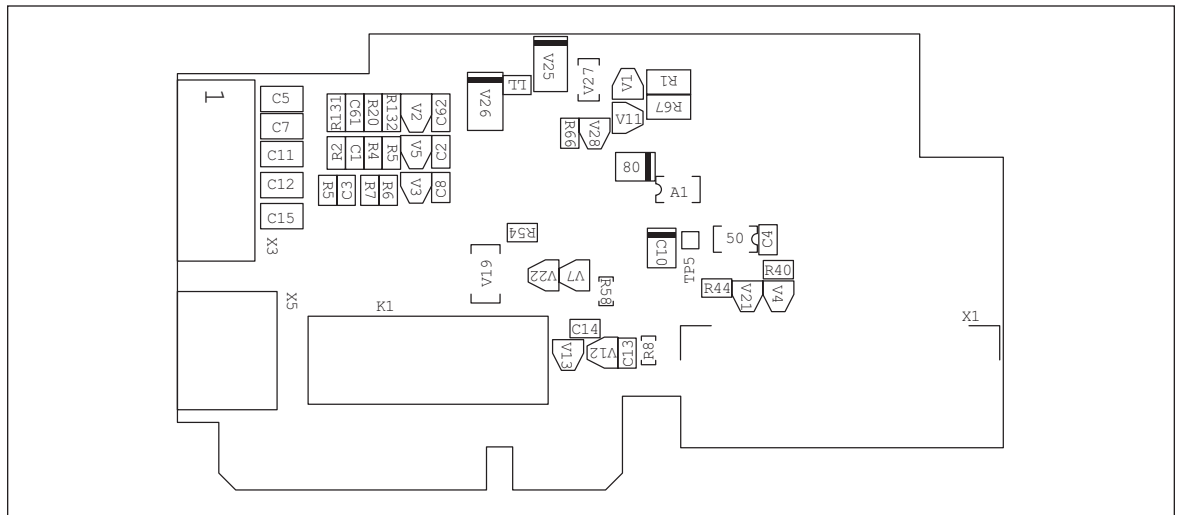

Figure B-1: Expander Board OPTAA

I/O Terminals on OPTAA

Table B-1: I/O Terminals of Board OPTAA

Terminal	Parameter Setting	Description	
X3			
1	+24V	Control voltage output; voltage for switches etc., max. 150 mA	
2	GND	Ground for controls, e.g. for +24V and DO	
3	DIN1	DIGIN:x.1	Digital input 1
4	DIN2	DIGIN:x.2	Digital input 2
5	DIN3	DIGIN:x.3	Digital input 3
6	DO1	DIOUT:x.1	Open collector output, 50 mA/48V
X5			
24	RO1/NC	DIOUT:x.2	Relay output 1 (NO) Switching capacity: 24V DC/8A 250V AC/8A 125V DC/.4A
25	RO1/C		
26	RO1/NO		

Note: The +24V control voltage terminal can also be used to power the control module (but not the power module).

October 2007

Appendix C — Expander Board OPTAI

Description of Expander Board OPTAI



- Description:** I/O expander board with one relay output (NO), three digital inputs and one thermistor input for SLX9000 drives.
- Allowed slots:** SLX9000 board slot E
- Type ID:** 16713
- Terminals:** Two terminal blocks; screw terminals; no coding
- Jumpers:** None
- Board parameters:** None



Figure C-1: Expander Board OPTAI

I/O Terminals on OPTAI

Table C-1: I/O Terminals of Board OPTAI

Terminal	Parameter Setting	Description	
X4			
12	+24V	Control voltage output; voltage for switches etc., max. 150 mA	
13	GND	Ground for controls, e.g. for +24V and DO	
14	DIN1	DIGIN:B.1	Digital input 1
15	DIN2	DIGIN:B.2	Digital input 2
16	DIN3	DIGIN:B.3	Digital input 3
X2			
24	RO1/ Common	DIOUT:B.1  Relay output 1 (NO) Switching capacity: 24V DC/8A 250V AC/8A 125V DC/.4A	
25	RO1/Normal Open		
X3			
28	TI+	DIGIN:B.4	Thermistor input; Rtrip = 4.7 kΩ (PTC)
29	TI-		

Note: The +24V control voltage terminal can also be used to power the control module (but not the power module).

October 2007

Appendix D — Option Board Kits

230V, FR7 – FR8 460V and 575V Drives

The factory installed standard board configuration includes an A9 I/O board and an A2 relay output board, which are installed in slots A and B.

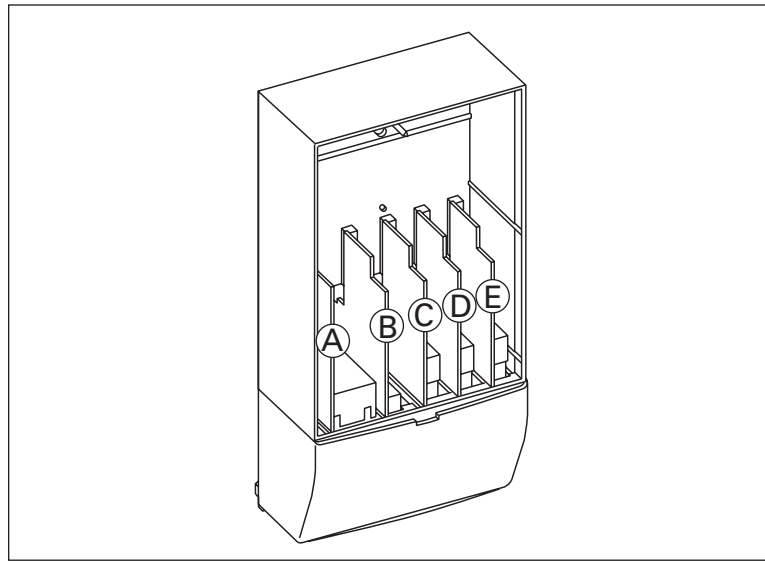

Figure D-1: Option Boards

Table D-1: Option Board Kits

Option Kit Description ^②	Allowed Slot Locations ^①	Field Installed	Factory Installed	9000X Ready Programs						
		Catalog Number	Option Designator	Basic	Local/Remote	Standard	MSS	PID	Multi-P.	PFC
Standard I/O Cards (See Figure D-1)										
2 RO (NC/NO)	B	OPTA2	—	X	X	X	X	X	X	X
6 DI, 1 DO, 2 AI, 1 AO, 1 +10V DC ref, 2 ext +24V DC/EXT +24V DC	A	OPTA9	—	X	X	X	X	X	X	X
Extended I/O Card Options										
2 RO, Therm	B	OPTA3	A3	—	X	X	X	X	X	X
Encoder low volt +5V/15V/24V	C	OPTA4	A4	—	X	X	X	X	X	X
Encoder high volt +15V/24V	C	OPTA5	A5	—	X	X	X	X	X	X
Double encoder — SPX Only	C	OPTA7	A7	X	X	X	X	X	X	X
6 DI, 1 DO, 2 AI, 1 AO	A	OPTA8	A8	—	X	X	X	X	X	X
3 DI (Encoder 10 – 24V), Out +15V/+24V, 2 DO (pulse+direction) — SPX Only	C	OPTAE	AE	X	X	X	X	X	X	X

^① Option card must be installed in one of the slots listed for that card. Slot indicated in Bold is the preferred location.

^② AI = Analog Input; AO = Analog Output, DI = Digital Input, DO = Digital Output, RO = Relay Output

Table D-1: Option Board Kits (Continued)

Option Kit Description ^②	Allowed Slot Locations ^①	Field Installed	Factory Installed	9000X Ready Programs						
		Catalog Number	Option Designator	Basic	Local/Remote	Standard	MSS	PID	Multi-P.	PFC
Extended I/O Card Options (Continued)										
6 DI, 1 ext +24V DC/EXT +24V DC	B, C, D , E	OPTB1	B1	—	—	—	—	—	X	X
1 RO (NC/NO), 1 RO (NO), 1 Therm	B, C, D , E	OPTB2	B2	—	—	—	—	—	X	X
1 AI (mA isolated), 2 AO (mA isolated), 1 ext +24V DC/EXT +24V DC	B, C, D , E	OPTB4	B4	—	X	X	X	X	X	X
3 RO (NO)	B, C, D , E	OPTB5	B5	—	—	—	—	—	X	X
1 ext +24V DC/EXT +24V DC, 3 Pt100	B, C, D , E	OPTB8	B8	—	—	—	—	—	—	—
1 RO (NO), 5 DI 42 – 240V AC Input	B,C, D , E	OPTB9	B9	—	—	—	—	—	X	X
SPI, Absolute Encoder	C	OPTBB	BB	—	—	—	—	—	—	—

^① Option card must be installed in one of the slots listed for that card. Slot indicated in Bold is the preferred location.

^② AI = Analog Input; AO = Analog Output, DI = Digital Input, DO = Digital Output, RO = Relay Output

Company Information

Eaton's electrical business is a global leader in electrical control, power distribution, uninterruptible power supply and industrial automation products and services. Eaton's global electrical brands, including Cutler-Hammer®, Powerware®, Holec® and MEM®, provide customer-driven PowerChain Management™ solutions to serve the power system needs of the industrial, institutional, government, utility, commercial, residential, IT, mission critical and OEM markets worldwide.

Eaton Corporation is a diversified industrial manufacturer with 2006 sales of \$12.4 billion. Eaton is a global leader in electrical systems and components for power quality, distribution and control; fluid power systems and services for industrial, mobile and aircraft equipment; intelligent truck drivetrain systems for safety and fuel economy; and automotive engine air management systems, powertrain solutions and specialty controls for performance, fuel economy and safety. Eaton has 62,000 employees and sells products to customers in more than 125 countries. For more information, visit www.eaton.com.

Eaton Corporation
Electrical Group
1000 Cherrington Parkway
Moon Township, PA 15108
United States
877-ETN CARE (877-386-2273)
Eaton.com

EAT•N

Cutler-Hammer

© 2007 Eaton Corporation
All Rights Reserved
Printed in USA
Publication No. MN04003020E/CPG
October 2007